

CUSTOMER'S NAME: HONG KONG NOBLE
CARAVELLE

PART NAME: VARIABLE RESISTOR

PART No.:

NOBLE

ELECTRONIC COMPONENTS

SPECIFICATION

This products satisfies RoHS Directive 2002/95/EC

REVISIONS		
LTR	DESCRIPTION	DATE

APPROVAL STATUS	
APPROVED	REJECTED
SIGNATURE	DATE

NOBLE REFERENCE No: 868-9007C(/D)
NOBLE TYPE NAME: TMC3KJ-B□□Ω-TR(/D)

PREPARED BY <i>M. Yoneda</i>	DATE 21/Apr/2008
REVIEWED BY	
APPROVED BY <i>K. Yanoshita</i>	21/Apr/2008
<i>Y. Sasaki</i>	25/APR/2008

Please return one copy of this drawing with your signature of approval and retain the others for your record. In the event of an order being placed for this part number before the signed copy is returned, it will be assumed that full approval have been given.



TEIKOKU TSUSHIN KOGYO CO., LTD.

335, Kariyado, Nakahara-ku, Kawasaki, 221-8530, Japan

Quality Assurance Department

Phone: +81-44-434-2281 Facsimile: +81-44-433-8174

会社(工場)名 CUSTOMER'S NAME	部番(ストックNo.) CUSTOMER'S PART No.
-------------------------	---------------------------------

1. 外形寸法図
EXTERNAL DIMENSIONS

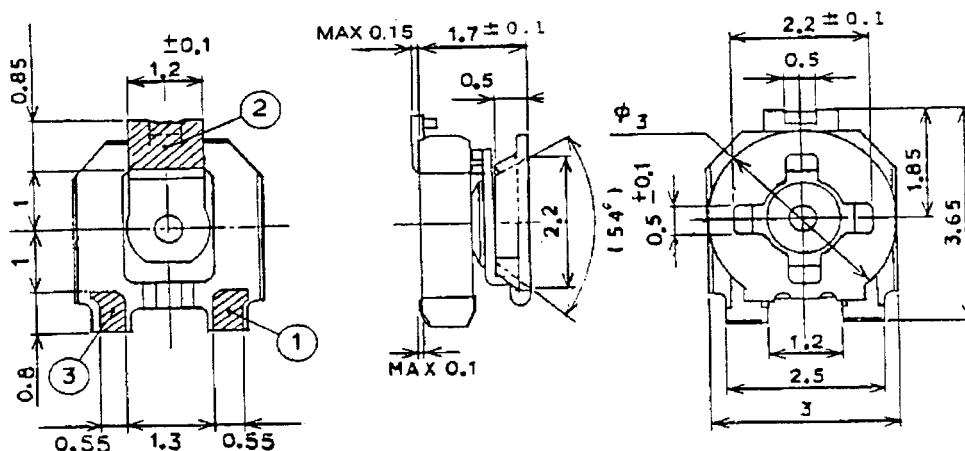

はんだパターン(リフロー用)
(参考寸法)
PATTERN (FOR REFLOW SOLDERING)
(REFERENCE)

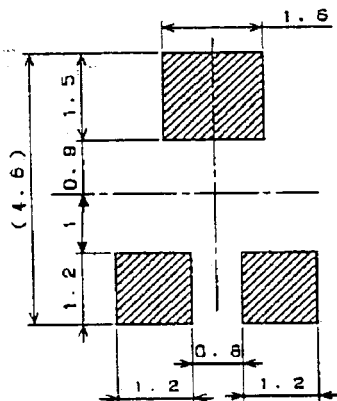

回路図

CIRCUIT DIAGRAM

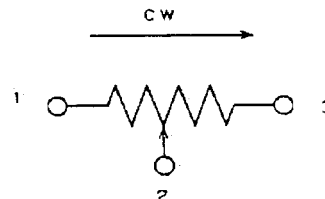

△	△	△	△	△	△	△	△
△	△	△	△	△	△	△	△
△	△	△	△	△	△	△	△
DATE	REVISION	APPROVED	一般公差 TOL. UNLESS OTHERWISE STATED		帝通名 NOBLE PART NAME		
設計 DESIGNED	検図 CHECKED	尺度 SCALE	10	1	TMC3KJ-B□□□Ω-TR(∕D)		
2007.2.21	2007.2.21	10	1	1	帝通図番 DRAWING No.		
単位 UNIT	mm	第三角法 THIRD ANGLE PROJECTION METHOD	300-less than 1000	ANGLE	868-9007C(∕D)		
			±2.0	±5	様式 02A		

2. Scope : This specification is applied to Model TMC3KJ types mainly used for consumer products.

3. Model : TMC3KJ (Automatic adjustable type)

In conjunction with UNIT
The value indicated in { } described
after SI unit's value is a reference.

4. Appearance

- 4.1 Appearance: There shall be no remarkable damage in the visual inspection.
- 4.2 Dimension: Please see the drawing attached.

5. Test Conditions

In this specification standard temperature and atmospheric pressure are 20°C and 101.3 kPa {1013mbar} respectively. Unless otherwise specified, all tests shall be done in a 15 to 35°C at an atmospheric pressure of 86 to 106kPa {860 to 1060mbar} and a relative humidity 25 to 85%. In case there are any doubtful points in judgement or reproductivity is needed. They shall be in accordance with JIS C 0010 Referee Test Condition Symbol I Grade 2 (issued in 1993).

6. Rating

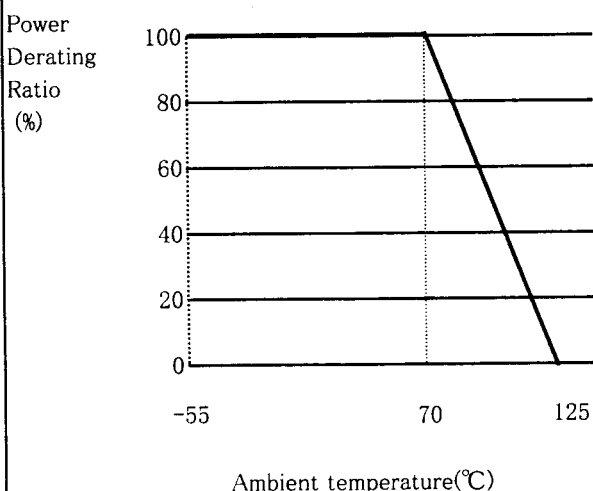
No.	Items	Testing Method and Condition	Specification	
6.1	Operating Temp. Range		-55~+125°C	
6.2	Storage Temp. Range		Para.9.2 Cold Resistance (Storage) and para. 9.9 Resistance to Heat(Storage) shall be satisfied.	
6.3	Rated Power	Rated power shall be based on continuous full load between terminals 1 and 3 at ambient temperature of 70 °C. In case of ambient temperature 70 to 125 °C, The power level shall be derated in accordance with the diagram below. Fig 1 Derating Curve of Rated Power 	Rated power shall comply with the table below.	
			<table border="1" style="width: 100%; border-collapse: collapse;"> <thead> <tr> <th style="width: 50%;">Resistance Taper</th> <th style="width: 50%;">Rated Power (W)</th> </tr> </thead> <tbody> <tr> <td style="text-align: center;">B</td> <td style="text-align: center;">0.1</td> </tr> </tbody> </table>	Resistance Taper
Resistance Taper	Rated Power (W)			
B	0.1			
6.4	Rated Voltage	Rated voltage shall be continuous working voltage of DC or AC (r.m.s. value at power frequency) corresponding to the rated power, and be obtained from the following formula. When the obtained rated voltage exceeds the maximum working voltage of para. 6.5, the maximum working voltage shall be the rated voltage. $E = \sqrt{P \cdot R}$ E:Rated Voltage(V) P:Rated power(W) R:Nominal total resistance(Ω)	Rated voltage shall comply with the left.	
6.5	Max. Rated Voltage		AC 20 V, DC 20 V	

△	.	.	△	.	.		
△	.	.	△	.	.	帝通図番	868-9007C(/D)
△	.	.	△	.	.	DRAWING No.	
DATE	REVISION	APPROVED					

7. Electrical Performance

No.	Items	Testing Method and Condition	Specification						
7.1	Nominal Total Resistance		Nominal total resistance shall comply with the table 1.						
7.2	Total Resistance		Total resistance shall be within $\pm 25\%$ of the nominal total resistance.						
7.3	Resistance Taper		Taper B (Linear)						
7.4	Residual Resistance	<p>The wiper shall be placed at the each end of the effective rotational angle and then the resistance between terminal 1-2 and 2-3 shall be measured.</p> <table border="1"> <thead> <tr> <th>Nominal Total Resistance</th> <th>Residual Resistance</th> </tr> </thead> <tbody> <tr> <td>$R < 300 \Omega$</td> <td>Less than 3Ω</td> </tr> <tr> <td>$R \geq 300 \Omega$</td> <td>Less than 1 % of the nominal total resistance</td> </tr> </tbody> </table>	Nominal Total Resistance	Residual Resistance	$R < 300 \Omega$	Less than 3Ω	$R \geq 300 \Omega$	Less than 1 % of the nominal total resistance	Residual resistance shall comply with the table left.
Nominal Total Resistance	Residual Resistance								
$R < 300 \Omega$	Less than 3Ω								
$R \geq 300 \Omega$	Less than 1 % of the nominal total resistance								
7.5	Concentration and Contact Resistance	<p>The wiper shall be placed at the point so that the resistance between terminal 1-2 is almost 1/2 of the total resistance.</p> <p>The concentration and contact resistance shall be calculated by the following formula.</p> $\frac{(R_{12}+R_{23})-R_{13}}{2 \times R_{13}} \times 100(\%)$ <p>R 12 : Resistance between terminals 1-2(Ω) R 23 : Resistance between terminals 2-3(Ω) R 13 : Resistance between terminals 1-3(Ω)</p>	Within $\pm 5 \%$.						
7.6	Rotational Noise	<p>The specimen shall be connected to the measuring circuit shown below. The operating knob shall be rotated through 10~90 % of the effective rotational angle at a rate of 6 cycles per minute (one cycle is one turn clockwise, then one turn counter clockwise.)</p> $\text{Rotational noise} : \frac{EPN \times 100}{I \times RN} (\%)$ <p>one turn clockwise, then one turn counter clockwise.)</p> $\text{Rotational noise} : \frac{EPN \times 100}{I \times RN} (\%)$ <p>EPN : Maximum deviation limit on the oscilloscope (V) I : Measuring current (A) RN : Nominal total resistance of the specimen (Ω)</p> <p>Rx; unit on test</p> <p>Input impedance of the oscilloscope must be more than 10 times as much as of the nominal total resistance of the specimen and measuring current must not exceed the rated current.</p>	Within $\pm 5 \%$.						

△	.	.		△	.	.	
△	.	.		△	.	.	
△	.	.		帝通図番			
	DATE	REVISION	APPROVED	DRAWING No.	868-9007C(/ D)		

No.	Items	Testing Method and Condition	Specification								
7.7	Resistance Temperature Characteristic	Total resistance after being exposed in a test chamber at a specified table below for 30 minutes shall be measured. Temperature at order 2 shall be considered as the reference temperature when calculating temperature coefficient. <table border="1" style="margin-left: 20px;"> <thead> <tr> <th>Order</th> <th>Temperature °C</th> </tr> </thead> <tbody> <tr> <td>1</td> <td>-55±3°C</td> </tr> <tr> <td>2</td> <td>20±2°C</td> </tr> <tr> <td>3</td> <td>125±3°C</td> </tr> </tbody> </table> Temperature coefficient (ppm/°C) $= \frac{(R-R_0) \times 1000000}{R_0 \times (t-t_0)}$ Where R : Total resistance at t (order 1 or 3) °C (Ω) R0 : Total resistance at t0 (order 2) °C (Ω) t : Temperature at t (order 1 or 3)°C t0 : Temperature at t0 (order 2)°C	Order	Temperature °C	1	-55±3°C	2	20±2°C	3	125±3°C	Within ±250 ppm/°C.
Order	Temperature °C										
1	-55±3°C										
2	20±2°C										
3	125±3°C										

8. Mechanical Performance

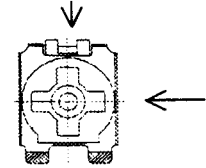
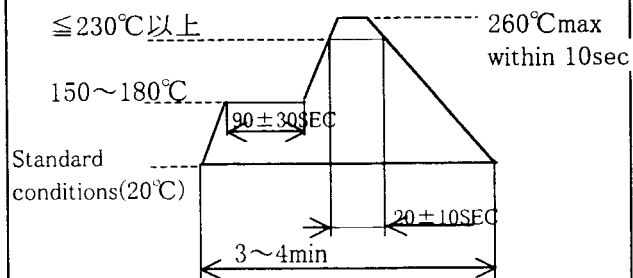
No.	Items	Testing Method and Condition	Specification
8.1	Total Rotational angle	Endless (effective rotational angle)	250±20°
8.2	Rotational Torque	Rotational torque shall be measured according to JIS C 5261 (issued in 1993) para/6.2.	1~20 mN·m {10.2~204.1 gf·cm}
8.3	Resistance to Vibration	The wiper shall be placed at the point so that the resistance between terminal 1-2 is almost 1/2 of the total resistance, and 2 hours of vibration specified below shall be applied in each of three mutually perpendicular directions for a total of 6 hours. (In accordance with JIS C 0040 issued in 1995) 1 cycle : 10 Hz→55 Hz→10 Hz being swept linearly over 1 minute Amplitude : 1.5 mm sine wave	Variation rate of total resistance shall be within ±2 %.
8.4	Robustness of Electrode	The specimen shall be soldered in a same manner as para. 8.5, and then the static load 5 N (510 gf) shall be applied to the side of resistance element as shown in figure below. The soldering electrode pattern on circuit board is shown in 2/12 page. 	There shall not be abnormality such as voids, breaks and cracks of soldering portions. Para. 7.4 Residual Resistance, para. 7.5 Concentration and Contact Resistance, para. 7.6 Rotational Noise and para. 8.2 Rotational Torque shall be satisfied.
8.5	Resistance to Reflow Soldering Heat	Resistance to reflow soldering heat shall be measured according to the figure next page. (Temperature shows the maximum value at the soldering portions of terminals.) 	Variation rate of total resistance shall be within ±2 %.

△	.	.		△	.	.	
△	.	.		△	.	.	
△	.	.		帝通図番			
	DATE	REVISION	APPROVED	DRAWING No.		868-9007C(/D)	

No.	Items	Testing Method and Condition	Specification
8.6	Shock	The wiper shall be placed at the point so that the resistance between terminal 1-2 is almost 1/2 of the total resistance, and maximum acceleration 490 m/s ² (50 G); half-sine pulse waveform with duration 11 ms shall be applied in each of 6 mutually perpendicular directions, 3 times for a total of 18, according to JIS C 5261 (issued in 1993) para. 6.7.	Variation rate of total resistance shall be within ±2 %.

9. Environmental and Endurance Characteristics

No.	Items	Testing Method and Condition	Specification															
9.1	Resistance to Cold	The specimen shall be subjected in a test chamber at -55±3°C at no load for 48±4 hours, and then left to the standard conditions for 1 to 2 hours.	Variation rate of total resistance shall be within ±5 %.															
9.2	Resistance to Cold (Storage)	The specimens shall be packed in the minimum packing unit designated and subjected in a test chamber at -5±3°C for 72±2 hours, and then left to the standard conditions for 1 to 2 hours.	Variation rate of total resistance shall be within ±5 %. para. 7.6 Rotational noise, para. 8.2 Rotational Torque and para. 8.5. Resistance to Reflow Soldering Heat shall be satisfied.															
9.3	Temperature Cycle	The specimen shall be maintained at each temperature and duration specified in a table below for continuous 5 cycles, and then left to the standard conditions for 1 to 2 hours.	Variation rate of total resistance shall be within ±2 %.															
		<table border="1"> <thead> <tr> <th>Order</th> <th>Temperature°C</th> <th>Time (minutes)</th> </tr> </thead> <tbody> <tr> <td>1</td> <td>-55±3</td> <td>30~35</td> </tr> <tr> <td>2</td> <td>Std. Condition</td> <td>10~15</td> </tr> <tr> <td>3</td> <td>125±3</td> <td>30~35</td> </tr> <tr> <td>4</td> <td>Std. Condition</td> <td>10~15</td> </tr> </tbody> </table>		Order	Temperature°C	Time (minutes)	1	-55±3	30~35	2	Std. Condition	10~15	3	125±3	30~35	4	Std. Condition	10~15
		Order		Temperature°C	Time (minutes)													
		1		-55±3	30~35													
		2		Std. Condition	10~15													
3	125±3	30~35																
4	Std. Condition	10~15																
9.4	Resistance to Damp (Steady State)	The specimen shall be subjected in a test chamber at 40±2°C, 90~95% RH at no load for 240±8 hours, and then left to the standard conditions for 1 to 2 hours.	Variation rate of total resistance shall be within ±5 %.															
9.5	Endurance (Damp Resistant Loading)	The specimen shall be subjected in a test chamber at 40±2°C, 90~95% RH with a rated DC voltage applied across terminals 1-3 for 1,000±12 hours at a cycle consisting of an "ON" time 1.5 hours and an "OFF" time 0.5 hours, under the condition that the wiper shall be at the point so that the resistance between terminal 1-2 is almost 1/2 of the total resistance, and then left to the standard conditions for 1 to 2 hours.	Variation rate of total resistance shall be within ±5 %.															
9.6	Endurance (Rated Load)	The specimen shall be subjected in a test chamber at 70±3°C, with a rated DC voltage applied across terminals 1-3 for 1,000±12 hours at a cycle consisting of an "ON" time 1.5 hours and an "OFF" time 0.5 hours, under the condition that the wiper shall be at the point so that the resistance between terminal 1-2 is almost 1/2 of the total resistance, and then left to the standard conditions for 1 to 2 hours.	Variation rate of total resistance shall be within ±3 %.															
9.7	Endurance (Sliding)	The wiper shall be rotated for 20 cycles (one cycle is one turn clockwise, then one turn counter clockwise), at a rate of 10~17 cycles per minute, according to JIS C5261 (issued in 1993) para. 7.8. In case nominal total resistance is less than 200 Ω, the operating life is 10 cycles.	Variation rate of total resistance shall be within ±10%.															

△	.	.		△	.	.	
△	.	.		△	.	.	
△	.	.					
	DATE	REVISION	APPROVED	帝通函番 DRAWING No.		868-9007C(/D)	

No.	Items	Testing Method and Condition	Specification
9.8	Resistance to Heat	The specimen shall be subjected in a test chamber at $125 \pm 3^\circ\text{C}$ at no load for 240 ± 2 hours. Under the condition that the wiper shall be at the point so that the resistance between terminal 1-2 is almost 1/2 of the total resistance, and then left to the standard conditions for 1 to 2 hours.	Variation rate of total resistance shall be within $\pm 3\%$. Concentration and contact resistance is within 5% before test and within 10% after test.
9.9	Resistance to Heat (Storage)	The specimens shall be packed in the minimum packing unit designated and subjected in a test chamber at $40 \pm 2^\circ\text{C}$ for 72 ± 2 hours, and then left to the standard conditions for 1 to 2 hours.	Variation rate of total resistance shall be within $\pm 3\%$. para. 7.6 Rotational noise, para. 8.2 Rotational Torque and para 8.5. Resistance to Reflow Soldering Heat shall be satisfied.

10. Notice on usage

10.1 Storage under being packed

- After being received, the products packed shall be stored under 85% max. RH at 5 to 35°C , but not in the place where dew and/or harmful gas are apt to occur.
- Please use the products within 3 months after the receipt.

10.2 Operating temperature range

At a range of -55 to 125°C , the product shall be able to be operated electrically and mechanically.

10.3 In case of soldering by a solder iron, it shall be finished within 5 seconds and the temperature of the tip of the soldering iron shall be 350°C max.

10.4 Flux Rinsing

After reflow-soldering operation, part may be used without rinsing, if flux is well controlled. In case flux rinsing is done, flux shall be removed sufficiently.

10.5 In case of adjustment of unit by driver, the push static force shall be less than 5 N (510 gf)

11. Others

11.1 Recommendable shape of the driver tip shall be shown as figure below (Please use as hard material as possible.)

Recommendable shape (unit : mm)
For automatic adjustment

For hand-operated adjustment

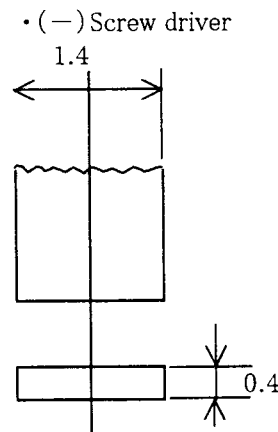
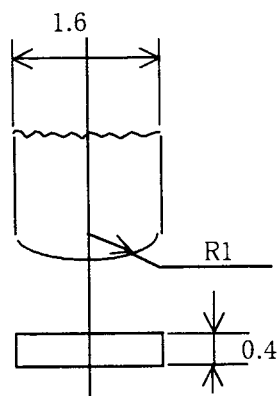

• (-) Screw driver

• (+) Screw driver

Vessel: NO.9000

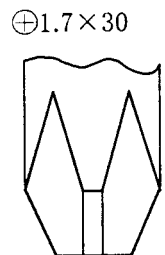

11.2 Country of Origin

•Part name

•Drawing

TMC3KJ-B□□□-TR (JAPAN) 868-9007C 868-1017C

TMC3KJ-B□□□-TR/D (CHINA) 868-9007C/D 868-1017C/D (/D...CHINA)

△	.	.		△	.	.	
△	.	.		△	.	.	
△	.	.		帝通函番		868-9007C(/D)	
	DATE	REVISION	APPROVED	DRAWING No.			

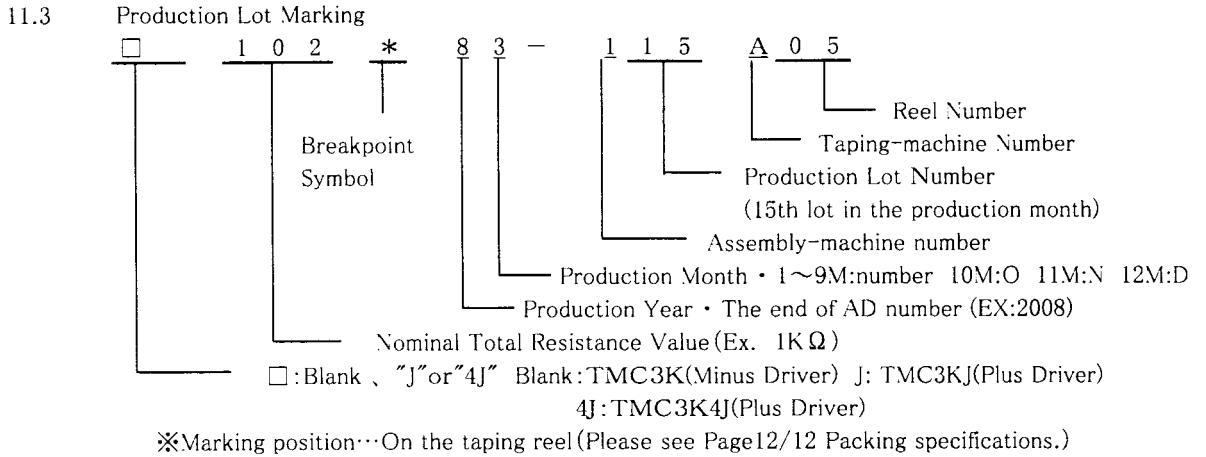

12. Tape packing

12.1 Appearance

- 12.1.1 Appearance: There shall be no remarkable damage in the visual inspection.
- 12.1.2 Dimension: Please see the figure 2.
- 12.1.3 Marking: The following information shall be clearly marked on the surface of the reel with a durable method.
 - (1) Manufacturer's name or Logo (2) Model name of the product
 - (3) Nominal total resistance (4) Production lot code (5) Quantity
 - (6) Customer's part No.

12.2 Packing method

- 1) The tape shall be wound clockwise (The feed holes shall be located at the right side of the tape, when its end is pulled out under the condition that the cover tape is at the upper side of the carrier tape).
- 2) The cover tape shall neither cover the feed holes by more than 0.5 mm nor stick out of the carrier tape.
- 3) The length of the leading portion at the outer end of the tape shall be more than 200 mm and the blank carrier tape of more than 40 mm. (Fig.3)
- 4) The blank carrier tape of more than 40 mm shall be provided at the inner end of the tape near the core of the reel (Fig.3), and it shall be also covered by a cover tape.
- 5) The outer end of the leading portion of the cover tape shall be attached to the reel by an adhesive tape (80~120 mm).
- 6) Force to peel the cover tape off :
The cover tape shall be peeled off at a range of force 0.1~0.7 N (10.2~71.4 gf) when being pulled at an angle of 155~180° shown in Fig.4 and at a speed of 300 mm/min.
- 7) The direction of the products shall be constant (Fig.3).
- 8) 2,000 pcs of the products shall be packed in a reel without any fraction.

12.3 Minimum bending-radius of tape packing

- 1) The minimum bending-radius of the tape packing shall be 30 mm, and when being bent along with a φ60 mm stick for 10±1 seconds, the cover tape shall not be peeled off and no products shall come off.
This maximum bending shall be limited as only one time regardless of the side of the tape.
- 2) The cavities don't touch each other when the carrier tape is bent at R30 mm.

△	.	.			△	.	.		
△	.	.			△	.	.		
△	.	.			帝通図番		868-9007C(∕D)		
	DATE	REVISION	APPROVED		DRAWING No.				

EIAJ規格品 (参考寸法)
リール寸法
FIG.2 REEL DIMENSION

FIG.4

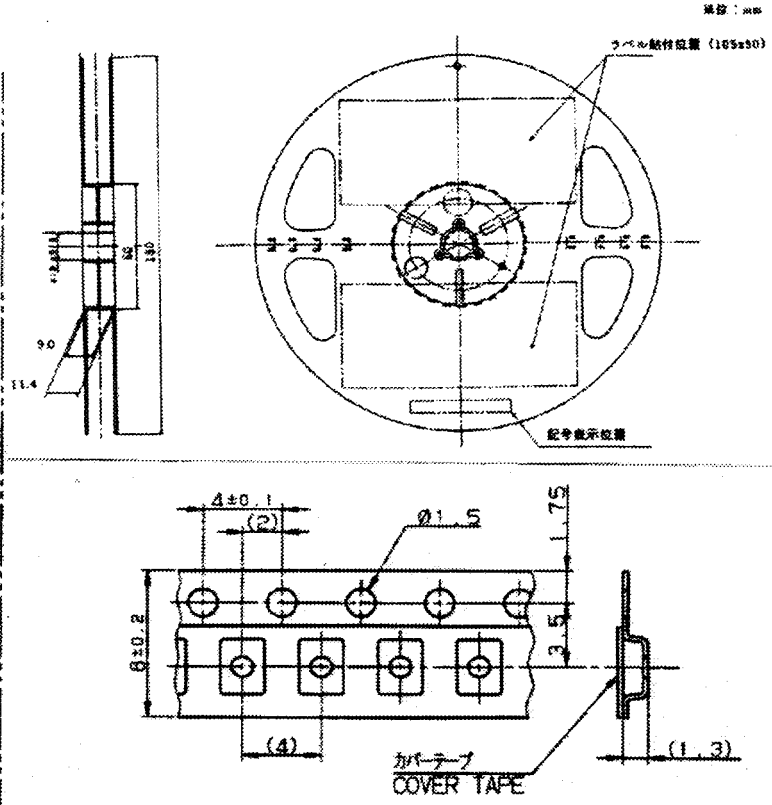
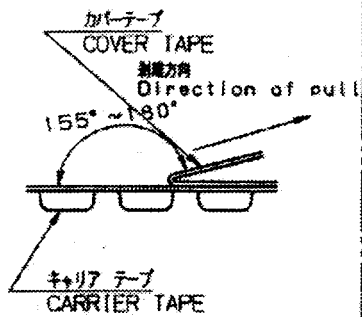
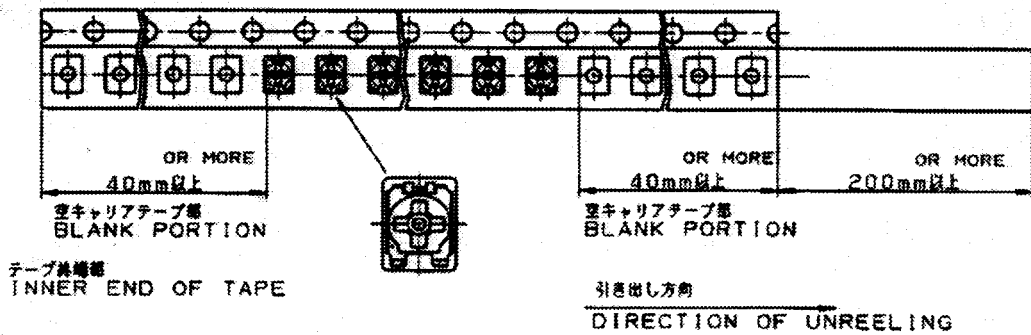

FIG.3
EIAJ規格準拠



△	.	.		△	.	.	
△	.	.		△	.	.	
△	.	.		帝通図番		868-9007C(/ D)	
	DATE	REVISION	APPROVED	DRAWING No.			

表1 抵抗変化特性と公称全抵抗値表
RESISTANCE TAPER & NOMINAL TOTAL RESISTANCE
(E3シリーズ)

帝通図番 DRAWING No.	抵抗変化特性 Resistancs Taper	公称全抵抗値(Ω) Nominal Total Resis Tance
868-9007C-1(/D)	B (0B)	100
868-9007C-4(/D)	B (0B)	220
868-9007C-7(/D)	B (0B)	470
868-9007C-10(/D)	B (0B)	1K
868-9007C-13(/D)	B (0B)	2.2K
868-9007C-16(/D)	B (0B)	4.7K
868-9007C-19(/D)	B (0B)	10K
868-9007C-22(/D)	B (0B)	22K
868-9007C-25(/D)	B (0B)	47K
868-9007C-28(/D)	B (0B)	100K
868-9007C-31(/D)	B (0B)	220K
868-9007C-34(/D)	B (0B)	470K
868-9007C-37(/D)	B (0B)	1M
868-9007C-40(/D)	B (0B)	2.2M

注1. 表以外の公称抵抗値は、特殊品(非標準)となり、表2に記載の帝通図番となります。

Note 1. Other nominal resistanc than table 1 are a special order, and the drawingNo. shall be shown in table 2.

注2. 帝通図番の区分は、下記となります。

Note 2. Classification of drowing No. shall be shown in below.

868-□□□□-□□(/D)



9:表1に記載の標準品, 1:非標準品

9:Standard type shown in table 1, 1:Special order

△	.	.		△	.	.	
△	.	.		△	.	.	
△	.	.		帝通図番		868-9007C(/D)	
	DATE	REVISION	APPROVED	DRAWING No.			

表2 納入該当品リスト
Table 2 An Order List

帝通図番 Drawing No	部番(ストックNo) Customer's No	抵抗値変化特性 Resistance Taper	公称抵抗値 Nominal Total Resistance(Ω)	
868-1017C-23(/D)		B	30K	

△	.	.		△	.	.	
△	.	.		△	.	.	
△	.	.		帝通図番 DRAWING No.		868-9007C(/D)	
	DATE	REVISION	APPROVED				

包装仕様
Packing Specification

[1] 包装荷姿 (製品名:TMC3KJ TR)
Package (for:TMC3KJ TR)

- 1. 個装 : 1リール 2,000個詰める。
Package for each piece : Bulk pack, 2,000pcs in 1 reel.
- 2. 内装包装 シングルカートン(リール8個入れ)
Inner Carton Single carton (In 8 Reel)
- 外寸 (単位mm) 180(L) × 180(W) × 95(D)
Outer dimension (mm)
- 最大数 1箱 16,000個 (2,000×8リール)
Maximums 1 Carton=16,000pcs (2,000×8Reel)

3. 外装包装 ダブルカートン
Outer Carton Double carton

外装箱名 Outer Carton	内装箱数 Inner Carton	最大数 Maximums	外寸 Outer dimension (mm)		
			W	L	D
H-1	12箱 (Cartons)	16,000×12 192,000PCS	320	395	415
H-2	8箱 (Cartons)	16,000×8 128,000PCS	320	395	315
H-3	6箱 (Cartons)	16,000×6 96,000PCS	320	395	215
H-4	2箱 (Cartons)	16,000×2 32,000PCS	320	395	150

4. 表示 : 箱の側面に下記内容を表示したラベルを貼ります。
Marking : A packaging label indicating following information shall be attached to the side of the inner cartons.

- ①CUSTOMER (納入先名)
- ②PART NO. (部品No.)
- ③ARRANGED NO. (受注NO.)
- ④QUANTITY (数量)
- ⑤NOBLE NAME (帝通名)

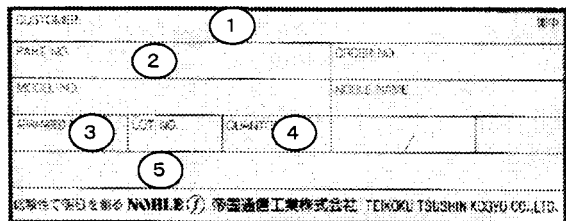

5. 荷姿略図 (リール) (内装) (外装)
Rough sketches (Reel) (Inner carton) (Outer carton)
of each package

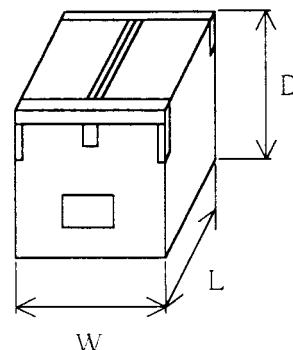
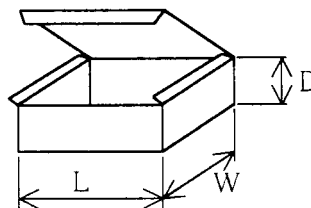
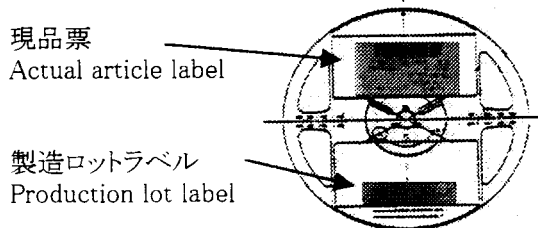

△	・			△	・	
△	・			△	・	
△	・			帝通図番		868-9007C (/ D)
	DATE	REVISION	APPROVED	DRAWING No.		