







	系列 Series	直齒/斜齒 straight/helical	模數 Module	齒面熱處理 heat-treatment of teeth	精度等級 Tolerance of teeth	頁碼 Page
TR-齒輪 Tr pinion EN-ISO	78	直齒 straight	2; 3; 4; 5; 6; 8	表面淬火 case-hardened	5	ZF-1.1-1.5
	24	直齒 straight	2; 3; 4; 5; 6; 8; 10	表面淬火 case-hardened	7 e 25	ZF-2-7
	21/23.. ...	直齒 straight	1; 1,5; 2; 2,5; 3; 4; 5; 6; 8; 10; 12	軟材 soft	8 e 25	ZF-8-15
	06	直齒 straight	1; 1,5; 2; 3	軟材 / 不銹鋼 soft / stainless	8 e 25	ZF-16
	23	直齒 straight	1,5; 2; 2,5; 3; 4; 5; 6	軟材 soft	8 e 26	ZF-8-15
	22	直齒 straight	1; 1,5; 2; 2,5; 3	工程塑料 plastic	9 bc 26	ZF-8-12





ATLANTA

TR系列齒輪連接面符合EN ISO 9409-1-A標準
高精度齒條的最佳選擇

TR-Gear for interface analog EN ISO 9409-1-A optimized for precision-rack-system

安裝節圓-Ø50，直齒類
bolt circle-Ø 50, straight tooth system

(可實現的裝配方案)
(Realistic Assembly solution)

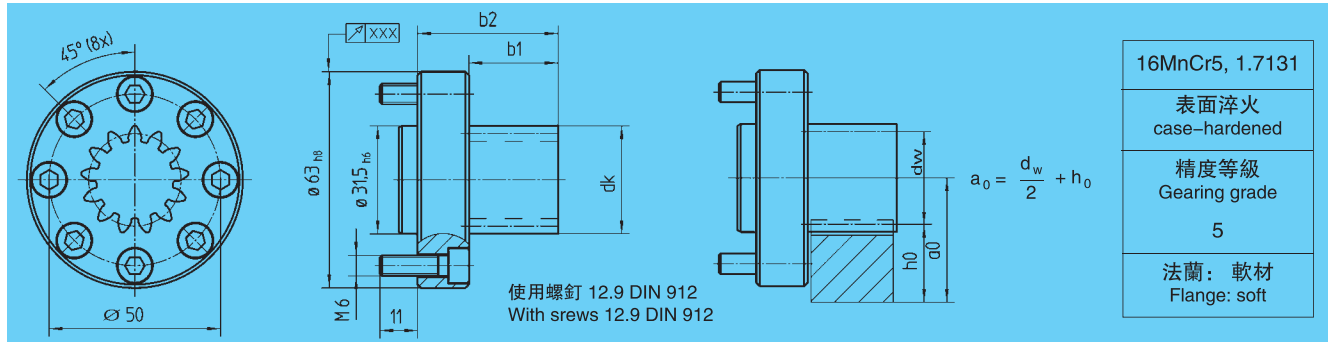

訂貨號 Order code	齒數 No. of teeth z	變位系數 Profile modif. factor x	分度圓直徑 Pitch circle-Ø [mm] d _w	齒頂圓直徑 Tip circle-Ø [mm] d _k	齒寬 Teeth width [mm] b ₁	總寬 total width [mm] b ₂	周長 L=PI*d [mm] L	中心距 Centre distance [mm] a ₀ ⁽¹⁾	安裝面 Interface ISO	kg	最大扭矩 max. torque [Nm] T _{max.} ⁽¹⁾	最大切綫載荷 tangential load max. [kN] F _t ⁽¹⁾
模數 2 / Module 2												
78 21 813	13	0,366	27,47	31,5	26	41	81,68	35,73	9409-1-A-50		70	5,1
78 21 814*	14	0,397	29,59	33,6	26	41	87,96	36,79	9409-1-A-50		85	5,7
78 21 815*	15	0,227	30,91	34,9	26	41	94,25	37,45	9409-1-A-50		95	6,1
78 21 816*	16	-0,042	31,83	35,8	26	41	100,53	37,92	9409-1-A-50		90	5,7
78 21 817	17	-0,012	33,95	38,0	26	41	106,81	38,98	9409-1-A-50		113	6,7

安裝節圓-Ø63，直齒類
bolt circle-Ø 63, straight tooth system

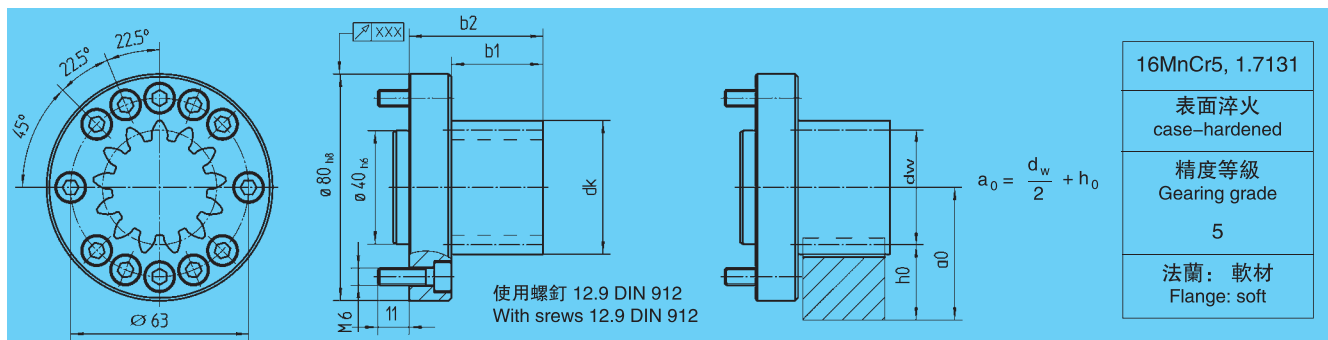

訂貨號 Order code	齒數 No. of teeth z	變位系數 Profile modif. factor x	分度圓直徑 Pitch circle-Ø [mm] d _w	齒頂圓直徑 Tip circle-Ø [mm] d _k	齒寬 Teeth width [mm] b ₁	總寬 total width [mm] b ₂	周長 L=PI*d [mm] L	中心距 Centre distance [mm] a ₀ ⁽¹⁾	安裝面 Interface ISO	kg	最大扭矩 max. torque [Nm] T _{max.} ⁽¹⁾	最大切綫載荷 tangential load max. [kN] F _t ⁽¹⁾
模數 2 / Module 2												
78 22 813	13	0,366	27,47	31,5	26	41	81,68	35,73	9409-1-A-63		70	5,1
78 22 814*	14	0,397	29,59	33,6	26	41	87,96	36,79	9409-1-A-63		85	5,7
78 22 815*	15	0,227	30,91	34,9	26	41	94,25	37,45	9409-1-A-63		95	6,1
78 22 816*	16	-0,042	31,83	35,8	26	41	100,53	37,92	9409-1-A-63		90	5,7
78 22 817*	17	-0,012	33,95	38,0	26	41	106,81	38,98	9409-1-A-63		113	6,7
78 22 818*	18	0,019	36,08	40,1	26	41	113,10	40,04	9409-1-A-63		136	7,5
78 22 819*	19	0,049	38,20	42,2	26	41	119,38	41,10	9409-1-A-63		160	8,4
78 22 820*	20	0,080	40,32	44,3	26	41	125,66	42,16	9409-1-A-63		185	9,2
78 22 821*	21	0,110	42,44	46,4	26	41	131,95	43,22	9409-1-A-63		210	9,9
78 22 822*	22	0,141	44,56	48,6	26	41	138,23	44,28	9409-1-A-63		235	10,5
78 22 823*	23	0,172	46,69	50,7	26	41	144,51	45,34	9409-1-A-63		245	10,5
78 22 824	24	0,202	48,81	52,8	26	41	150,80	46,40	9409-1-A-63		255	10,5
模數 3 / Module 3												
78 32 813	13	0,366	41,20	47,2	32,5	47,5	122,52	46,60	9409-1-A-63		200	9,7
78 32 814*	14	0,397	44,38	50,4	32,5	47,5	131,95	48,19	9409-1-A-63		245	11,0
78 32 815*	15	0,227	46,36	52,4	32,5	47,5	141,37	49,18	9409-1-A-63		265	11,4

* 按需求供應 / On request (1) 與ATLANTA齒條配合使用 / Values fit for ATLANTA-racks; 材料 / Material: m=2...4 16MnCr5, m=5...8: C45



ATLANTA

TR系列齒輪連接面符合EN ISO 9409-1-A標準
高精度齒條的最佳選擇

TR-Gear for interface analog EN ISO 9409-1-A optimized for precision-rack-system

安裝節圓-Ø80，直齒類
bolt circle-ø 80, straight tooth system

(可實現的裝配方案)
(Realistic Assembly solution)

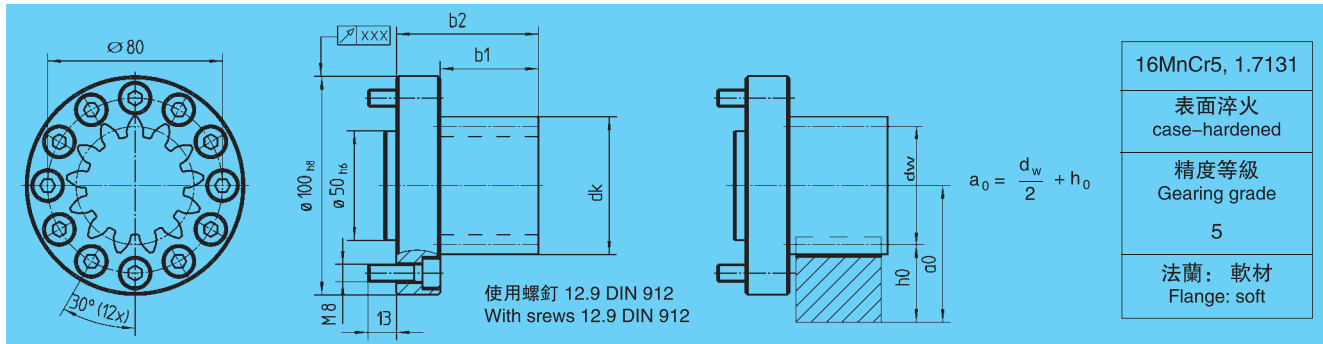

訂貨號 Order code	齒數 No. of teeth z	變位系數 Profile modif. factor x	分度圓直徑 Pitch-circle-ø [mm] d_w	齒頂圓直徑 Tip circle-ø [mm] d_k	齒寬 Teeth width [mm] b_1	總寬 total width [mm] b_2	周長 L=PI*d [mm] L	中心距 Centre distance [mm] $a_0^{(1)}$	安裝面 Interface ISO	最大扭矩 max. torque [Nm] $T_{max.}^{(1)}$	最大切綫載荷 tangential load max. [kN] $F_t^{(1)}$
模數 2 / Module 2											
78 23 813	13	0,366	27,47	31,5	26	46	81,68	35,73	9409-1-A-80	70	5,1
78 23 814*	14	0,397	29,59	33,6	26	46	87,96	36,79	9409-1-A-80	85	5,7
78 23 815*	15	0,227	30,91	34,9	26	46	94,25	37,45	9409-1-A-80	95	6,1
78 23 816*	16	-0,042	31,83	35,8	26	46	100,53	37,92	9409-1-A-80	90	5,7
78 23 817*	17	-0,012	33,95	38,0	26	46	106,81	38,98	9409-1-A-80	113	6,7
78 23 818*	18	0,019	36,08	40,1	26	46	113,10	40,04	9409-1-A-80	136	7,5
78 23 819*	19	0,049	38,20	42,2	26	46	119,38	41,10	9409-1-A-80	160	8,4
78 23 820*	20	0,080	40,32	44,3	26	46	125,66	42,16	9409-1-A-80	185	9,2
78 23 821*	21	0,110	42,44	46,4	26	46	131,95	43,22	9409-1-A-80	210	9,9
78 23 822*	22	0,141	44,56	48,6	26	46	138,23	44,28	9409-1-A-80	235	10,5
78 23 823*	23	0,172	46,69	50,7	26	46	144,51	45,34	9409-1-A-80	245	10,5
78 23 824	24	0,202	48,81	52,8	26	46	150,80	46,40	9409-1-A-80	255	10,5
78 23 825*	25	0,233	50,93	54,9	26	46	157,08	47,47	9409-1-A-80	265	10,5
78 23 826*	26	0,263	53,05	57,1	26	46	163,36	48,53	9409-1-A-80	278	10,5
78 23 827*	27	0,294	55,17	59,2	26	46	169,65	49,59	9409-1-A-80	290	10,5
78 23 828*	28	0,324	57,30	61,3	26	46	175,93	50,65	9409-1-A-80	300	10,5
78 23 829*	29	0,354	59,42	63,4	26	46	182,21	51,71	9409-1-A-80	313	10,5
78 23 830*	30	0,385	61,54	65,5	26	46	188,50	52,77	9409-1-A-80	323	10,5
78 23 831*	31	-0,115	61,54	65,5	26	46	194,78	52,77	9409-1-A-80	323	10,5
模數 3 / Module 3											
78 33 813	13	0,366	41,20	47,2	32,5	52,5	122,52	46,60	9409-1-A-80	200	9,7
78 33 814*	14	0,397	44,38	50,4	32,5	52,5	131,95	48,19	9409-1-A-80	245	11,0
78 33 815*	15	0,227	46,36	52,4	32,5	52,5	141,37	49,18	9409-1-A-80	265	11,4
78 33 816*	16	-0,042	47,75	53,7	32,5	52,5	150,80	49,87	9409-1-A-80	245	10,3
78 33 817*	17	-0,012	50,93	56,9	32,5	52,5	160,22	51,47	9409-1-A-80	315	12,4
78 33 818*	18	0,019	54,11	60,1	32,5	52,5	169,65	53,06	9409-1-A-80	380	14,0
78 33 819*	19	0,049	57,30	63,3	32,5	52,5	179,07	54,65	9409-1-A-80	445	15,5
78 33 820	20	0,080	60,48	66,5	32,5	52,5	188,50	56,24	9409-1-A-80	515	17,0
模數 4 / Module 4											
78 43 813	13	0,366	54,93	62,9	45	65	163,36	62,47	9409-1-A-80	475	17,3
78 43 814*	14	0,397	59,17	67,2	45	65	175,93	64,59	9409-1-A-80	585	19,8

* 按需求供應/ On request (1) 與ATLANTA齒條配合使用 / Values fit for ATLANTA-racks; 材料 / Material: m=2...4 16MnCr5, m=5...8: C45



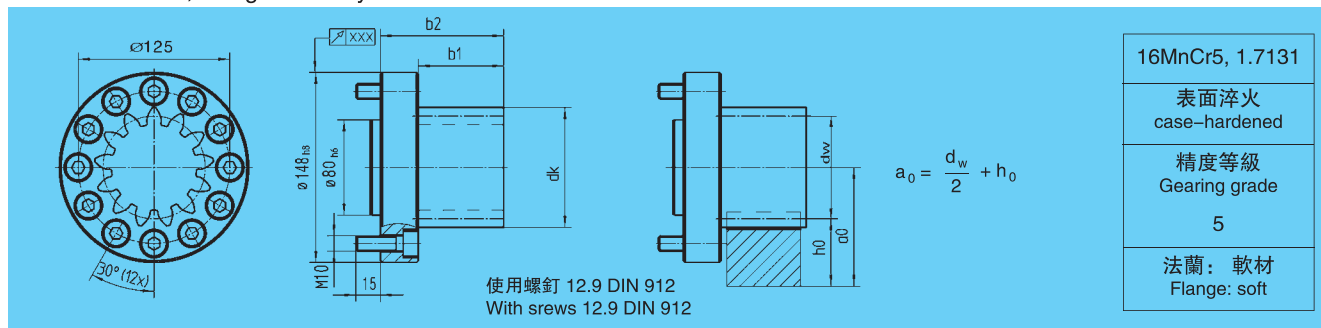

安裝節圓-Ø125, 直齒類 bolt circle-Ø 125, straight tooth system

(可實現的裝配方案)
(Realistic Assembly solution)

訂貨號 Order code	齒數 No. of teeth z	變位系數 Profile modif. factor x	分度圓直徑 Pitch-circle-ø [mm] d_w	齒頂圓直徑 Tip circle-ø [mm] d_k	齒寬 Teeth width [mm] b_1	總寬 total width [mm] b_2	周長 $L=PI*d$ [mm] L	中心距 Centre distance [mm] $a_0^{(1)}$	安裝面 Interface ISO	最大扭矩 max. torque [Nm] $T_{max.}^{(1)}$	最大切綫載荷 max. load [kN] $F_t^{(1)}$
模數 3 / Module 3											
78 34 813	13	0,366	41,20	47,2	32,5	57,5	122,52	46,60	9409-1-A-125	200	9,7
78 34 814*	14	0,397	44,38	50,4	32,5	57,5	131,95	48,19	9409-1-A-125	245	11,0
78 34 815*	15	0,227	46,36	52,4	32,5	57,5	141,37	49,18	9409-1-A-125	265	11,4
78 34 816*	16	-0,042	47,75	53,7	32,5	57,5	150,80	49,87	9409-1-A-125	245	10,3
78 34 817*	17	-0,012	50,93	56,9	32,5	57,5	160,22	51,47	9409-1-A-125	315	12,4
78 34 818*	18	0,019	54,11	60,1	32,5	57,5	169,65	53,06	9409-1-A-125	380	14,0
78 34 819*	19	0,049	57,30	63,3	32,5	57,5	179,07	54,65	9409-1-A-125	445	15,5
78 34 820	20	0,080	60,48	66,5	32,5	57,5	188,50	56,24	9409-1-A-125	515	17,0
78 34 821*	21	0,110	63,66	69,7	32,5	57,5	197,92	57,83	9409-1-A-125	590	18,5
78 34 822*	22	0,141	66,85	72,8	32,5	57,5	207,35	59,42	9409-1-A-125	670	20,0
78 34 823*	23	0,171	70,03	76,0	32,5	57,5	216,77	61,01	9409-1-A-125	700	20,0
78 34 824*	24	0,202	73,21	79,2	32,5	57,5	226,19	62,61	9409-1-A-125	733	20,0
78 34 825*	25	0,232	76,39	82,4	32,5	57,5	235,62	64,20	9409-1-A-125	765	20,0
78 34 826*	26	0,263	79,58	85,6	32,5	57,5	245,04	65,79	9409-1-A-125	795	20,0
78 34 827*	27	0,294	82,76	88,8	32,5	57,5	254,47	67,38	9409-1-A-125	828	20,0
78 34 828*	28	0,324	85,94	91,9	32,5	57,5	263,89	68,97	9409-1-A-125	860	20,0
78 34 829*	29	0,354	89,13	95,1	32,5	57,5	273,32	70,56	9409-1-A-125	890	20,0
78 34 830*	30	0,385	92,31	98,3	32,5	57,5	282,74	72,16	9409-1-A-125	925	20,0
78 34 831*	31	0,416	95,49	101,5	32,5	57,5	292,17	73,75	9409-1-A-125	955	20,0
78 34 832*	32	0,446	98,68	104,7	32,5	57,5	301,59	75,34	9409-1-A-125	985	20,0
78 34 833*	33	0,477	101,86	107,9	32,5	57,5	311,02	76,93	9409-1-A-125	1020	20,0
78 34 834*	34	-0,024	101,86	107,9	32,5	57,5	320,44	76,93	9409-1-A-125	1020	20,0
模數 4 / Module 4											
78 44 813	13	0,366	54,93	62,9	45	70	163,36	62,47	9409-1-A-125	475	17,3
78 44 814*	14	0,397	59,17	67,2	45	70	175,93	64,59	9409-1-A-125	585	19,8
78 44 815*	15	0,227	61,82	69,8	45	70	188,50	65,91	9409-1-A-125	635	20,5
78 44 816*	16	-0,042	63,66	71,7	45	70	201,06	66,83	9409-1-A-125	575	18,1
78 44 817*	17	-0,012	67,91	75,9	45	70	213,63	68,95	9409-1-A-125	750	22,1
78 44 818*	18	0,019	72,15	80,2	45	70	226,19	71,08	9409-1-A-125	910	25,2
78 44 819*	19	0,049	76,39	84,4	45	70	238,76	73,20	9409-1-A-125	1075	28,1
78 44 820*	20	0,110	81,52	89,5	45	70	256,10	75,76	9409-1-A-125	1225	30,4
78 44 821	21	0,110	84,88	92,9	45	70	263,89	77,44	9409-1-A-125	1700	33,0
78 44 822*	22	0,141	89,13	97,1	45	70	276,46	79,56	9409-1-A-125	1590	35,7
78 44 823*	23	0,171	93,37	101,4	45	70	289,03	81,69	9409-1-A-125	1665	35,7
78 44 824*	24	0,202	97,61	105,6	45	70	301,59	83,81	9409-1-A-125	1740	35,7
模數 5 / Module 5											
78 54 813	13	0,366	68,66	78,7	55	80	204,20	68,33	9409-1-A-125	625	18,2
78 54 814*	14	0,397	73,97	84,0	55	80	219,91	70,98	9409-1-A-125	725	19,6
78 54 815*	15	0,227	77,27	87,3	55	80	235,62	72,64	9409-1-A-125	850	22,0
78 54 816*	16	-0,042	79,58	89,6	55	80	251,33	73,79	9409-1-A-125	950	23,9
78 54 817*	17	-0,012	84,88	94,9	55	80	267,04	76,44	9409-1-A-125	1150	27,1
78 54 818*	18	0,019	90,19	100,2	55	80	282,74	79,09	9409-1-A-125	1325	29,4
78 54 819	19	0,049	95,49	105,5	55	80	298,45	81,75	9409-1-A-125	1500	31,4
模數 6 / Module 6											
78 64 813	13	0,366	82,40	94,4	65	90	245,04	84,20	9409-1-A-125	1030	25,5
78 64 814*	14	0,397	88,76	100,8	65	90	263,89	87,38	9409-1-A-125	1225	27,6
78 64 815*	15	0,227	92,73	104,7	65	90	282,74	89,36	9409-1-A-125	1475	31,8
78 64 816	16	-0,042	95,49	107,5	65	90	301,59	90,75	9409-1-A-125	1625	34,0

* 按需求供應 / On request (1) 與ATLANTA齒條配合使用 / Values fit for ATLANTA-racks; 材料 / Material: m=2...4 16MnCr5, m=5...8: C45



ATLANTA

TR系列齒輪連接面符合EN ISO 9409-1-A標準
高精度齒條的最佳選擇

TR-Gear for interface analog EN ISO 9409-1-A optimized for precision-rack-system

安裝節圓-Ø140, 直齒類
bolt circle-Ø 140, straight tooth system

(可實現的裝配方案)
(Realistic Assembly solution)

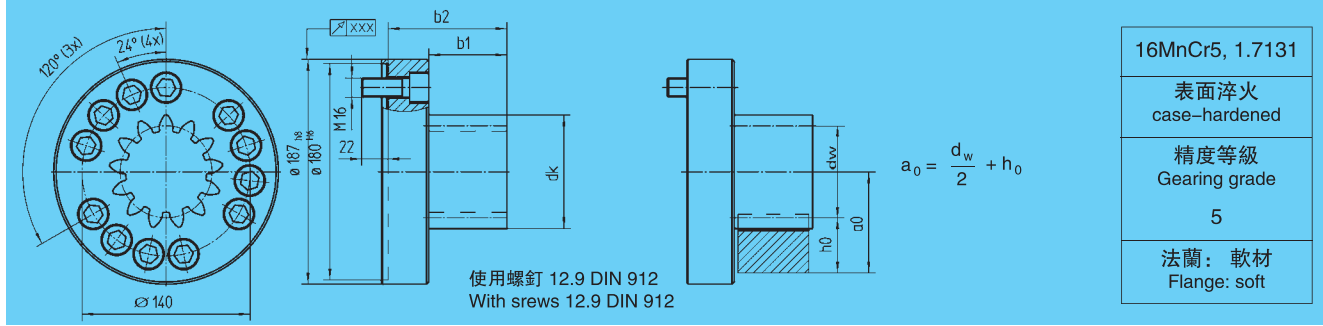

訂貨號 Order code	齒數 No. of teeth z	變位係數 Profile modif. factor x	分度圓直徑 Pitch-circle-Ø [mm] d_w	齒頂圓直徑 Tip circle-Ø [mm] d_k	齒寬 Teeth width [mm] b_1	總寬 total width [mm] b_2	周長 $L=PI*d$ [mm] L	中心距 Centre distance [mm] $a_0^{(1)}$	安裝面 Interface ISO	最大扭矩 max. torque [Nm] $T_{max}^{(1)}$	最大切綫載荷 tangential load max. [kN] $F_t^{(1)}$
模數 4 / Module 4											
78 46 813	13	0,366	54,93	62,9	45	79	163,36	62,47	-	475	17,3
78 46 814*	14	0,397	59,17	67,2	45	79	175,93	64,59	-	585	19,8
78 46 815*	15	0,227	61,82	69,8	45	79	188,50	65,91	-	635	20,5
78 46 816*	16	-0,042	63,66	71,7	45	79	201,06	66,83	-	575	18,1
78 46 817*	17	-0,012	67,91	75,9	45	79	213,63	68,95	-	750	22,1
78 46 818*	18	0,019	72,15	80,2	45	79	226,19	71,08	-	910	25,2
78 46 819*	19	0,049	76,39	84,4	45	79	238,76	73,20	-	1075	28,1
78 46 820*	20	0,110	81,52	89,5	45	79	256,10	75,76	-	1225	30,4
78 46 821	21	0,110	84,88	92,9	45	79	263,89	77,44	-	1400	33,0
78 46 822*	22	0,141	89,13	97,1	45	79	276,46	79,56	-	1590	35,7
78 46 823*	23	0,171	93,37	101,4	45	79	289,03	81,69	-	1665	35,7
78 46 824*	24	0,202	97,61	105,6	45	79	301,59	83,81	-	1740	35,7
78 46 825*	25	0,232	101,86	109,9	45	79	314,16	85,93	-	1820	35,7
78 46 826*	26	0,263	106,10	114,1	45	79	326,73	88,05	-	1895	35,7
模數 5 / Module 5											
78 56 813*	13	0,366	68,66	78,7	55	89	204,20	68,33	-	625	18,2
78 56 814*	14	0,397	73,97	84,0	55	89	219,91	70,98	-	725	19,6
78 56 815	15	0,227	77,27	87,3	55	89	235,62	72,64	-	850	22,0
78 56 816*	16	-0,042	79,58	89,6	55	89	251,33	73,79	-	950	23,9
78 56 817*	17	-0,012	84,88	94,9	55	89	267,04	76,44	-	1150	27,1
78 56 818*	18	0,019	90,19	100,2	55	89	282,74	79,09	-	1325	29,4
78 56 819*	19	0,049	95,49	105,5	55	89	298,45	81,75	-	1500	31,4
78 56 820	20	0,080	100,80	110,8	55	89	314,16	84,40	-	1700	33,7
78 56 821*	21	0,110	106,10	116,1	55	89	329,87	87,05	-	1825	34,4
模數 6 / Module 6											
78 66 813	13	0,366	82,40	94,4	65	99	245,04	84,20	-	1030	25,0
78 66 814*	14	0,397	88,76	100,8	65	99	263,89	87,38	-	1225	27,6
78 66 815*	15	0,227	92,73	104,7	65	99	282,74	89,36	-	1475	31,8
78 66 816*	16	-0,042	95,49	107,5	65	99	301,59	90,75	-	1625	34,0
78 66 817	17	-0,012	101,86	113,9	65	99	320,44	93,93	-	1950	38,3

* 按需求供應 / On request (1) 與ATLANTA齒條配合使用 / Values fit for ATLANTA-racks; 材料 / Material: m=2...4 16MnCr5, m=5...8: C45





安裝節圓-Ø160, 直齒類
bolt circle-Ø 160, straight tooth system

(可實現的裝配方案)
(Assemblage of the realizable types)

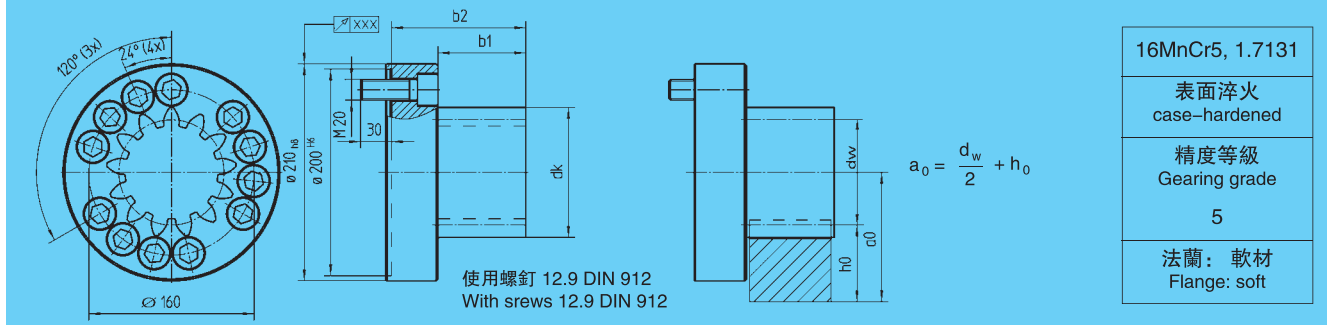

訂貨號 Order code	齒數 No. of teeth	變位系數 Profile modif. factor	分度圓直徑 Pitch-circle-ø [mm]	齒頂圓直徑 Tip circle-ø [mm]	齒寬 Teeth width [mm]	總寬 total width [mm]	周長 L=PI*d [mm]	中心距 Centre distance [mm]	安裝面 Interface	kg	最大扭矩 max. torque [Nm]	最大切綫載荷 tangential load max. [kN]
	z	x	dw	dk	b1	b2	L	a0 ⁽¹⁾	ISO		Tmax. ⁽¹⁾	Ft ⁽¹⁾

模數 5 / Module 5

78 57 813	13	0,366	68,66	78,7	55	89	204,20	68,33	-		625	18,2
78 57 814*	14	0,397	73,97	84,0	55	89	219,91	70,98	-		725	19,6
78 57 815*	15	0,227	77,27	87,3	55	89	235,62	72,64	-		850	22,0
78 57 816*	16	-0,042	79,58	89,6	55	89	251,33	73,79	-		950	23,9
78 57 817*	17	-0,012	84,88	94,9	55	89	267,04	76,44	-		1150	27,1
78 57 818*	18	0,019	90,19	100,2	55	89	282,74	79,09	-		1325	29,4
78 57 819*	19	0,049	95,49	105,5	55	89	298,45	81,75	-		1500	31,4
78 57 820	20	0,080	100,80	110,8	55	89	314,16	84,40	-		1700	33,7
78 57 821*	21	0,110	106,10	116,1	55	89	329,87	87,05	-		1825	34,4
78 57 822*	22	0,141	111,41	121,4	55	89	345,58	89,70	-		2000	35,9
78 57 823*	23	0,171	116,71	126,7	55	89	361,28	92,36	-		2200	37,7

模數 6 / Module 6

78 67 813	13	0,366	82,39	94,4	65	99	245,04	84,20	-		1030	25,0
78 67 814*	14	0,397	88,76	100,8	65	99	263,89	87,38	-		1225	27,6
78 67 815*	15	0,227	92,73	104,7	65	99	282,74	89,36	-		1475	31,8
78 67 816*	16	-0,042	95,49	107,5	65	99	301,59	90,75	-		1625	34,0
78 67 817	17	-0,012	101,86	113,9	65	99	320,44	93,93	-		1950	38,3
78 67 818*	18	0,019	108,23	120,2	65	99	339,29	97,11	-		2300	42,5
78 67 819*	19	0,049	114,59	126,6	65	99	358,14	100,30	-		2600	45,4

模數 8 / Module 8

78 87 813	13	0,366	109,86	125,9	85	119	326,73	125,93	-		2500	45,5
-----------	----	-------	--------	-------	----	-----	--------	--------	---	--	------	------

* 按需求供應 / On request ⁽¹⁾ 與ATLANTA齒條配合使用 / Values fit for ATLANTA-racks; 材料 / Material: m=2...4 16MnCr5, m=5...8: C45



直齒類，磨削加工齒，20° 壓力角，孔徑 \varnothing^{H6} 和鍵槽符合標準 DIN 6885。

Straight tooth system, ground teeth, 20° transverse pressure angle, with bore \varnothing^{H6} and keyway acc. to DIN 6885

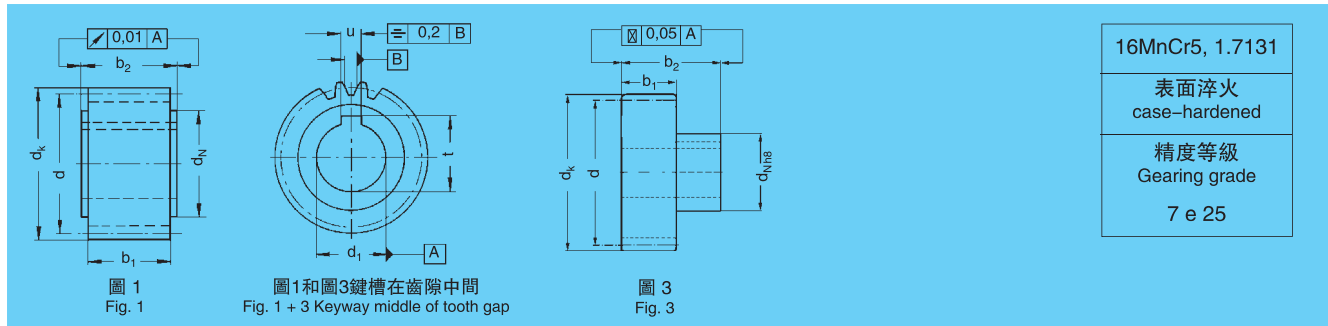

訂貨號 Order code	圖 Fig.	齒數 N° of teeth z	d	d _k	d ₁ ^{H6}	d _N	b ₁	b ₂	u	t	kg	軸襯 見 GF-9 shrink-disc on page GF-9
-------------------	-----------	------------------------	---	----------------	------------------------------	----------------	----------------	----------------	---	---	----	---

模數 / Module 2												
24 21 216	1	16	32	36	15	25	28	30,0	5	17,3	0,1	
24 21 218	1	18	36	40	15	28	28	30,0	5	17,3	0,2	
24 22 218	1	18	36	40	20	28	28	30,0	6	22,8	0,2	
24 21 220	1	20	40	44	15	25	28	30,0	5	17,3	0,2	
24 29 420	3	20	40	44	19*	30	28	30,0	6	21,8		80 83 030
24 29 220	1	20	40	44	19*	30	28	30,0	6	21,8		
24 22 220	1	20	40	44	20*	30	28	30,0	6	22,8	0,2	
24 20 120	3	20	40	44	22*	36	28	56,0	6	24,8		80 84 036
24 20 220	1	20	40	44	22*	30	28	30,0	6	24,8	0,2	
24 21 222	1	22	44	48	15	25	28	30,0	5	17,3	0,3	
24 29 222	1	22	44	48	19*	30	28	30,0	6	21,8		
24 29 422	3	22	44	48	19*	30	28	56,0	6	21,8		80 83 030
24 22 222	1	22	44	48	20	30	28	30,0	6	22,8	0,3	
24 20 222	1	22	44	48	22*	30	28	30,0	6	24,8	0,2	
24 20 122	3	22	44	48	22	36	28	56,0	6	27,8		80 84 036
24 23 222	1	22	44	48	25	36	28	30,0	8	28,3	0,2	
24 21 225	1	25	50	54	15	25	28	30,0	5	17,3	0,4	
24 26 225	3	25	50	54	16	30	28	54,0	5	18,3	0,3	80 83 030
24 29 225	1	25	50	54	19*	30	28	30,0	6	21,8		
24 29 425	3	25	50	54	19*	30	28	56,0	6	21,8		80 83 030
24 22 225	1	25	50	54	20	30	28	30,0	6	22,8	0,4	
24 20 225	1	25	50	54	22	30	28	30,0	6	24,8	0,3	
24 20 425	3	25	50	54	22*	36	28	56,0	6	24,8	0,4	80 84 036
24 23 225	1	25	50	54	25	36	28	30,0	8	28,3	0,3	
24 24 225	1	25	50	54	30	45	28	30,0	8	33,3	0,3	
24 21 228	1	28	56	60	15	25	28	30,0	5	17,3		
24 29 228	1	28	56	60	19*	30	28	30,0	6	21,8		
24 29 428	3	28	56	60	19*	30	28	56,0	6	21,8		80 83 030
24 22 228	1	28	56	60	20	30	28	30,0	6	22,8	0,5	
24 20 128	3	28	56	60	22*	36	28	56,0	6	24,8	0,3	80 84 036
24 20 228	1	28	56	60	22*	30	28	30,0	6	24,8	0,3	
24 23 228	1	28	56	60	25	36	28	30,0	8	28,3	0,4	
24 22 428	3	28	56	60	30	50	28	60,0	8	33,3	0,4	80 85 050
24 24 228	1	28	56	60	30	45	28	30,0	8	33,3	0,4	
24 25 228	1	28	56	60	35	48	28	30,0	10	38,3	0,3	
24 21 232	1	32	64	68	15	36	28	30,0	5	17,3	0,6	
24 26 232	3	32	64	68	16	30	28	54,0	5	18,3	0,6	80 83 030
24 22 232	1	32	64	68	20	30	28	30,0	6	22,8	0,6	
24 20 232	1	32	64	68	22*	30	28	30,0	6	24,8	0,4	
24 20 432	3	32	64	68	22	36	28	56,0	6	24,8	0,6	80 84 036
24 23 232	1	32	64	68	25	36	28	30,0	8	28,3	0,6	
24 22 432	3	32	64	68	30	50	28	60,0	8	33,3	0,6	80 85 050
24 24 232	1	32	64	68	30	45	28	30,0	8	33,3	0,6	
24 23 432	3	32	64	68	32	55	28	65,0	10	35,3	0,5	80 80 055
24 25 232	1	32	64	68	35	48	28	30,0	10	38,3	0,5	
24 22 236	1	36	72	76	20	30	28	30,0	6	22,8	0,8	
24 23 236	1	36	72	76	25	36	28	30,0	8	28,3	0,8	
24 24 236	1	36	72	76	30	45	28	30,0	8	33,3	0,7	
24 25 236	1	36	72	76	35	48	28	30,0	10	38,3	0,7	
24 25 436	3	36	72	76	40	62	28	65,0	12	43,3	0,5	80 86 062
24 27 236	1	36	72	76	45	58	28	30,0	14	48,8	0,6	

* G6 bzw./resp. H7





直齒類，磨削加工齒，20° 壓力角，孔徑 \varnothing^{H6} 和鍵槽符合標準 DIN 6885。

Straight tooth system, ground teeth, 20° transverse pressure angle, with bore \varnothing^{H6} and keyway acc. to DIN 6885

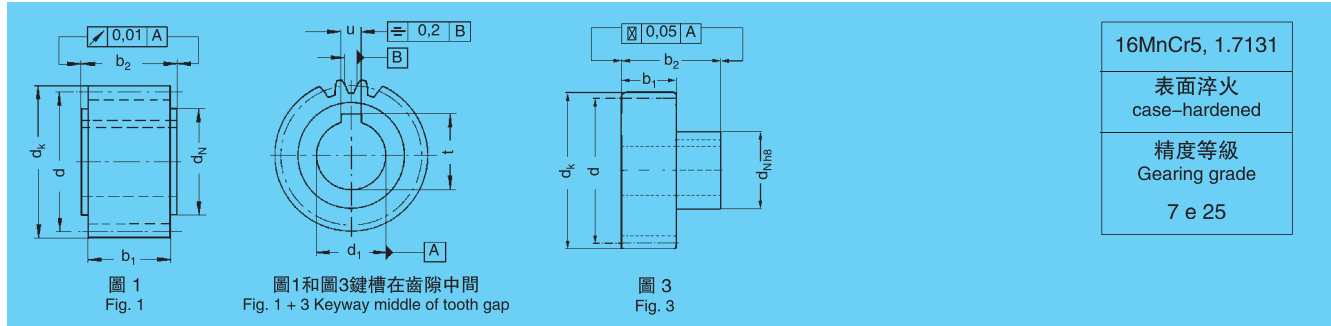

16MnCr5, 1.7131
表面淬火 case-hardened
精度等級 Gearing grade
7 e 25

訂貨號 Order code	圖 Fig.	齒數 N° of teeth z	d	d _k	d ₁ ^{H6}	d _N	b ₁	b ₂	u	t	kg	軸襯 見 GF-9 shrink-disc on page GF-9
模數 / Module 2												
24 21 240	1	40	80	84	15	36	28	30,0	5	17,3	1,0	
24 22 240	1	40	80	84	20	30	28	30,0	6	22,8	1,0	
24 23 240	1	40	80	84	25	36	28	30,0	8	28,3	1,0	
24 24 240	1	40	80	84	30	45	28	30,0	8	33,3	1,0	
24 23 440	3	40	80	84	32	55	28	65,0	10	35,3	0,9	80 85 050
24 25 240	1	40	80	84	35	48	28	30,0	10	38,3	0,9	
24 25 440	3	40	80	84	40	62	28	65,0	12	43,3	0,7	80 86 062
24 26 440	3	40	80	84	45	68	28	65,0	14	48,8	1,3	80 80 068
24 27 240	1	40	80	84	45	58	28	30,0	14	48,8	0,8	
24 22 245	1	45	90	94	20	30	28	30,0	6	22,8	1,3	
24 23 245	1	45	90	94	25	36	28	30,0	8	28,3	1,2	
24 25 245	1	45	90	94	35	48	28	30,0	10	38,3	1,2	
24 27 245	1	45	90	94	45	58	28	30,0	14	48,8	1,1	
24 22 250	1	50	100	104	20	30	28	30,0	6	22,8	1,6	
24 23 250	1	50	100	104	25	36	28	30,0	8	28,3	1,5	
24 25 250	1	50	100	104	35	48	28	30,0	10	38,3	1,5	
24 27 250	1	50	100	104	45	58	28	30,0	14	48,8	1,4	
24 26 450	3	50	100	104	45	68	28	65,0	14	48,8	2,0	80 80 068
24 23 256	1	56	112	116	25	36	28	30,0	8	28,3	1,9	
24 25 256	1	56	112	116	35	48	28	30,0	10	38,3	1,8	
24 23 263	1	63	126	130	25	36	28	30,0	8	28,3	2,5	
24 25 271	1	71	142	146	35	48	28	30,0	10	38,3	3,15	
24 25 280	1	80	160	164	35	48	28	30,0	10	38,3	4,2	
24 27 290	1	90	180	184	45	58	28	30,0	14	48,8	5,7	



直齒類，磨削加工齒，20° 壓力角，孔徑 \varnothing^{H6} 和鍵槽符合標準 DIN 6885。

Straight tooth system, ground teeth, 20° transverse pressure angle, with bore \varnothing^{H6} and keyway acc. to DIN 6885

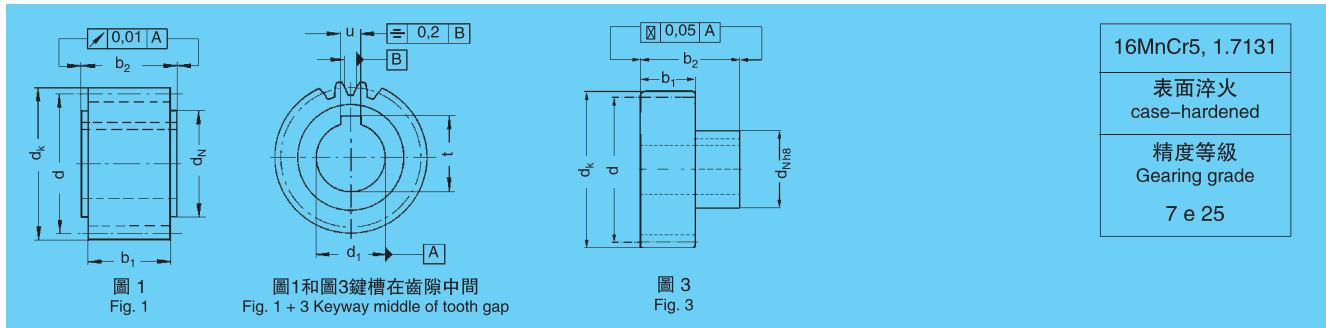

16MnCr5, 1.7131
表面淬火 case-hardened
精度等級 Gearing grade
7 e 25

訂貨號 Order code	圖 Fig.	齒數 N° of teeth z	d	d _k	d ₁ ^{H6}	d _N	b ₁	b ₂	u	t	kg	軸襯 見 GF-9 shrink-disc on page GF-9
模數 / Module 3												
24 33 218	1	18	54	60	25	36	28	30,0	8	28,3	0,4	
24 33 220	1	20	60	66	25	36	28	30,0	8	28,3	0,5	
24 34 220	1	20	60	66	30	45	28	30,0	8	33,3	0,5	
24 35 220	1	20	60	66	35	48	28	30,0	10	38,3	0,4	
24 30 422	3	22	66	72	22	36	28	56,0	6	24,8	0,8	80 84 036
24 31 422	3	22	66	72	25	44	28	60,0	8	28,3	0,9	80 80 044
24 33 222	1	22	66	72	25	36	28	30,0	8	28,3	0,6	
24 32 422	3	22	66	72	30	50	28	60,0	8	33,3	0,9	80 85 050
24 34 222	1	22	66	72	30	45	28	30,0	8	33,3	0,6	
24 33 422	3	22	66	72	32	55	28	65,0	10	35,3	1,0	80 80 055
24 34 422	3	22	66	72	35	55	28	65,0	10	38,3	0,9	80 80 055
24 35 222	1	22	66	72	35	48	28	30,0	10	38,3	0,6	
24 35 422	3	22	66	72	40*	62	28	65	12	43,3	1,0	80 86 062
24 33 225	1	25	75	81	25	36	28	30,0	8	28,3	0,9	
24 34 225	1	25	75	81	30	45	28	30,0	8	33,3	0,8	
24 33 425	3	25	75	81	32*	55	28	65	10	35,3	1,2	80 80 055
24 35 225	1	25	75	81	35	48	28	30,0	10	38,3	0,8	
24 35 425	3	25	75	81	40	62	28	65,0	12	43,3	1,2	80 86 062
24 37 225	1	25	75	81	45	58	28	30,0	14	48,8	0,6	
24 30 428	3	28	84	90	22	36	28	56,0	6	24,8	1,3	80 84 036
24 31 428	3	28	84	90	25	44	28	60,0	8	28,3	1,4	80 80 044
24 33 228	1	28	84	90	25	36	28	30,0	8	28,3	1,1	
24 32 428	3	28	84	90	30	50	28	60,0	8	33,3	1,4	80 85 050
24 34 228	1	28	84	90	30	45	28	30,0	8	33,3	1,1	
24 33 428	3	28	84	90	32	55	28	65,0	10	35,3	1,5	80 80 055
24 34 428	3	28	84	90	35	55	28	65,0	10	38,3	1,4	80 80 055
24 35 228	1	28	84	90	35	48	28	30,0	10	38,3	1,0	
24 35 428	3	28	84	90	40*	62	28	65	12	43,3	1,4	80 86 062
24 36 428	3	28	84	90	45	68	28	65,0	14	48,8	1,5	80 80 068
24 37 228	1	28	84	90	45	58	28	30,0	14	48,8	0,9	
24 33 232	1	32	96	102	25	36	28	30,0	8	28,3	1,5	
24 34 232	1	32	96	102	30	45	28	30,0	8	33,3	1,4	
24 33 432	3	32	96	102	32*	55	28	65	10	35,3	1,8	80 80 055
24 35 232	1	32	96	102	35	48	28	30,0	10	38,3	1,4	
24 35 432	3	32	96	102	40	62	28	65,0	12	43,3	1,8	80 86 062
24 37 232	1	32	96	102	45	58	28	30,0	14	48,8	1,3	
24 39 232	1	32	96	102	60	80	28	30,0	18	64,4	1,1	
24 33 236	1	36	108	114	25	36	28	30,0	8	28,3	1,9	
24 35 236	1	36	108	114	35	48	28	30,0	10	38,3	1,8	
24 36 436	3	36	108	114	45	68	28	65,0	14	48,8	2,2	80 80 068
24 37 236	1	36	108	114	45	58	28	30,0	14	48,8	1,7	
24 39 236	1	36	108	114	60	80	28	30,0	18	64,4	1,4	
24 33 240	1	40	120	126	25	36	28	30	8	28,3	2,3	
24 35 240	1	40	120	126	35	48	28	30,0	10	38,3	2,3	
24 37 240	1	40	120	126	45	58	28	30,0	14	48,8	2,1	
24 39 240	1	40	120	126	60	80	28	30,0	18	64,4	1,9	
24 33 245	1	45	135	141	25	36	28	30,0	8	28,3	3,0	
24 35 245	1	45	135	141	35	48	28	30,0	10	38,3	2,7	
24 37 245	1	45	135	141	45	58	28	30,0	14	48,8	2,4	

* G6 bzw./resp. H7



直齒類，磨削加工齒，20° 壓力角，孔徑 \varnothing^{H6} 和鍵槽符合標準 DIN 6885。

Straight tooth system, ground teeth, 20° transverse pressure angle, with bore \varnothing^{H6} and keyway acc. to DIN 6885

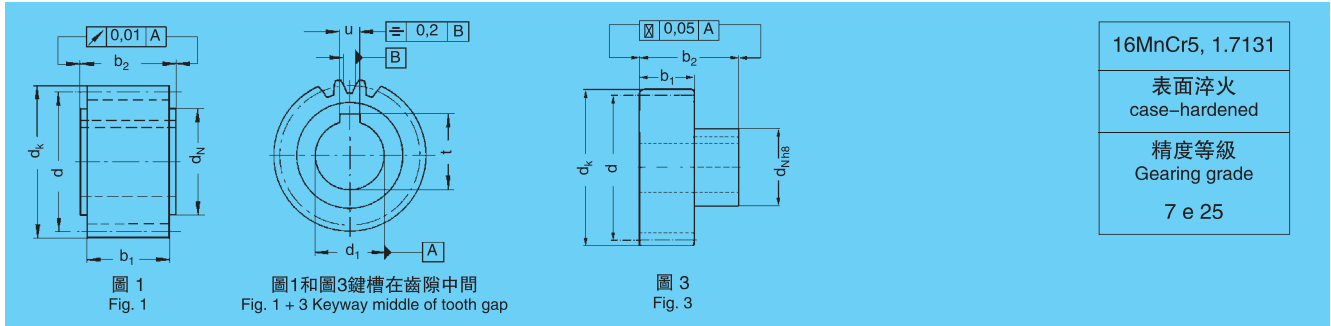

訂貨號 Order code	圖 Fig.	齒數 N° of teeth z	d	d _k	d ₁ ^{H6}	d _N	b ₁	b ₂	u	t	kg	軸襯 見 GF-9 shrink-disc on page GF-9
模數 / Module 3												
24 39 245	1	45	135	141	60	80	28	30,0	18	64,4	2,4	
24 35 250	1	50	150	156	35	48	28	30,0	10	38,3	3,6	
24 37 250	1	50	150	156	45	58	28	30	14	48,8	3,5	
24 37 256	1	56	168	174	45	58	28	30,0	14	48,8	4,4	
24 37 263	1	63	189	195	45	58	28	30,0	14	48,8	5,4	
24 39 263	1	63	189	195	60	80	28	30,0	18	64,4	5,4	



直齒類，磨削加工齒，20° 壓力角，孔徑 \varnothing^{H6} 和鍵槽符合標準 DIN 6885。
Straight tooth system, ground teeth, 20° transverse pressure angle, with bore \varnothing^{H6} and keyway acc. to DIN 6885

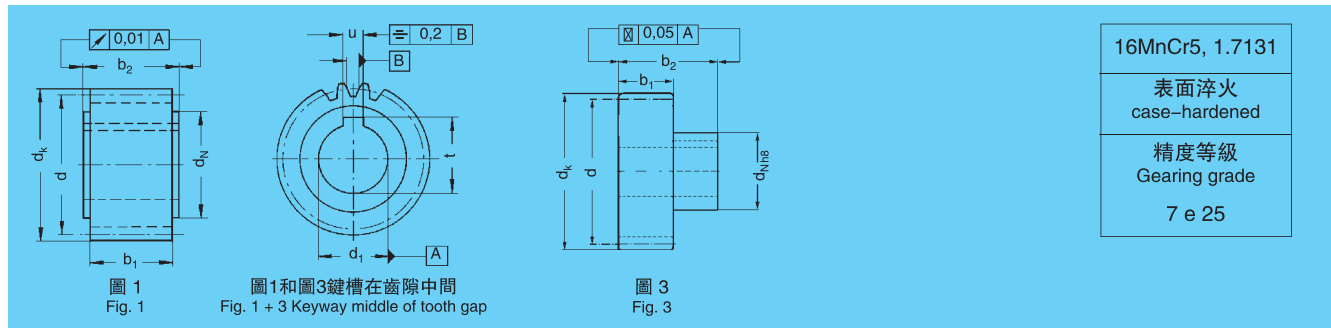

訂貨號 Order code	圖 Fig.	齒數 N° of teeth z	d	d _k	d ₁ ^{H6}	d _N	b ₁	b ₂	u	t	kg	軸襯 見 GF-9 shrink-disc on page GF-9
模數 / Module 4												
24 43 420	3	20	80	88	32	55	40	75,0	10	35,3	1,7	80 80 055
24 45 220	1	20	80	88	35	52	40	50,0	10	38,3	1,3	
24 44 420	3	20	80	88	35	55	40	75,0	10	38,3	1,7	80 80 055
24 45 420	3	20	80	88	40	62	40	75,0	12	43,3	1,7	80 86 062
24 47 220	1	20	80	88	45	65	40	50,0	14	48,8	1,2	
24 45 222	1	22	88	96	35	52	40	50,0	10	38,3	1,7	
24 47 222	1	22	88	96	45	65	40	50,0	14	48,8	1,5	
24 46 422	3	22	88	96	45	68	40	75,0	14	48,8	2,0	80 80 068
24 43 425	3	25	100	108	32	55	40	75,0	10	35,3	2,6	80 80 055
24 45 225	1	25	100	108	35	52	40	50,0	10	38,3	2,2	
24 44 425	3	25	100	108	35	55	40	75,0	10	38,3	2,5	80 80 055
24 45 425	3	25	100	108	40	62	40	75,0	12	43,3	2,5	80 86 062
24 47 225	1	25	100	108	45	65	40	50,0	14	48,8	2,0	
24 47 425	3	25	100	108	55	80	40	80,0	16	59,3	2,5	80 87 080
24 45 228	1	28	112	120	35	52	40	50,0	10	38,3	2,9	
24 47 228	1	28	112	120	45	65	40	50,0	14	48,8	2,7	
24 46 428	3	28	112	120	45	68	40	75,0	14	48,8	3,1	80 80 068
24 45 232	1	32	128	136	35	52	40	50,0	10	38,3	3,8	
24 47 232	1	32	128	136	45	65	40	50,0	14	48,8	3,7	
24 47 432	3	32	128	136	55	80	40	80,0	16	59,3	4,1	80 87 080
24 48 432	3	32	128	136	75	110	40	100,0	20	79,9	5,0	80 80 110
24 47 240	1	40	160	168	45	65	40	50,0	14	48,8	5,9	
24 49 240	1	40	160	168	60	80	40	50,0	18	64,4	5,6	
24 48 440	3	40	160	168	75	110	40	100,0	20	79,9	7,3	80 80 110





直齒類，磨削加工齒，20° 壓力角，孔徑 \varnothing^{H6} 和鍵槽符合標準 DIN 6885。

Straight tooth system, ground teeth, 20° transverse pressure angle, with bore \varnothing^{H6} and keyway acc. to DIN 6885

16MnCr5, 1.7131

表面淬火
case-hardened

精度等級
Gearing grade

7 e 25

鍵槽在齒隙中間
Keyway middle of tooth gap

訂貨號 Order code	齒數 N° of teeth z	d	d _k	d ₁ ^{H6}	d _N	b ₁	b ₂	u	t	kg	軸襯 見 GF-9 shrink-disc on page GF-9
模數 / Module 5											
24 56 421	21	105	115	45	68	50	85,0	14	48,8	3,7	80 80 068
24 57 421	21	105	115	55	80	50	90,0	16	59,3	3,7	80 87 080
24 56 425	25	125	135	45	68	50	85,0	14	48,8	5,2	80 80 068
24 57 425	25	125	135	55	80	50	90,0	16	59,3	5,1	80 87 080
24 58 425	25	125	135	75	110	50	110,0	20	80,4	4,7	80 80 110
模數 / Module 6											
24 67 421	21	126	138	55	80	60	100,0	16	59,3	5,6	80 87 080
24 68 421	21	126	138	75	110	60	120,0	20	79,9	4,7	80 80 110
24 67 425	25	150	162	55	80	60	100,0	16	59,3	8,0	80 87 080
24 68 425	25	150	162	75	110	60	120,0	20	79,9	7,1	80 80 110
模數 / Module 8											
24 88 420*	20	160	176	75	110	80	140	20	79,9	12,0	80 80 110
24 89 420*	20	160	176	85	125	80	145	22	90,4	12,1	80 80 125
模數 / Module 10											
24 09 620*	20	200	220	85	125	100	165	22	90,4	23	80 80 125

* 精度等級 5 f 23 / Gearing quality 5 f 23



直齒類，銑削加工齒，20° 壓力角
Straight tooth system, milled teeth, 20° transverse pressure angle



圖 / Fig. 1



圖 / Fig. 2

軟材 / soft	
C45, 1.0503	工程塑料 POM Plastic POM
精度等級 Gearing grade	精度等級 Gearing grade
8 e 25	9 bc 26

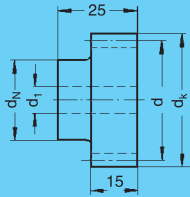
鋼鐵 Steel	訂貨號 Order code		圖 Fig.	齒數 N° of teeth z	d	dk	d1	dN	d3	s	kg	g
	工程塑料 Plastic	鋼鐵 Steel									工程塑料 Plastic	
21 10 012	22 10 012	1	12	12,0	14,0	6	9	-	-	-	0,01	2,0
21 10 013	22 10 013	1	13	13,0	15,0	6	9	-	-	-	0,01	2,5
21 10 014	22 10 014	1	14	14,0	16,0	6	11	-	-	-	0,02	3,0
21 10 015	22 10 015	1	15	15,0	17,0	6	12	-	-	-	0,02	4,0
21 10 016	22 10 016	1	16	16,0	18,0	6	12	-	-	-	0,03	4,5
21 10 017	22 10 017	1	17	17,0	19,0	6	14	-	-	-	0,03	5,0
21 10 018	22 10 018	1	18	18,0	20,0	6	15	-	-	-	0,04	6,0
21 10 019	22 10 019	1	19	19,0	21,0	6	15	-	-	-	0,04	8,0
21 10 020	22 10 020	1	20	20,0	22,0	6	16	-	-	-	0,05	10,0
21 10 021	22 10 021	1	21	21,0	23,0	6	16	-	-	-	0,05	12,0
21 10 022	22 10 022	1	22	22,0	24,0	6	18	-	-	-	0,06	14,0
21 10 023	22 10 023	1	23	23,0	25,0	6	18	-	-	-	0,06	15,0
21 10 024	22 10 024	1	24	24,0	26,0	9	20	-	-	-	0,07	17,0
21 10 025	22 10 025	1	25	25,0	27,0	9	20	-	-	-	0,07	20,0
21 10 030	22 10 030	1	30	30,0	32,0	9	20	-	-	-	0,10	25,0
21 10 035	22 10 035	1	35	35,0	37,0	9	25	-	-	-	0,14	28,0
21 10 038	22 10 038	1	38	38,0	40,0	9	25	-	-	-	0,17	32,0
21 10 040	22 10 040	1	40	40,0	42,0	9	25	-	-	-	0,18	35,0
21 10 045	22 10 045	1	45	45,0	47,0	9	30	-	-	-	0,25	45,0
21 10 048	22 10 048	1	48	48,0	50,0	9	30	-	-	-	0,26	48,0
21 10 050	22 10 050	1	50	50,0	52,0	9	30	-	-	-	0,28	50,0
21 10 057	22 10 057	1	57	57,0	59,0	9	40	-	-	-	0,37	68,0
21 10 060	22 10 060	1	60	60,0	62,0	9	40	-	-	-	0,40	75,0
23 10 076	-	2	76	76,0	78,0	10	-	-	-	-	0,55	-
23 10 080	-	2	80	80,0	82,0	10	-	-	-	-	0,60	-
23 10 095	-	2	95	95,0	97,0	10	-	-	-	-	0,85	-
23 10 100	-	2	100	100,0	102,0	10	-	-	-	-	0,95	-
23 10 114	-	2	114	114,0	116,0	10	-	-	-	-	1,20	-

可以很快進行追加工（打孔，開鍵槽，攻絲等）。
Further finishing (turning bores, keywaying, threading, etc.) is possible within short time.

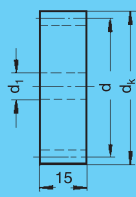



直齒類，銑削加工齒，20° 壓力角
Straight tooth system, milled teeth, 20° transverse pressure angle

圖 / Fig. 1

圖 / Fig. 2

圖 / Fig. 3

軟材 / soft		
C45, 1.0503	GG20 0.6020	工程塑料 POM Plastic POM
精度等級 Gearing grade	精度等級 Gearing grade	精度等級 Gearing grade
8 e 25	8 e 26	9 bc 26

鋼鐵 Steel	訂貨號 Order code		圖 Fig.	齒數 N° of teeth z	d	d _k	d ₁	d _N	d ₃	s	鋼鐵	鑄鐵	工程塑料
	鑄鐵 Grey cast iron	工程塑料 Plastic									kg Steel	kg Grey cast iron	g Plastic
21 15 012	-	22 15 012	1	12	18,0	21,0	6	14	-	-	0,03	-	5,5
21 15 013	-	22 15 013	1	13	19,5	22,5	6	14	-	-	0,03	-	5,5
21 15 014	-	22 15 014	1	14	21,0	24,0	6	16	-	-	0,04	-	7,0
21 15 015	-	22 15 015	1	15	22,5	25,5	6	18	-	-	0,05	-	9,0
21 15 016	-	22 15 016	1	16	24,0	27,0	6	18	-	-	0,07	-	12,5
21 15 017	-	22 15 017	1	17	25,5	28,5	9	20	-	-	0,08	-	14,5
21 15 018	-	22 15 018	1	18	27,0	30,0	9	20	-	-	0,09	-	16,0
21 15 019	-	22 15 019	1	19	28,5	31,5	9	20	-	-	0,10	-	18,0
21 15 020	-	22 15 020	1	20	30,0	33,0	9	25	-	-	0,13	-	23,5
21 15 021	-	22 15 021	1	21	31,5	34,5	9	25	-	-	0,14	-	25,5
21 15 022	-	22 15 022	1	22	33,0	36,0	9	25	-	-	0,15	-	27,0
21 15 023	-	22 15 023	1	23	34,5	37,5	9	25	-	-	0,16	-	29,0
21 15 024	-	22 15 024	1	24	36,0	39,0	9	25	-	-	0,17	-	31,0
21 15 025	-	22 15 025	1	25	37,5	40,5	9	25	-	-	0,18	-	32,5
21 15 030	-	22 15 030	1	30	45,0	48,0	9	30	-	-	0,23	-	42,0
21 15 035	-	22 15 035	1	35	52,5	55,5	9	40	-	-	0,40	-	49,0
21 15 038	-	22 15 038	1	38	57,0	60,0	9	40	-	-	0,40	-	73,0
21 15 040	-	22 15 040	1	40	60,0	63,0	9	40	-	-	0,46	-	83,5
21 15 045	-	22 15 045	1	45	67,5	70,5	12	50	-	-	0,61	-	111,0
21 15 048	-	22 15 048	1	48	72,0	75,0	12	50	-	-	0,70	-	127,0
21 15 050	-	22 15 050	1	50	75,0	78,0	12	50	-	-	0,75	-	136,0
21 15 057	-	22 15 057	1	57	85,5	88,5	12	60	-	-	1,00	-	182,0
21 15 060	-	22 15 060	1	60	90,0	93,0	12	60	-	-	1,16	-	211,0
23 15 076	-	-	2	76	114,0	117,0	16	-	-	-	1,40	-	-
23 15 080	-	-	2	80	120,0	123,0	16	-	-	-	1,50	-	-
23 15 595	-	-	2	95	142,5	145,5	20	-	-	-	2,10	-	-
-	23 15 095	-	3	95	142,5	145,5	16	70	114	6,0	-	2,00	-
-	23 15 100	-	3	100	150,0	153,0	16	70	122	6,0	-	2,30	-
-	23 15 114	-	3	114	171,0	174,0	16	70	146	6,5	-	2,50	-

可以很快進行追加工 (打孔，開鍵槽，攻絲等)。
Further finishing (turning bores, keywaying, threading, etc.) is possible within short time.



直齒類，銑削加工齒，20° 壓力角

Straight tooth system, milled teeth, 20° transverse pressure angle



圖 / Fig. 1



圖 / Fig. 2

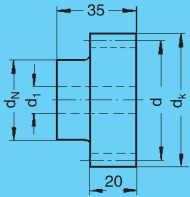

圖 / Fig. 3

軟材 / soft		
C45, 1.0503	GG20 0.6020	工程塑料 POM Plastic POM
精度等級 Gearing grade	精度等級 Gearing grade	精度等級 Gearing grade
8 e 25	8 e 26	9 bc 26

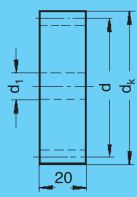
鋼鐵 Steel	訂貨號 Order code		圖 Fig.	齒數 N° of teeth z	d	dk	d1	dN	d3	s	kg	kg	g
	鑄鐵 Grey cast iron	工程塑料 Plastic									鋼鐵 Steel	鑄鐵 Grey cast iron	工程塑料 Plastic
21 20 012	-	22 20 012	1	12	24,0	28,0	9	18,0	-	-	0,07	-	15
21 20 013	-	22 20 013	1	13	26,0	30,0	9	19,0	-	-	0,12	-	18
21 20 014	-	22 20 014	1	14	28,0	32,0	9	19,0	-	-	0,14	-	20
21 20 015	-	22 20 015	1	15	30,0	34,0	9	24,5	-	-	0,15	-	21
21 20 016	-	22 20 016	1	16	32,0	36,0	9	25,0	-	-	0,17	-	23
21 20 017	-	22 20 017	1	17	34,0	38,0	9	25,0	-	-	0,18	-	32
21 20 018	-	22 20 018	1	18	36,0	40,0	9	25,0	-	-	0,19	-	36
21 20 019	-	22 20 019	1	19	38,0	42,0	9	25,0	-	-	0,20	-	39
21 20 020	-	22 20 020	1	20	40,0	44,0	9	30,0	-	-	0,22	-	47
21 20 021	-	22 20 021	1	21	42,0	46,0	9	30,0	-	-	0,26	-	51
21 20 022	-	22 20 022	1	22	44,0	48,0	9	30,0	-	-	0,27	-	55
21 20 023	-	22 20 023	1	23	46,0	50,0	9	30,0	-	-	0,28	-	59
21 20 024	-	22 20 024	1	24	48,0	52,0	12	35,0	-	-	0,36	-	65
21 20 025	-	22 20 025	1	25	50,0	54,0	12	35,0	-	-	0,39	-	70
21 20 028	-	-	1	28	56,0	60,0	12	40,0	-	-	0,45	-	-
21 20 030	-	22 20 030	1	30	60,0	64,0	12	40,0	-	-	0,50	-	105
21 20 032	-	-	1	32	64,0	68,0	12	40,0	-	-	0,60	-	-
21 20 035	-	-	1	35	70,0	74,0	12	50,0	-	-	0,67	-	-
21 20 036	-	-	1	36	72,0	76,0	12	50,0	-	-	0,85	-	-
21 20 038	-	-	1	38	76,0	80,0	12	50,0	-	-	0,90	-	-
21 20 040	-	-	1	40	80,0	84,0	12	50,0	-	-	0,95	-	-
21 20 045	-	-	1	45	90,0	94,0	12	60,0	-	-	1,25	-	-
21 20 048	-	-	1	48	96,0	100,0	15	70,0	-	-	1,50	-	-
21 20 050	-	-	1	50	100,0	104,0	15	70,0	-	-	1,60	-	-
21 20 056	-	-	1	56	112,0	116,0	15	70,0	-	-	1,90	-	-
21 20 057	-	-	1	57	114,0	118,0	15	70,0	-	-	2,00	-	-
21 20 060	-	-	1	60	120,0	124,0	15	70,0	-	-	2,40	-	-
23 20 576	-	-	2	76	152,0	156,0	20	-	-	-	2,80	-	-
23 20 580	-	-	2	80	160,0	164,0	20	-	-	-	3,10	-	-
23 20 595	-	-	2	95	190,0	194,0	20	-	-	-	4,40	-	-
-	23 20 076	-	3	76	152,0	156,0	16	70,0	126	7,5	-	1,80	-
-	23 20 080	-	3	80	160,0	164,0	16	70,0	134	7,5	-	1,90	-
-	23 20 095	-	3	95	190,0	194,0	16	80,0	164	7,5	-	2,20	-
-	23 20 100	-	3	100	200,0	204,0	16	80,0	174	7,5	-	2,50	-
-	23 20 114	-	3	114	228,0	232,0	16	80,0	200	7,5	-	2,70	-

可以很快進行追加工（打孔，開鍵槽，攻絲等）。

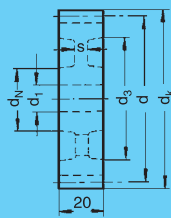
Further finishing (turning bores, keywaying, threading, etc.) is possible within short time.





直齒類，銑削加工齒，20° 壓力角
Straight tooth system, milled teeth, 20° transverse pressure angle

圖 / Fig. 1

圖 / Fig. 2

圖 / Fig. 3

軟材 / soft		
C45, 1.0503	GG20 0.6020	工程塑料 POM Plastic POM
精度等級 Gearing grade	精度等級 Gearing grade	精度等級 Gearing grade
8 e 25	8 e 26	9 bc 26

鋼鐵 Steel	訂貨號 Order code		圖 Fig.	齒數 N° of teeth z	d	d _k	d ₁	d _N	d ₃	s	kg		
	鑄鐵 Grey cast iron	工程塑料 Plastic									鋼鐵 Steel	鑄鐵 Grey cast iron	工程塑料 Plastic
21 25 012	-	22 25 012	1	12	30,0	35,0	9	20,0	-	-	0,16	-	29
21 25 013	-	22 25 013	1	13	32,5	37,5	9	20,0	-	-	0,18	-	32
21 25 014	-	22 25 014	1	14	35,0	40,0	9	25,0	-	-	0,22	-	40
21 25 015	-	22 25 015	1	15	37,5	42,5	9	25,0	-	-	0,25	-	45
21 25 016	-	22 25 016	1	16	40,0	45,0	9	30,0	-	-	0,31	-	56
21 25 017	-	22 25 017	1	17	42,5	47,5	9	30,0	-	-	0,35	-	63
21 25 018	-	22 25 018	1	18	45,0	50,0	9	35,0	-	-	0,41	-	74
21 25 019	-	22 25 019	1	19	47,5	52,5	12	35,0	-	-	0,43	-	78
21 25 020	-	22 25 020	1	20	50,0	55,0	12	35,0	-	-	0,47	-	85
21 25 021	-	22 25 021	1	21	52,5	57,5	12	35,0	-	-	0,50	-	90
21 25 022	-	22 25 022	1	22	55,0	60,0	12	40,0	-	-	0,53	-	96
21 25 023	-	22 25 023	1	23	57,5	62,5	12	40,0	-	-	0,62	-	112
21 25 024	-	22 25 024	1	24	60,0	65,0	12	40,0	-	-	0,66	-	120
21 25 025	-	22 25 025	1	25	62,5	67,5	12	45,0	-	-	0,75	-	136
21 25 030	-	22 25 030	1	30	75,0	80,0	12	50,0	-	-	0,97	-	176
21 25 035	-	-	1	35	87,5	92,5	12	60,0	-	-	1,49	-	-
21 25 038	-	-	1	38	95,0	100,0	12	60,0	-	-	1,72	-	-
21 25 040	-	-	1	40	100,0	105,0	12	70,0	-	-	1,84	-	-
21 25 045	-	-	1	45	112,5	117,5	15	70,0	-	-	2,36	-	-
21 25 048	-	-	1	48	120,0	125,0	15	80,0	-	-	2,75	-	-
21 25 050	-	-	1	50	125,0	130,0	15	80,0	-	-	2,94	-	-
21 25 057	-	-	1	57	142,5	147,5	15	90,0	-	-	3,67	-	-
21 25 060	-	-	1	60	150,0	155,0	15	90,0	-	-	4,00	-	-
23 25 576	-	-	2	76	190,0	195,0	20	-	-	-	5,50	-	-
23 25 580	-	-	2	80	200,0	205,0	25	-	-	-	6,10	-	-
23 25 595	-	-	2	95	237,5	242,5	25	-	-	-	8,60	-	-
-	23 25 076	-	3	76	190,0	195,0	20	80,0	160	8,0	-	2,50	-
-	23 25 080	-	3	80	200,0	205,0	20	80,0	166	8,0	-	2,70	-
-	23 25 095	-	3	95	237,5	242,5	20	90,0	198	8,0	-	3,70	-
-	23 25 100	-	3	100	250,0	255,0	20	90,0	210	8,0	-	4,40	-
-	23 25 114	-	3	114	285,0	290,0	20	90,0	240	8,0	-	5,10	-

可以很快進行追加工 (打孔，開鍵槽，攻絲等)。
Further finishing (turning bores, keywaying, threading, etc.) is possible within short time.



直齒類，銑削加工齒，20° 壓力角
Straight tooth system, milled teeth, 20° transverse pressure angle

圖 / Fig. 1

圖 / Fig. 2

圖 / Fig. 3

軟材 / soft		
C45, 1.0503	GG20 0.6020	工程塑料 POM Plastic POM
精度等級 Gearing grade	精度等級 Gearing grade	精度等級 Gearing grade
8 e 25	8 e 26	9 bc 26

鋼鐵 Steel	訂貨號 Order code		圖 Fig.	齒數 N° of teeth z	d	dk	d1	dN	d3	s	kg		
	鑄鐵 Grey cast iron	工程塑料 Plastic									鋼鐵 Steel	鑄鐵 Grey cast iron	工程塑料 Plastic
21 30 012	-	22 30 012	1	12	36	42	14	25	-	-	0,25	-	45
21 30 013	-	22 30 013	1	13	39	45	14	25	-	-	0,30	-	54
21 30 014	-	22 30 014	1	14	42	48	14	25	-	-	0,34	-	61
21 30 015	-	22 30 015	1	15	45	51	14	35	-	-	0,41	-	74
21 30 016	-	22 30 016	1	16	48	54	14	35	-	-	0,51	-	92
21 30 017	-	22 30 017	1	17	51	57	14	42	-	-	0,67	-	121
21 30 018	-	22 30 018	1	18	54	60	14	45	-	-	0,70	-	127
21 30 019	-	22 30 019	1	19	57	63	14	45	-	-	0,75	-	136
21 30 020	-	22 30 020	1	20	60	66	14	45	-	-	0,82	-	149
21 30 021	-	22 30 021	1	21	63	69	14	45	-	-	0,89	-	161
21 30 022	-	22 30 022	1	22	66	72	14	50	-	-	1,05	-	190
21 30 023	-	22 30 023	1	23	69	75	14	50	-	-	1,10	-	200
21 30 024	-	22 30 024	1	24	72	78	14	50	-	-	1,20	-	218
21 30 025	-	22 30 025	1	25	75	81	14	60	-	-	1,35	-	245
21 30 027	-	-	1	27	81	87	14	60	-	-	1,60	-	-
21 30 028	-	-	1	28	84	90	14	60	-	-	1,70	-	-
21 30 030	-	-	1	30	90	96	14	60	-	-	1,80	-	-
21 30 032	-	-	1	32	96	102	14	60	-	-	2,00	-	-
21 30 035	-	-	1	35	105	111	14	80	-	-	2,70	-	-
21 30 036	-	-	1	36	108	114	14	80	-	-	2,80	-	-
21 30 038	-	-	1	38	114	120	14	80	-	-	3,00	-	-
21 30 040	-	-	1	40	120	126	14	80	-	-	3,30	-	-
23 30 545	-	-	2	45	135	141	20	-	-	-	3,30	-	-
23 30 548	-	-	2	48	144	150	20	-	-	-	3,80	-	-
23 30 550	-	-	2	50	150	156	25	-	-	-	4,10	-	-
23 30 552	-	-	2	52	156	162	25	-	-	-	4,50	-	-
23 30 556	-	-	2	56	168	174	25	-	-	-	5,20	-	-
23 30 560	-	-	2	60	180	186	25	-	-	-	6,00	-	-
23 30 576	-	-	2	76	228	234	25	-	-	-	9,60	-	-
23 30 580	-	-	2	80	240	246	25	-	-	-	10,60	-	-
23 30 595	-	-	2	95	285	291	25	-	-	-	15,00	-	-
-	23 30 050	-	3	50	150	156	25	80	122	9,5	-	2,50	-
-	23 30 060	-	3	60	180	186	25	80	152	9,5	-	3,20	-
-	23 30 080	-	3	80	240	246	25	90	212	9,5	-	4,50	-
-	23 30 095	-	3	95	285	291	25	100	254	10,5	-	6,40	-
-	23 30 100	-	3	100	300	306	25	100	268	12,5	-	7,60	-
-	23 30 114	-	3	114	342	348	25	100	310	12,5	-	9,00	-

可以很快進行追加加工（打孔，開鍵槽，攻絲等）。
Further finishing (turning bores, keywaying, threading, etc.) is possible within short time.





直齒類，銑削加工齒，20° 壓力角
Straight tooth system, milled teeth, 20° transverse pressure angle

圖 / Fig. 1

圖 / Fig. 2

圖 / Fig. 3

軟材 / soft

C45 1.0503	GG 20 0.6020
精度等級 Gearing grade	精度等級 Gearing grade
8 e 25	8 e 26

鋼鐵 Steel	訂貨號 Order code		圖 Fig.	齒數 N° of teeth z	d	dk	d1	dN	d3	s	鋼材 / soft		
	鑄鐵 Grey cast iron	工程塑料 Plastic									kg Steel	kg 鑄鐵 Grey cast iron	g 工程塑料 Plastic
21 40 012	-	-	1	12	48	56	16	35	-	-	0,58	-	-
21 40 013	-	-	1	13	52	60	16	35	-	-	0,72	-	-
21 40 014	-	-	1	14	56	64	16	45	-	-	0,90	-	-
21 40 015	-	-	1	15	60	68	16	45	-	-	1,00	-	-
21 40 016	-	-	1	16	64	72	16	45	-	-	1,10	-	-
21 40 017	-	-	1	17	68	76	16	50	-	-	1,30	-	-
21 40 018	-	-	1	18	72	80	16	50	-	-	1,40	-	-
21 40 019	-	-	1	19	76	84	16	60	-	-	1,70	-	-
21 40 020	-	-	1	20	80	88	16	60	-	-	1,80	-	-
21 40 021	-	-	1	21	84	92	16	70	-	-	2,20	-	-
21 40 022	-	-	1	22	88	96	16	70	-	-	2,50	-	-
21 40 023	-	-	1	23	92	100	16	75	-	-	2,60	-	-
21 40 024	-	-	1	24	96	104	16	75	-	-	2,75	-	-
21 40 025	-	-	1	25	100	108	16	75	-	-	2,90	-	-
21 40 030	-	-	1	30	120	128	16	75	-	-	4,00	-	-
23 40 538	-	-	2	38	152	160	25	-	-	-	5,70	-	-
23 40 540	-	-	2	40	160	168	25	-	-	-	6,30	-	-
23 40 545	-	-	2	45	180	188	25	-	-	-	8,00	-	-
23 40 548	-	-	2	48	192	200	25	-	-	-	9,00	-	-
23 40 550	-	-	2	50	200	208	25	-	-	-	9,80	-	-
23 40 552	-	-	2	52	208	216	25	-	-	-	10,60	-	-
23 40 556	-	-	2	56	224	232	25	-	-	-	12,30	-	-
23 40 560	-	-	2	60	240	248	25	-	-	-	14,20	-	-
23 40 576	-	-	2	76	304	312	25	-	-	-	22,70	-	-
23 40 580	-	-	2	80	320	328	25	-	-	-	25,20	-	-
23 40 595	-	-	2	95	380	388	25	-	-	-	35,60	-	-
-	23 40 038	-	3	38	152	160	25	80	116	12,5	-	3,90	-
-	23 40 040	-	3	40	160	168	25	80	124	12,5	-	4,20	-
-	23 40 050	-	3	50	200	208	25	90	164	12,5	-	5,60	-
-	23 40 060	-	3	60	240	248	25	90	200	12,5	-	7,30	-
-	23 40 076	-	3	76	304	312	25	100	264	12,5	-	9,50	-
-	23 40 080	-	3	80	320	328	25	100	280	13,5	-	10,70	-
-	23 40 095	-	3	95	380	388	25	110	340	13,5	-	14,30	-
-	23 40 100	-	3	100	400	408	25	110	360	13,5	-	15,50	-
-	23 40 114	-	3	114	456	464	25	110	415	13,5	-	19,70	-

可以很快進行追加加工（打孔，開鍵槽，攻絲等）。
Further finishing (turning bores, keywaying, threading, etc.) is possible within short time.



直齒類，銑削加工齒，20° 壓力角
Straight tooth system, milled teeth, 20° transverse pressure angle

圖 / Fig. 1

圖 / Fig. 2

圖 / Fig. 3

軟材 / soft	
C45 1.0503	GG 20 0.6020
精度等級 Gearing grade	精度等級 Gearing grade
8 e 25	8 e 26

鋼鐵 Steel	訂貨號 Order code 鑄鐵 Grey cast iron	工程塑料 Plastic	圖 Fig.	齒數 N° of teeth z	d	dk	d1	dN	d3	s	kg		
											鋼鐵 Steel	鑄鐵 Grey cast iron	工程塑料 Plastic
21 50 012	-	-	1	12	60	70	20	45	-	-	1,20	-	-
21 50 013	-	-	1	13	65	75	20	45	-	-	1,38	-	-
21 50 014	-	-	1	14	70	80	20	55	-	-	1,78	-	-
21 50 015	-	-	1	15	75	85	20	60	-	-	2,00	-	-
21 50 016	-	-	1	16	80	90	20	60	-	-	2,10	-	-
21 50 017	-	-	1	17	85	95	20	70	-	-	2,20	-	-
21 50 018	-	-	1	18	90	100	20	70	-	-	2,58	-	-
21 50 019	-	-	1	19	95	105	20	70	-	-	2,80	-	-
21 50 020	-	-	1	20	100	110	20	70	-	-	3,10	-	-
21 50 021	-	-	1	21	105	115	20	70	-	-	3,80	-	-
21 50 022	-	-	1	22	110	120	20	80	-	-	4,30	-	-
21 50 023	-	-	1	23	115	125	20	80	-	-	4,70	-	-
21 50 024	-	-	1	24	120	130	20	80	-	-	5,00	-	-
21 50 025	-	-	1	25	125	135	20	80	-	-	5,40	-	-
21 50 030	-	-	1	30	150	160	20	90	-	-	7,70	-	-
23 50 536	-	-	2	36	180	190	30	-	-	-	9,90	-	-
23 50 538	-	-	2	38	190	200	30	-	-	-	11,10	-	-
23 50 540	-	-	2	40	200	210	30	-	-	-	12,30	-	-
23 50 545	-	-	2	45	225	235	30	-	-	-	15,60	-	-
23 50 548	-	-	2	48	240	250	30	-	-	-	17,70	-	-
23 50 550	-	-	2	50	250	260	30	-	-	-	19,20	-	-
23 50 552	-	-	2	52	260	270	30	-	-	-	20,80	-	-
23 50 556	-	-	2	56	280	290	30	-	-	-	24,10	-	-
23 50 560	-	-	2	60	300	310	30	-	-	-	27,70	-	-
23 50 576	-	-	2	76	380	390	30	-	-	-	44,40	-	-
23 50 580	-	-	2	80	400	410	30	-	-	-	49,20	-	-
23 50 595	-	-	2	95	475	485	30	-	-	-	69,50	-	-
-	23 50 038	-	3	38	190	200	40	100	160	14	-	6,80	-
-	23 50 040	-	3	40	200	210	40	100	165	14	-	7,40	-
-	23 50 050	-	3	50	250	260	40	100	215	16	-	9,60	-
-	23 50 060	-	3	60	300	310	40	100	260	16	-	12,60	-
-	23 50 076	-	3	76	380	390	40	120	340	16	-	18,20	-
-	23 50 080	-	3	80	400	410	40	130	360	16	-	19,00	-
-	23 50 095	-	3	95	475	485	40	130	430	16	-	26,00	-
-	23 50 100	-	3	100	500	510	40	180	450	22	-	30,70	-
-	23 50 114	-	3	114	570	580	40	180	510	22	-	38,70	-
-	23 50 150	-	3	150	750	760	40	180	700	22	-	58,00	-

可以很快進行追加加工（打孔，開鍵槽，攻絲等）。
Further finishing (turning bores, keywaying, threading, etc.) is possible within short time.





模數 6, 直齒類, 銑削加工齒, 20° 壓力角
Module 6, straight tooth system, milled teeth, 20° transverse pressure angle

圖 / Fig. 1

圖 / Fig. 2

圖 / Fig. 3

軟材 / soft	
C45 1.0503	GG 20 0.6020
精度等級 Gearing grade 8 e 25	精度等級 Gearing grade 8 e 26

鋼鐵 Steel	訂貨號 Order code	工程塑料 Plastic	圖 Fig.	齒數 N° of teeth z	d	d _k	d ₁	d _N	d ₃	s	kg	kg	g
	鑄鐵 Grey cast iron										鋼鐵 Steel	鑄鐵 Grey cast iron	工程塑料 Plastic
–	21 60 015	–	1	15	90	102	20	60	–	–	3,20	–	–
–	21 60 018	–	1	18	108	120	20	80	–	–	4,80	–	–
–	21 60 019	–	1	19	114	126	20	80	–	–	5,40	–	–
–	21 60 020	–	1	20	120	132	20	90	–	–	6,00	–	–
–	21 60 021	–	1	21	126	138	20	90	–	–	6,70	–	–
–	21 60 022	–	1	22	132	144	20	100	–	–	7,40	–	–
–	21 60 025	–	1	25	150	162	20	110	–	–	9,60	–	–
–	23 60 530	–	2	30	180	192	30	–	–	–	11,90	–	–
–	23 60 536	–	2	36	216	228	30	–	–	–	17,20	–	–
–	23 60 538	–	2	38	228	240	30	–	–	–	19,20	–	–
–	23 60 540	–	2	40	240	252	30	–	–	–	21,20	–	–
–	23 60 030	–	3	30	180	192	40	100	132	20	–	8,80	–
–	23 60 038	–	3	38	228	240	40	100	180	20	–	12,10	–
–	23 60 050	–	3	50	300	312	40	120	252	20	–	19,00	–
–	23 60 076	–	3	76	456	468	40	130	408	20	–	36,40	–

可以很快進行追加工 (打孔, 開鍵槽, 攻絲等)。
Further finishing (turning bores, keywaying, threading, etc.) is possible within short time.

模數 8 至 12, 直齒類, 銑削加工齒, 20° 壓力角
Module 8 to 12, straight tooth system, milled teeth, 20° transverse pressure angle

圖 / Fig. 1

圖 / Fig. 2

圖 / Fig. 3

軟材 / soft	
Ck45 1.0503	
精度等級 Gearing grade 8 e 25	

訂貨號 Order code	圖 Fig.	齒數 N° of teeth	d	d _k	d ₁	d _N	d ₃	s	kg
模數 / Module 8									
21 80 015	1	15	120	136	40	90	–	–	7,70
21 80 018	1	18	144	160	40	100	–	–	9,90
21 80 020	1	20	160	176	40	120	–	–	14,80
21 80 024	1	24	192	208	40	150	–	–	22,00
21 80 025	1	25	200	216	40	150	–	–	23,80
21 80 030	1	30	240	256	40	190	–	–	32,00
模數 / Module 10*									
21 11 020	2	20	200	220	40	150	–	–	35,00
模數 / Module 12*									
21 12 020	3	20	240	264	40	170	–	–	51,33

* 帶螺紋孔 M8 / with threads for handling

可以很快進行追加工 (打孔, 開鍵槽, 攻絲等)。
Further finishing (turning bores, keywaying, threading, etc.) is possible within short time.



直齒類, 銑削加工齒, 20° 壓力角

Straight tooth system, milled teeth, 20° transverse pressure angle

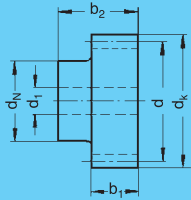

軟材 / soft
X 8 CrNiS 18 9 1.4305
精度等級 Gearing grade
8 e 25

訂貨號 Order code	齒數 N° of teeth z	d	dk	d ₁	d _N	b ₁	b ₂	kg
模數 / Module 1								
06 10 012	12	12,0	14,0	4	10	10	16	0,01
06 10 015	15	15,0	17,0	5	12	10	16	0,02
06 10 018	18	18,0	20,0	6	15	10	16	0,03
06 10 020	20	20,0	22,0	6	15	10	16	0,04
06 10 025	25	25,0	27,0	8	20	10	16	0,05
06 10 030	30	30,0	32,0	8	25	10	18	0,08
06 10 040	40	40,0	42,0	8	25	10	18	0,12
06 10 050	50	50,0	52,0	10	30	10	20	0,20
06 10 060	60	60,0	62,0	10	40	10	22	0,30
06 10 070	70	70,0	72,0	10	40	10	22	0,40
06 10 080	80	80,0	82,0	10	50	10	22	0,55
06 10 100	100	100,0	102,0	12	60	10	22	0,85
模數 / Module 1,5								
06 15 012	12	18,0	21,0	8	15	15	25	0,03
06 15 015	15	22,5	25,5	10	18	15	25	0,05
06 15 018	18	27,0	30,0	10	22	15	25	0,08
06 15 020	20	30,0	33,0	10	25	15	25	0,10
06 15 025	25	37,5	40,5	10	25	15	30	0,17
06 15 030	30	45,0	48,0	10	30	15	30	0,26
06 15 040	40	60,0	63,0	10	40	15	30	0,50
06 15 050	50	75,0	78,0	10	50	15	30	0,73
06 15 060	60	90,0	93,0	12	60	15	30	1,10
模數 / Module 2								
06 20 212	12	24,0	28,0	10	20	20	31	0,07
06 20 215	15	30,0	34,0	12	25	20	31	0,12
06 20 218	18	36,0	40,0	12	30	20	31	0,18
06 20 220	20	40,0	44,0	12	30	20	31	0,22
06 20 225	25	50,0	54,0	12	30	20	31	0,25
06 20 230	30	60,0	64,0	12	40	20	31	0,48
06 20 240	40	80,0	84,0	12	50	20	31	0,85
06 20 250	50	100,0	104,0	12	50	20	31	1,20
06 20 260	60	120,0	124,0	12	70	20	31	1,85
模數 / Module 3								
06 30 212	12	36,0	42,0	12	25	30	40	0,21
06 30 215	15	45,0	51,0	12	35	30	40	0,38
06 30 218	18	54,0	60,0	12	45	30	40	0,60
06 30 220	20	60,0	66,0	15	45	30	40	0,68
06 30 225	25	75,0	81,0	15	50	30	40	1,05
06 30 230	30	90,0	96,0	20	50	30	40	2,70
06 30 240	40	120,0	126,0	20	70	30	45	3,50
06 30 250	50	150,0	156,0	20	80	30	45	4,20



可以很快進行追加加工 (打孔, 開鍵槽, 攻絲等)。
Further finishing (turning bores, keywaying, threading, etc.) is possible within short time.