



HTG240160L-3SW-18C10-V08

产品名称 (Product name) : 黑白点阵 COG
型 号 (Model) : HTG240160L-3SW-18C10-V08
编 号 (EDC number) : _____
日 期 (Date) : 2018-09-05

编码: QR-R-011 A/0

序号:

深圳市鑫洪泰电子科技有限公司 Shenzhen Hot Display Technology Co.,Ltd		
编制 Prepared by	审核 Checked by	核准 Approved by

Rev.	Descriptions	Date
01	Prelimiay Release	2018-09-15

Table of Content

1. Basic Specifications	3
1.1 Display Specifications	3
1.2 Mechanical Specifications	3
1.3 Circuit Diagram	3
1.4 Terminal Function	4
1.5 Product Outline	6
2. Absolute Maximum Ratings	6
3. Electrical Characteristics	6
3.1 DC Characteristics	6
3.2 LED Backlight Circuit	7
3.3 AC Characteristics	9
3.4 Reset Timing	9
4. Function specifications	10
4.1 The Parallel Interface	10
4.2 Basic Setting	11
4.3 Resetting the LCD module	11
4.4 Display Memory Map	12
4.5 Display Commands	12
4.6 Basic Operating Sequence	13
5. Inspection Standards	14
6. Handling Precautions	15
6.1 Mounting method	15
6.2 Cautions of LCD handling and cleaning	15
6.3 Caution against static charge	15
6.4 Packaging	15
6.5 Caution for operation	15
6.6 Storage	15
6.7 Safety	15

1. Bsaic Specifications

1.1 Display Specifications

- 1>LCD Display Mode : FSTN, Positive, Transflective
- 2>Viewing Angle : 6H
- 3>Driving Method : 1/160 Duty, 1/12 Bias
- 4>Backlight : White LED (3PCS)

1.2 Mechanical Specifications

- 1>Outline Dimension : 60.0 x 49.5 x 5.6mm (See attached Outline Drawing for Details)

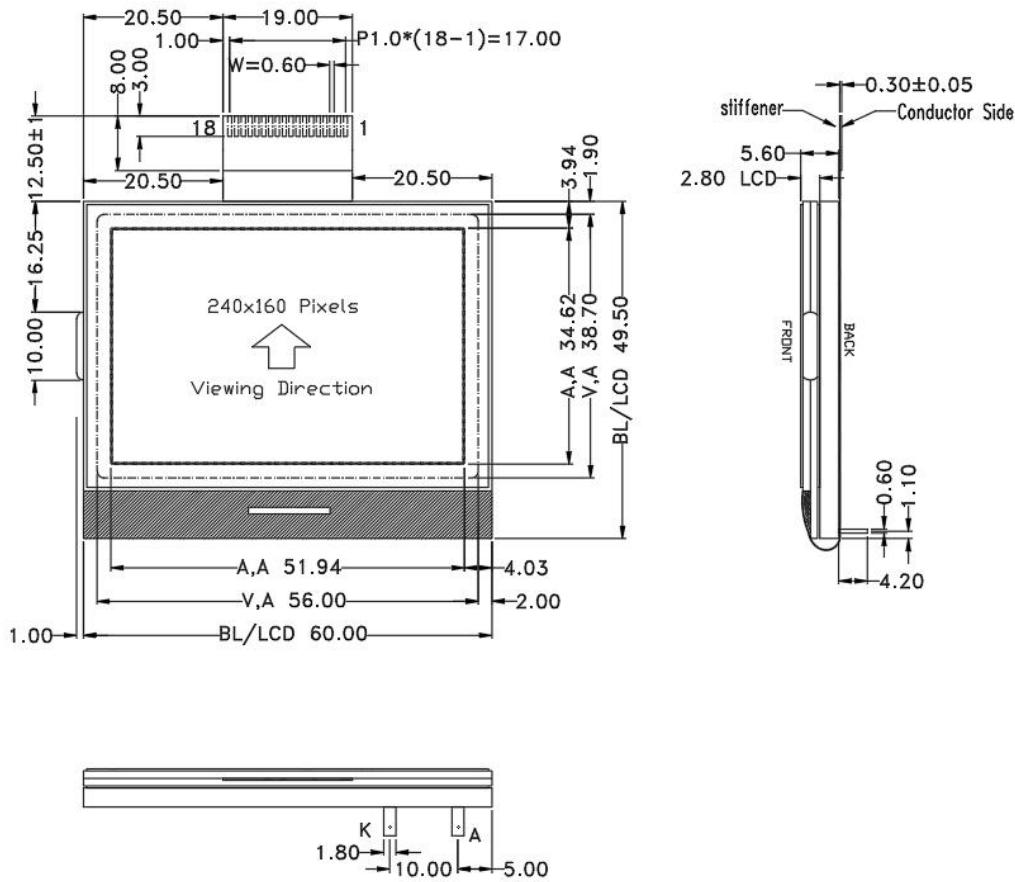

1.3 Circuit Diagram

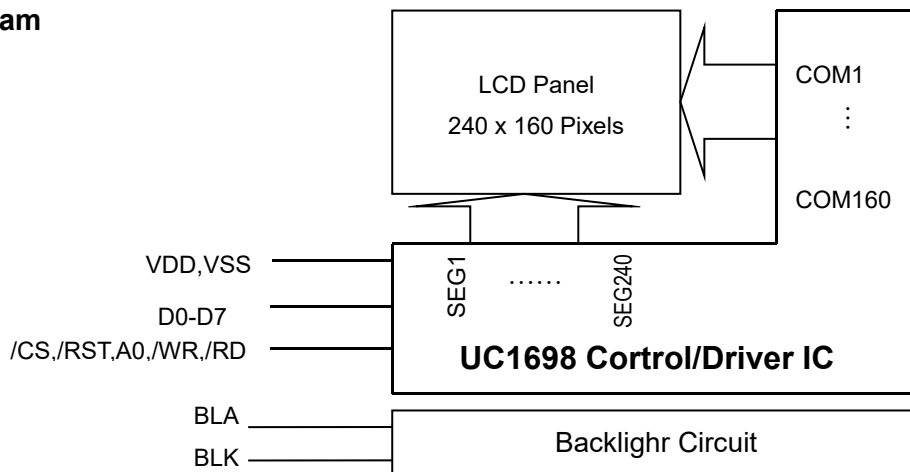

1.4 Terminal Function

Pin No.	Pin Name	Function
1-8	DB7-DB0	Data Bus
9	/RST	Reste, L->H
10	/WR	Write Data/Command Clock
11	/RD	Read Data Clock
12	A0	Data/Command control
13	/CS	Chip selection input
14	VSS	Negative power supply,0V
15	VDD	Power supply voltage (+3.3V)
16~18	NC	

1.5 Product Outline

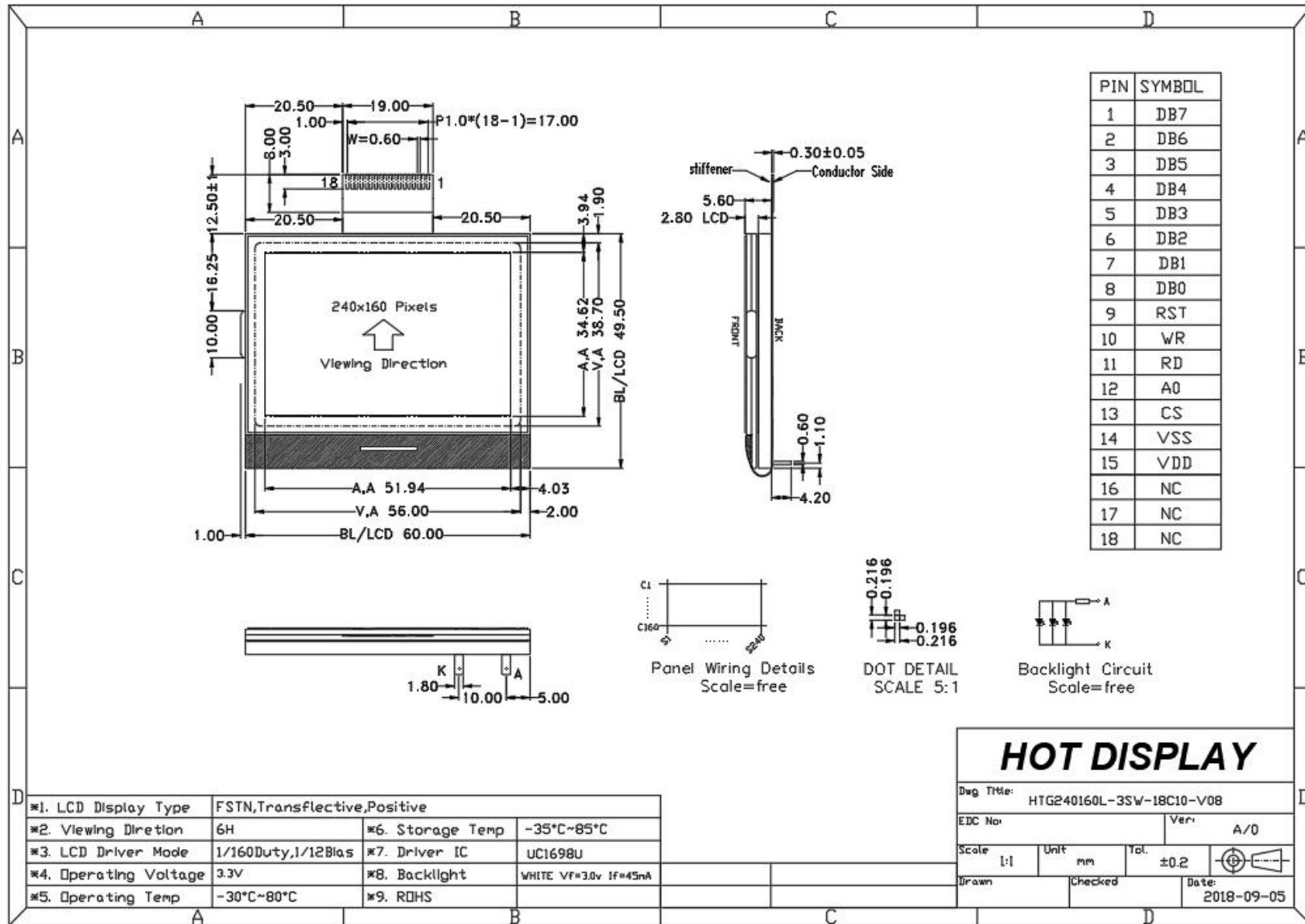

2. Absolute Maximum Ratings

Items	Symbol	MIN.	MAX.	Unit	Condition
Supply Voltage	V _{DD}	-0.3	+3.6	V	V _{SS} = 0V
	V _{DD2}	-0.3	+3.6	V	V _{SS} = 0V
Input Voltage	V _{IN}	-0.3	V _{DD} +0.3	V	V _{SS} = 0V
Operating Temperature	T _{OP}	-30	+80	°C	No Condensation
Storage Temperature	T _{st}	-35	+85	°C	No Condensation

3. Electrical Characteristics

3.1 DC Characteristics

(V_{SS} = 0V, V_{DD} = 2.4 to 3.6V, T_a = -40~85°C)

Items	Symbol	MIN.	TYP.	MAX.	Unit	Condition
Operating Voltage(1)	V _{DD}	3.0	-	3.3	V	
Driver Voltage	V _{LCD}	-0.3	-	19.0	V	
Input High Voltage	V _{IH}	0.8 x V _{DD}	-	V _{DD}	V	
Input Low Voltage	V _{IL}	V _{SS}	-	0.2 x V _{DD}	V	
Output High Voltage	V _{OH}	0.8 x V _{DD}	-	V _{DD}	V	I _{OH} = -0.5mA
Output Low Voltage	V _{OL}	V _{SS}	-	0.2 x V _{DD}	V	I _{OL} = 0.5mA
Input Leakage Current	I _{LI}	-	-	1.5	μA	V _{IN} = V _{DD} or V _{SS}

3.2 AC Characteristics

Read/Write Characteristics (8080-series MPU)

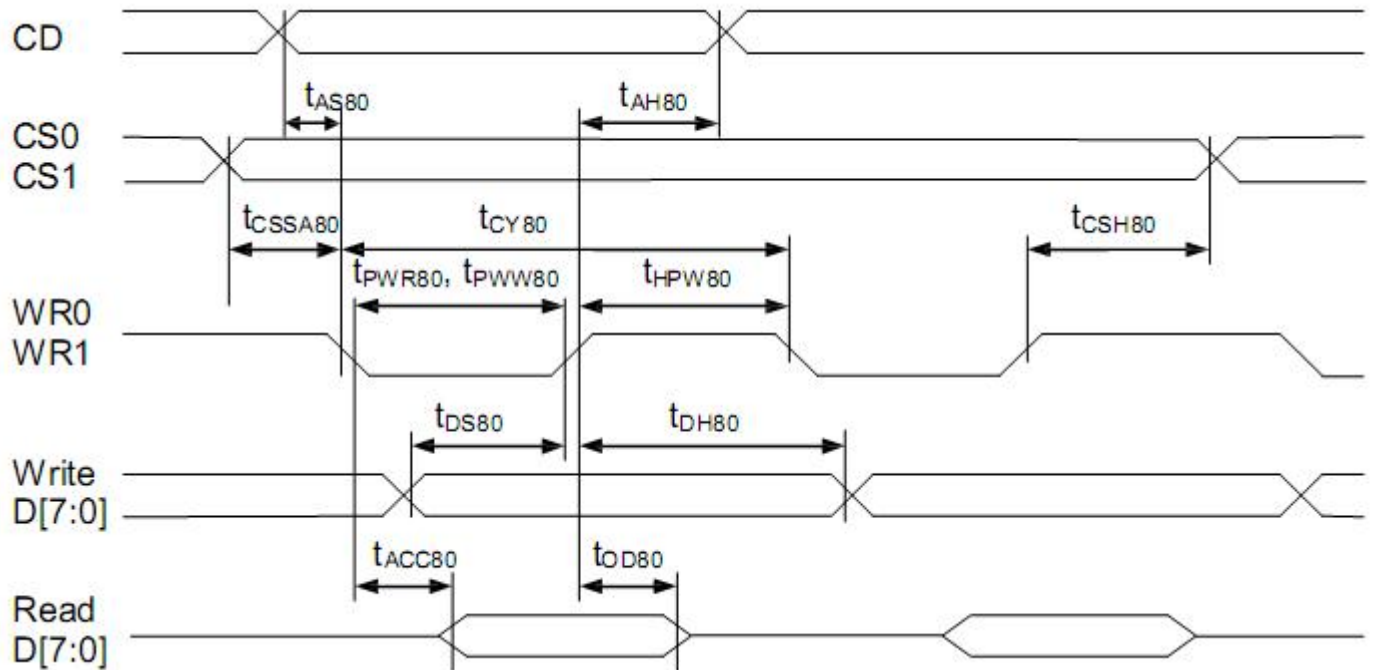

(2.5V \leq V_{DD} $<$ 3.3V, $T_a = -30$ to $+85^\circ\text{C}$)

Symbol	Signal	Description	Condition	Min.	Max.	Units
t_{AS80}	CD	Address setup time		0	–	nS
t_{AH80}		Address hold time		0	–	nS
t_{CY80}		System cycle time			–	nS
		16-bit bus (read)		170		
		(write)		130		
		8-bit bus (read)		100		
		(write)		80		
t_{PWR80}	WR1	Pulse width 16-bit (read)		85	–	nS
		8-bit		50		
t_{PWW80}	WR0	Pulse width 16-bit (write)		65	–	nS
		8-bit		40		
t_{HPW80}	WR0, WR1	High pulse width			–	nS
		16-bit bus (read)		85		
		(write)		65		
		8-bit bus (read)		50		
		(write)		40		
t_{DS80}	D0~D15	Data setup time		30	–	nS
t_{DH80}		Data hold time		0		
t_{ACC80}		Read access time	$C_L = 100\text{pF}$	–	60	nS
t_{OD80}		Output disable time		15	30	
T_{CSA80}	CS1/CS0	Chip select setup time		5		nS
t_{CSH80}				5		

Read/Write Characteristics (6800-series MPU)

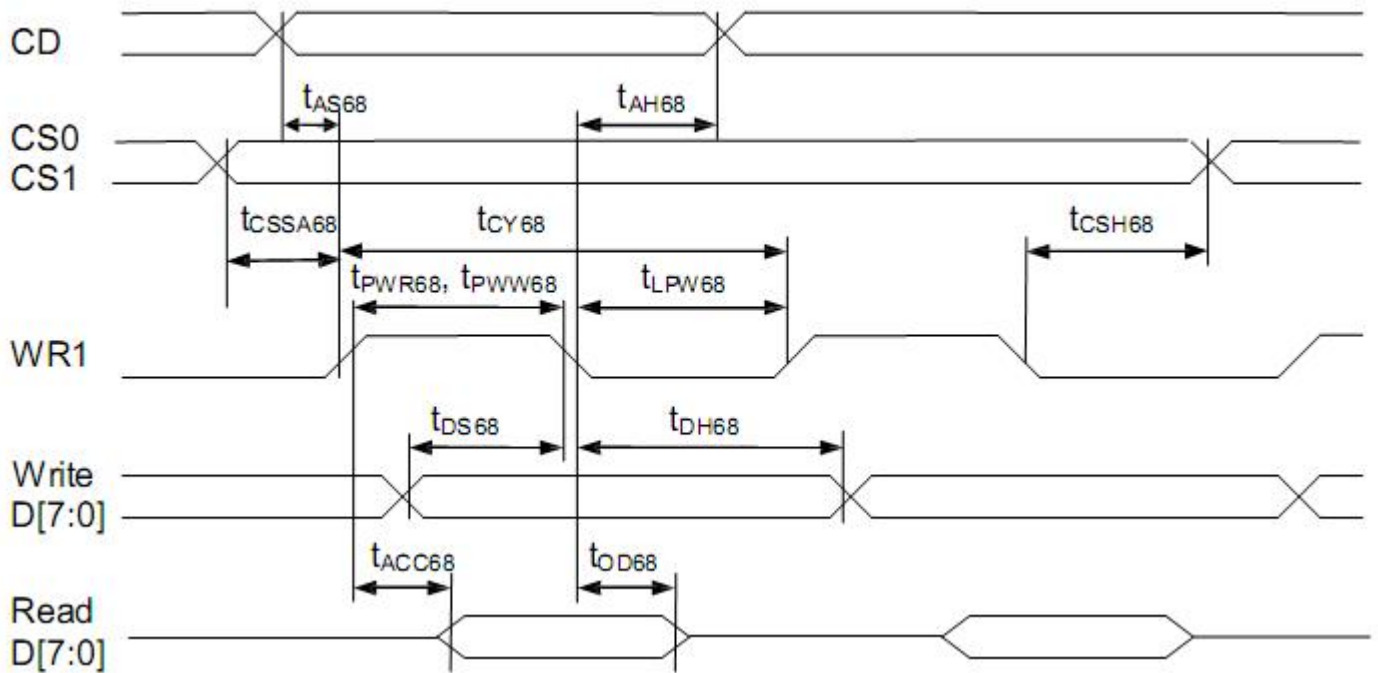

(2.5V $\leq V_{DD} < 3.3V$, $T_a = -30$ to $+85^\circ C$)

Symbol	Signal	Description	Condition	Min.	Max.	Units
t_{AS68} t_{AH68}	CD	Address setup time Address hold time		0 0	-	nS
t_{CY68}		System cycle time 16-bit bus (read) (write) 8-bit bus (read) (write)		170 130 100 80	-	nS
t_{PWR68}	WR1	Pulse width 16-bit (read) 8-bit		85 50	-	nS
t_{PWW68}		Pulse width 16-bit (write) 8-bit		65 40	-	nS
t_{LPW68}		Low pulse width 16-bit bus (read) (write) 8-bit bus (read) (write)		85 65 50 40	-	nS
t_{DS68} t_{DH68}	D0~D7	Data setup time Data hold time		30 0	-	nS
t_{ACC68} t_{OD68}		Read access time Output disable time	$C_L = 100pF$	- 15	60 30	nS
t_{CSSA68} t_{CSH68}	CS1/CS0	Chip select setup time		5 5		nS

3.3 Resret Timing

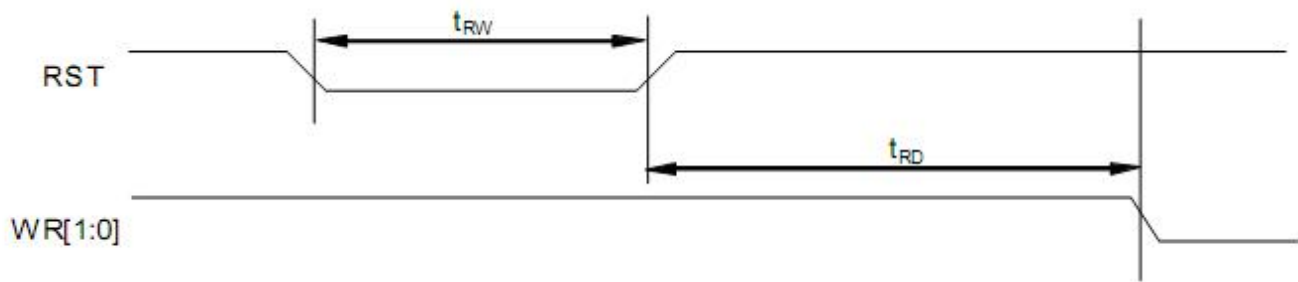

(1.65V \leq V_{DD} < 3.3V, $T_a = -30$ to $+85^\circ\text{C}$)

Symbol	Signal	Description	Condition	Min.	Max.	Units
t_{RW}	RST	Reset low pulse width		3	–	μS
t_{RD}	RST, WR	Reset to WR pulse delay		10	–	mS

4. Function specifications

4.1 Display data format

16 bits of input data are stored to 16 RAM bits directly.

Data Write Sequence (8-bit)	D[7:0]								
1 st Write Data Cycle	R4	R3	R2	R1	R0	G5	G4	G3	
2 nd Write Data Cycle	G2	G1	G0	B4	B3	B2	B1	B0	

For Example

Black and white mode:

RGB=SEG1/SEG2/SEG3.

R[4:0]= Fixed Value[0x1F] ->SEG1 Show,

G[5:0]= Fixed Value[0x3F] ->SEG2 Show,

B[4:0]= Fixed Value[0x1F] ->SEG3 Show,

Grayscale mode:

R[4:0]= Range[0-31] ->SEG1 Show,

G[5:0]= Range[0-63] ->SEG2 Show,

B[4:0]= Range[0-31] ->SEG3 Show,

Note:Write three points must be continuous,SEG1/SEG2/SEG3 Share a single address

(注：必须连续写三个点,因为三点共用一个地址,根据设置,写完后,地址会自动加（减）一)

4.2 Resetting the LCD module

The LCD module should be initialized bu using /RES terminal.

While turning on the VDD and VSS power supply, maintain /RES terminal at LOW level, After the Power supply stabilized, release the reset terminal(/RES = High)

4.3 Commands Table

The following is a list of host commands supported by UC1698u

C/D: 0: Control, 1: Data

W/R: 0: Write Cycle, 1: Read Cycle

#: Useful Data bits

-: Don't Care

	Command	C/D	W/R	D7	D6	D5	D4	D3	D2	D1	D0	Action	Default	
1	Write Data Byte	1	0	#	#	#	#	#	#	#	#	Write 1 byte	N/A	
2	Read Data Byte	1	1	#	#	#	#	#	#	#	#	Read 1 byte	N/A	
3	Get Status & PM	0	1	GE	MX	MY	WA	DE	WS	MD	MS	Get {Status, Ver, PMO, Product Code, PID, MID}	N/A	
				Ver	PMO[6:0]									
				Product Code (8h)				PID[1:0]		MID[1:0]				
4	Set Column Address LSB	0	0	0	0	0	0	#	#	#	#	Set CA[3:0]	0	
	Set Column Address MSB	0	0	0	0	0	1	0	#	#	#	Set CA[6:4]	0	
5	Set Temp. Compensation	0	0	0	0	1	0	0	1	#	#	Set TC[1:0]	0	
6	Set Power Control	0	0	0	0	1	0	1	0	#	#	Set PC[1:0]	10b	
7	Set Adv. Program Control (double-byte command)	0	0	0	0	1	1	0	0	0	R	Set APC[R][7:0], R = 0 or 1	N/A	
		0	0	#	#	#	#	#	#	#	#			
8	Set Scroll Line LSB	0	0	0	1	0	0	#	#	#	#	Set SL[3:0]	0	
	Set Scroll Line MSB	0	0	0	1	0	1	#	#	#	#	Set SL[7:4]	0	
9	Set Row Address LSB	0	0	0	1	1	0	#	#	#	#	Set RA[3:0]	0	
	Set Row Address MSB	0	0	0	1	1	1	#	#	#	#	Set RA[7:4]	0	
10	Set V _{Bias} Potentiometer (double-byte command)	0	0	1	0	0	0	0	0	0	1	Set PM[7:0]	40H	
		0	0	#	#	#	#	#	#	#	#			
11	Set Partial Display Control	0	0	1	0	0	0	0	1	0	#	Set LC[8]	0	
12	Set RAM Address Control	0	0	1	0	0	0	1	#	#	#	Set AC[2:0]	001b	
13	Set Fixed Lines	0	0	1	0	0	1	0	0	0	0	Set {FLT,FLB}	0	
		0	0	#	#	#	#	#	#	#	#			
14	Set Line Rate	0	0	1	0	1	0	0	0	#	#	Set LC[4:3]	10b	
15	Set All-Pixel-ON	0	0	1	0	1	0	0	1	0	#	Set DC[1]	0	
16	Set Inverse Display	0	0	1	0	1	0	0	1	1	#	Set DC[0]	0	
17	Set Display Enable	0	0	1	0	1	0	1	#	#	#	Set DC[4:2]	110b	
18	Set LCD Mapping Control	0	0	1	1	0	0	0	#	#	#	Set LC[2:0]	0	
19	Set N-Line Inversion	0	0	1	1	0	0	1	0	0	0	Set NIV[4:0]	1DH	
				-	-	-	-	#	#	#	#			
20	Set Color Pattern	0	0	1	1	0	1	0	0	0	#	Set LC[5]	0 (BGR)	
21	Set Color Mode	0	0	1	1	0	1	0	1	#	#	Set LC[7:6]	10b	
22	Set COM Scan Function	0	0	1	1	0	1	1	#	#	#	Set CSF[2:0]	000b	
23	System Reset	0	0	1	1	1	0	0	0	1	0	System Reset	N/A	
24	NOP	0	0	1	1	1	0	0	0	1	1	No operation	N/A	

25	Set Test Control (double-byte command)	0	0	1	1	1	0	0	1	TT		For testing only. Do not use.	N/A	
		0	0	#	#	#	#	#	#	#	#			
26	Set LCD Bias Ratio	0	0	1	1	1	0	1	0	#	#	Set BR[1:0]	11b: 12	
27	Set COM End	0	0	1	1	1	1	0	0	0	1	Set CEN[6:0]	159	
		0	0	-	#	#	#	#	#	#	#			
28	Set Partial Display Start	0	0	1	1	1	1	0	0	1	0	Set DST[6:0]	0	
		0	0	-	#	#	#	#	#	#	#			
29	Set Partial Display End	0	0	1	1	1	1	0	0	1	1	Set DEN[6:0]	159	
		0	0	-	#	#	#	#	#	#	#			
30	Set Window Program Starting Column Address	0	0	1	1	1	1	0	1	0	0	Shared with MTP commands	Set WPC0	0
		0	0	-	#	#	#	#	#	#	#		Set WPP0	0
31	Set Window Program Starting Row Address	0	0	1	1	1	1	0	1	0	1	Shared with MTP commands	Set WPC1	127
		0	0	#	#	#	#	#	#	#	#		Set WPP1	159
32	Set Window Program Ending Column Address	0	0	1	1	1	1	0	1	1	0	Shared with MTP commands	Set WPC1	127
		0	0	-	#	#	#	#	#	#	#		Set WPP1	159
33	Set Window Program Ending Row Address	0	0	1	1	1	1	0	1	1	1	Shared with MTP commands	Set WPC1	159
		0	0	#	#	#	#	#	#	#	#		Set WPP1	159
34	Window Program Mode	0	0	1	1	1	1	1	0	0	#	Set AC[3]	0: Inside	
35	Set MTP Operation control	0	0	1	0	1	1	1	0	0	0	Set MTPC[4:0]	10H	
		0	0	-	-	-	#	#	#	#	#			

LCD Display Memory Mapping (显示屏与显存的映射关系)

Row Address	RAM										MY=0		MY=1		
											SL=0	SL=16	SL=0	SL=16	
00H												COM1	COM17	COM160	COM16
01H												COM2	COM18	COM159	COM15
02H												COM3	COM19	COM158	COM14
03H												COM4	COM20	COM157	COM13
04H												COM5	COM21	COM156	COM12
05H												COM6	COM22	COM155	COM11
06H												COM7	COM23	COM154	COM10
07H												COM8	COM24	COM153	COM9
08H												COM9	COM25	COM152	COM8
09H												COM10	COM26	COM151	COM7
0AH												COM11	COM27	COM150	COM6
0BH												COM12	COM28	COM149	COM5
0CH												COM13	COM29	COM148	COM4
0DH												COM14	COM30	COM147	COM3
0EH												COM15	COM31	COM146	COM2
0FH												COM16	COM32	COM145	COM1
10H												COM17	COM33	COM144	COM160
11H												COM18	COM34	COM143	COM159
12H												COM19	COM35	COM142	COM158
13H												COM20	COM36	COM141	COM157
14H												COM21	COM37	COM140	COM156
15H												COM22	COM38	COM139	COM155
16H												COM23	COM39	COM138	COM154
17H												COM24	COM40	COM137	COM153
18H												COM25	COM41	COM136	COM152
19H												COM26	COM42	COM135	COM151
1AH												COM27	COM43	COM134	COM150
1BH												COM28	COM44	COM133	COM149
1CH												COM29	COM45	COM132	COM148

88H												COM137	COM153	COM24	COM40
89H												COM138	COM154	COM23	COM39
8AH												COM139	COM155	COM22	COM38
8BH												COM140	COM156	COM21	COM37
8CH												COM141	COM157	COM20	COM36
8DH												COM142	COM158	COM19	COM35
8EH												COM143	COM159	COM18	COM34
8FH												COM144	COM160	COM17	COM33
90H												COM145	COM1	COM16	COM32
91H												COM146	COM2	COM15	COM31
92H												COM147	COM3	COM14	COM30
93H												COM148	COM4	COM13	COM29
94H												COM149	COM5	COM12	COM28
95H												COM150	COM6	COM11	COM27
96H												COM151	COM7	COM10	COM26
97H												COM152	COM8	COM9	COM25
98H												COM153	COM9	COM8	COM24
99H												COM154	COM10	COM7	COM23
9AH												COM155	COM11	COM6	COM22
9BH												COM156	COM12	COM5	COM21
9CH												COM157	COM13	COM4	COM20
9DH												COM158	COM14	COM3	COM19
9EH												COM159	COM15	COM2	COM18
9FH												COM160	COM16	COM1	COM17

MX	0												
		SEG1	SEG2	SEG3	SEG4	SEG5				SEG380	SEG381	SEG382	SEG383
	1												
	SEG382	SEG383	SEG384	SEG379	SEG380				SEG5	SEG6	SEG1	SEG2	SEG3

4.4 Basic Operating Sequence

Initialization Sequence

```

void intial(void)
{
  RES=0;
  delay(500);
  RES=1;
  delay(200);
  Comwrite(0xe2);//soft rest
  Comwrite(0x2b);//set power control
  Comwrite(0x81);//set Vbias
  Comwrite(250); //0-255
  Comwrite(0x8d);//set RAM address control

  Comwrite(0xeb);
  //set lcd bias ratio 1/12 22page

  //- - - - MY MX LCO
  Comwrite(0xc0);//set LCD Mapping Control
  Comwrite(0xa3);//set line rate

  Comwrite(0xD1);
  //Set Color Pattern 0xD0(BGR) 0xD1(RGB)

  Comwrite(0xD6);
  //set color mode DC[4]=1;RGB=565

  Comwrite(0xD8);//set com scan function 22page

  Comwrite(0x00);
  Comwrite(0x10);
  Comwrite(0x60);
  Comwrite(0x70);

  Comwrite(0xf1);
  Comwrite(159);//set com end 0-0x7f
  Comwrite(0xF8);//set window program mode or f9
  Comwrite(0xaf);//set Display Enable
  delay(10);
}

void Setadd(uchar xs,ys,uchar xd,yd)
{
  uchar j;
  Comwrite(0xf4);//set start column address
  Comwrite(xs);//0-7f
  Comwrite(0xF6);//set end column address
  Comwrite(xd);//0-7f

  Comwrite(0xF5);//set start row address
  Comwrite(ys);//0-ff
  Comwrite(0xF7);//set end row address
  Comwrite(yd);//0-ff
  j=xs;
  Comwrite(j&0x0f);
  j>>=4;
  Comwrite(0x10+j);
  j=yd&0x0f;
  Comwrite(0x60+j);
  j=yd>>4;
  Comwrite(0x70+j);
}

void Clear(uchar dat)
{
  uchar i;
  uint j;
  Setadd(48,0,128,159);
  for(i=0;i<160;i++)
  for(j=0;j<240;j++)
    Datwrite(dat);
}

```

Specific application, refer to IC data and Programm

5. Inspection Standards

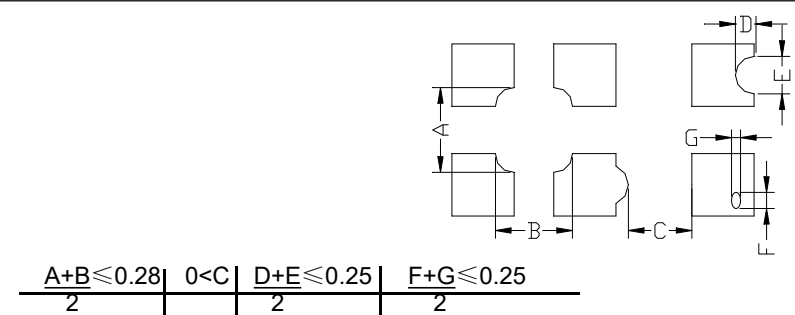
Item	Criterion for defects	Defect type
1) Display on inspection	(1) Non display (2) Vertical line is deficient (3) Horizontal line is deficient (4) Cross line is deficient	Major
2) Black / White spot	Size Φ (mm) $\Phi \leq 0.3$ Acceptable number $0.3 < \Phi \leq 0.45$ Ignore (note) $0.45 < \Phi \leq 0.6$ 3 $0.6 < \Phi$ 1 0	Minor
3) Black / White line	Length (mm) Width (mm) Acceptable number $L \leq 10$ $W \leq 0.03$ Ignore $5.0 \leq L \leq 10$ $0.03 < W \leq 0.04$ 3 $5.0 \leq L \leq 10$ $0.04 < W \leq 0.05$ 2 $1.0 \leq L \leq 10$ $0.05 < W \leq 0.06$ 2 $1.0 \leq L \leq 10$ $0.06 < W \leq 0.08$ 1 $L \leq 10$ $0.08 < W$ follows 2) point defect Defects separate with each other at an interval of more than 20mm	Minor
4) Display pattern	 <p style="text-align: center;"> $\frac{A+B \leq 0.28}{2}$ $0 < C$ $\frac{D+E \leq 0.25}{2}$ $\frac{F+G \leq 0.25}{2}$ </p> <p>Note: 1) Up to 3 damages acceptable 2) Not allowed if there are two or more pinholes every three-fourth inch.</p>	Minor
5) Spot-like contrast irregularity	Size Φ (mm) Acceptable Number $\Phi \leq 0.7$ Ignore (note) $0.7 < \Phi \leq 1.0$ 3 $1.0 < \Phi \leq 1.5$ 1 $1.5 < \Phi$ 0 Note: 1) Conformed to limit samples. 2) Intervals of defects are more than 30mm.	Minor
6) Bubbles in polarizer	Size Φ (mm) Acceptable Number $\Phi \leq 0.4$ Ignore (note) $0.4 < \Phi \leq 0.65$ 2 $0.65 < \Phi \leq 1.2$ 1 $1.2 < \Phi$ 0	Minor
7) Scratches and dent on the polarizer	Scratches and dent on the polarizer shall be in the accordance with "2) Black/white spot", and "3) Black/White line".	Minor
8) Stains on the surface of LCD panel	Stains which cannot be removed even when wiped lightly with a soft cloth or similar cleaning.	Minor
9) Rainbow color	No rainbow color is allowed in the optimum contrast on state within the active area.	Minor
10) Viewing area encroachment	Polarizer edge or line is visible in the opening viewing area due to polarizer shortness or sealing line.	Minor
11) Bezel appearance	Rust and deep damages that are visible in the bezel are rejected.	Minor
12) Defect of land surface contact	Evident crevices that are visible are rejected.	Minor
13) Parts mounting	(1) Failure to mount parts (2) Parts not in the specifications are mounted (3) For example: Polarity is reversed, HSC or TCP falls off.	Minor
14) Part alignment	(1) LSI, IC lead width is more than 50% beyond pad outline. (2) More than 50% of LSI, IC leads is off the pad outline.	Minor
15) Conductive foreign matter (solder ball, solder hips)	(1) $0.45 < \Phi$, $N \geq 1$ (2) $0.3 < \Phi \leq 0.45$, $N \geq 1$, Φ : Average diameter of solder ball (unit: mm) (3) $0.5 < L$, $N \geq 1$, L: Average length of solder chip (unit: mm)	Minor
16) Bezel flaw	Bezel claw missing or not bent	Minor
17) Indication on name plate (sampling indication label)	(1) Failure to stamp or label error, or not legible.(all acceptable if legible) (2) The separation is more than 1/3 for indication discoloration, in which the characters can be checked.	Minor

6. Handling Precautions

6.1 Mounting method

A panel of LCD module made by our company consists of two thin glass plates with polarizers that easily get damaged. And since the module is so constructed as to be fixed by utilizing fitting holes in the printed circuit board (PCB), extreme care should be used when handling the LCD modules.

6.2 Cautions of LCD handling and cleaning

When cleaning the display surface, use soft cloth with solvent (recommended below) and wipe lightly.

- Isopropyl alcohol
- Ethyl alcohol
- Trichlorotrifluoroethane

Do not wipe the display surface with dry or hard materials that will damage the polarizer surface.

Do not use the following solvent:

- Water
- Ketene
- Aromatics

6.3 Caution against static charge

The LCD module uses C-MOS LSI drivers. So we recommend you:

Connect any unused input terminal to V_{dd} or V_{ss} . Do not input any signals before power is turned on, and ground your body, work/assembly areas, assembly equipment to protect against static electricity.

6.4 Packaging

- Module employs LCD elements, and must be treated as such. Avoid intense shock and falls from a height.
- To prevent modules from degradation, do not operate or store them exposed direct to sunshine or high temperature/humidity.

6.5 Caution for operation

-It is an indispensable condition to drive LCD module within the limits of the specified voltage since the higher voltage over the limits may cause the shorter life of LCD module.

- An electrochemical reaction due to DC (direct current) causes LCD undesirable deterioration so that the uses of DC (direct current) drive should be avoided.

-Response time will be extremely delayed at lower temperature than the operating temperature range and on the other hand at higher temperature LCD module may show dark color in them. However those phenomena do not mean malfunction or out of order of LCD module, which will come back in the specified operating temperature.

6.6 Storage

In the case of storing for a long period of time, the following ways are recommended:

- Storage in polyethylene bag with the opening sealed so as not to enter fresh air outside in it. And with not desiccant.
- Placing in a dark place where neither exposure to direct sunlight nor light is. Keeping the storage temperature range.
- Storing with no touch on polarizer surface by any thing else.

6.7 Safety

-It is recommendable to crush damaged or unnecessary LCD into pieces and to wash off liquid crystal by either of solvents such as acetone and ethanol, which should be burned up later.

-When any liquid leaked out of a damaged glass cell comes in contact with your hands, please wash it off well at once with soap and water.