

HANZL

www.hanzl.com.cn

密封件

綜合樣本



服務源自專業...

目 錄

1、各种品牌标准密封件对换表Interchange-----	1
2、常用骨架油封规格表Oil seal Size List-----	2
3、冶金设备常用拉氏油封Rotay Lip Seal for Steed works-----	35
4、轮毂油封Axile Seal -----	39
5、端面密封V-RING/END CAP-----	44
6、高压油封Presewre resistart seal-----	50
7、滚针轴承及直线轴承用油封Oil seal for Neddle Bearing-----	51
8、轴承箱油封Plummer block seal (ZF/TSNG)-----	54
9、组合垫片Bonded Seal-----	57
10、端面密封Gamma Seal-----	61
11、O型圈O-Ring -----	62
12、O型圈盒O-Ring Kits -----	78
13、O型胶条OR Cord -----	80
14、O型圈挡圈Back up Ring -----	81
15、星型圈X-Ring-----	84
16、快速接头密封圈DIN 3869-----	96
17、活塞组合密封DAM/KGD-----	97
18、整体活塞Complete Piston-----	100
19、U型密封圈U-Parking-----	101
20、防尘圈Wiper-----	121
21、骨架防尘圈DUST Seal -----	125
22、斯特封及格莱圈Glyd Ring&Step Ring-----	127
23、抗磨环及支撑环Wearing-----	134
24、金属支撑套DU/BUSHING-----	137

骨架油封

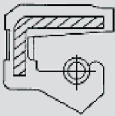
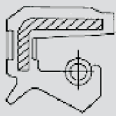
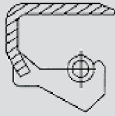
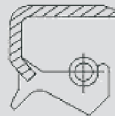
常用各国品牌标准油封规格形式对照

						
GB13871-92	B	FB	W	FW	Z	FZ
NOK	SC	TC	SB	TB	SA	TA
DIN 3760	A	AS	B	BS	C	CS
CFW	BA	BASL	B1	B1 SL	B2	B2 SL
GOETZE	827N	827S	822N	822S	824N	824S
KACO	DG	DGS	DF	DFS	SFK	DFSK
STEFA	CB	CC	BB	BC	DB	DC
CR	HMS4	HMSA1	CRW1	CRWA1	CRWH1	CRWHA1
National	350000	320000	480000	470000		
Garlock	92	94	53,54,62,63,64	3.78		
ATS&FP	G	GP	M	MP	L2M	L2P

骨架油封

- 1、根据工作环境灰尘轻重状况确定油封唇口形式：单唇或双唇
- 2、根据安装孔和密封轴所要求的同轴度确定是内骨架油封或外骨架油封；
- 3、根据工作环境温度的高低来确定骨架油封所采用的材质；
- 4、常用油封材质有四种：

丁 腈 橡 胶： NBR

丙 烯 酸 酯 橡 胶： ACM or PA

硅 橡 胶： SIL or VMQ

氟 橡 胶： VITON or FKM or FPM

- 5、外骨架油封：

俗称铁壳油封。由于其精确的同轴度，被广泛用于精密机械设备或要求较高旋转同轴度的密封系统。对于大型重机设备所选用的骨架油封一般都要求较高的油封刚性，因此应该优先选用SB、TB型油封。当对油封的刚性有更高要求时，推荐选用SA、TA型外骨架油封。

- 6、对于旋转扭矩较低的转轴，如为小型电机选用骨架油封时，应选用不带弹簧的骨架油封如：VC、VB、KC、KB型式。

- 7、骨架油封的内外径公差。

油封轴孔公差表

内径尺寸	内径公差	外径公差 (常规安装)		外径平均公差		最大外径公差	
		外骨架	内骨架	外骨架	内骨架	外骨架	内骨架
up to 25.00		0.10	0.15	(+/-)0.05	(+/-)0.008	0.13	0.25
25.01-50.00		0.10	0.15	(+/-)0.05	(+/-)0.008	0.15	0.30
50.01-75.00		0.10	0.15	(+/-)0.05	(+/-)0.008	0.15	0.36
75.01-100.00		0.13	0.20	(+/-)0.05	(+/-)0.10	0.18	0.46
100.01-150.00		0.13	0.20	(+0.08/-0.05)	(+/-)0.10	0.23	0.58
150.01-200.00		0.15		(+0.08/-0.05)		0.30	
200.01-225.00		0.18		(+0.10/-0.05)		0.38	
225.01-250.00		0.20		(+0.10/-0.05)		0.38	







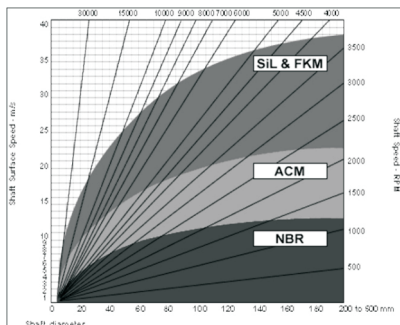

注1、外径平均公差--在油封外径成三等分圆周上测得的数值平均值

注2、最大外径公差--在油封外径上测得的最大数值







- 8、轴径与转速、线速度与油封材质









骨架油封

规格						
4*11*6	SC					
4*11*7	SC					
4*11*8	SC					
4*11*9	SC					
5*12*10	SC					
5*12*11	SC					
5*12*8	SC					
5*12*9	SC					
5*15*5	SC					
5*16*5	SC					
5*17*7		TC				
6*8*4		TC				
6*15*5		TC				
8*14*4	SC					
8*14*5	SC					
8*14*6	SC					
8*14*7	SC					
8*15*5	SC	TC				
8*15*6	SC	TC				
8*15*7	SC	TC				
8*15*8	SC	TC				
8*16*4		TC				
8*16*5		TC				
8*16*6		TC				
10*17*5		TC				
10*18*4		TC				
10*18*5	SC					
10*18*6	SC	TC				
10*19*4		TC				
10*19*7	SC	TC				
10*20*5	SC	TC				
10*20*6	SC	TC				
10*20*7		TC				
10*21*10		TC				
10*21*5	SC					
10*22*7	SC	TC				
10*22*8	SC					
10*23*6		TC				
10*24*7	SC					
10*25*7		TC				
10*26*7	SC					
10*30*12		TC				







服務源自專業...

规格						
10*30*6		TC				
10*30*7	SC	TC				
11*22*7	SC					
12*19*5	SC					
12*20*4	SC	TC				
12*20*5		TC				
12*20*7	SC	TC				
12*21*4	SC	TC				
12*21*7	SC	TC				
12*22*4	SC					
12*22*5	SC	TC				
12*22*6	SC					
12*22*7	SC	TC	SB			
12*22*9		TC				
12*24*10		TC				
12*24*4.5	SC					
12*24*6	SC	TC				
12*24*7	SC	TC				
12*25*10		TC				
12*25*5	SC					
12*25*6		TC				
12*25*7		TC				
12*26*7	SC					
12*28*4.5		TC				
12*28*6		TC				
12*28*7	SC	TC				
12*30*7	SC	TC				
12*32*5	SC					
12*32*7	SC	TC				
13*22*5	SC					
13*25*5	SC					
13*26*7	SC					
13*30*7	SC					
14*22*4		TC				
14*22*5	SC	TC				
14*22*7	SC	TC				
14*24*5	SC					
14*24*6	SC	TC				
14*24*7	SC	TC				
14*25*5	SC					
14*25*7		TC				
14*26*6		TC				







骨架油封

规格						
14*26*7	SC					
14*28*7	SC	TC				
14*30*7	SC					
14*32*7		TC				
14*35*7	SC					
15*22*7	SC					
15*23*5	SC					
15*24*5	SC					
15*24*7	SC	TC		TB		
15*25*5	SC	TC				
15*25*6		TC				
15*25*7		TC		TB		
15*26*5		TC				
15*26*7	SC	TC				
15*27*7		TC				
15*28*5	SC					
15*28*6		TC				
15*28*7	SC	TC				
15*29*6		TC				
15*30*10	SC	TC	SB			
15*30*4.5	SC					
15*30*7	SC	TC		TB		
15*32*7	SC	TC		TB		
15*35*7	SC	TC		TB		
15*35*8	SC					
15*42*10	SC					
15*42*7	SC					
16*24*4	SC			TB		
16*24*5	SC	TC				
16*24*6		TC				
16*24*7	SC		SB			
16*26*7	SC	TC		TB		
16*28*7	SC	TC		TB		
16*30*4.5	SC					
16*30*7	SC	TC	SB			
16*30*8		TC				
16*30*8		TC				
16*32*7	SC		SB			
16*35*7	SC					
17*24*5	SC					
17*25*4	SC	TC				
17*25*6		TC				







服務源自專業...

规格						
17*26*6	SC					
17*27*6		TC				
17*27*7		TC				
17*28*6		TC				
17*28*7	SC	TC	SB	TB		
17*29*5	SC	TC				
17*29*8		TC				
17*30*5	SC					
17*30*6	SC	TC				
17*30*7	SC	TC		TB		
17*30*8		TC				
17*32*7	SC	TC		TB		
17*32*8		TC				
17*34*4	SC					
17*35*7	SC	TC	SB			
17*35*8	SC	TC	SB			
17*37*7	SC					
17*40*10	SC					
17*40*7	SC	TC				
17*47*7		TC				
18*28*7	SC	TC				
18*30*6		TC				
18*30*7	SC	TC		TB		
18*30*8		TC				
18*32*7	SC	TC				
18*32*8	SC					
18*35*7	SC					
18*37*7		TC				
18*40*7	SC					
19*27*4		TC				
19*27*6	SC	TC				
19*30*5		TC				
19*30*7	SC					
19*32*7	SC					
19*35*7	SC					
19*35*8		TC				
19*50*7		TC				
20*26*4			SB			
20*28*5		TC				
20*28*6	SC	TC				
20*28*7	SC					
20*30*5	SC			TB		







骨架油封

规格						
20*30*6	SC	TC				
20*30*7	SC	TC	SB	TB		
20*31*7	SC	TC		TB		
20*32*5	SC		SB			
20*32*6		TC				
20*32*7	SC	TC		TB		
20*33*9	SC					
20*34*5		TC				
20*34*7	SC	TC				
20*35*10	SC	TC				
20*35*5	SC	TC				
20*35*6	SC					
20*35*7	SC	TC	SB			
20*35*8		TC		TB		
20*36*7		TC				
20*36*8		TC				
20*37*7	SC	TC				
20*37*8	SC	TC				
20*38*5	SC					
20*38*7	SC					
20*38*8	SC	TC				
20*40*10	SC	TC		TB		
20*40*7	SC	TC		TB		
20*40*8		TC				
20*42*10	SC					
20*42*7	SC	TC	SB	TB		
20*42*8		TC				
20*42*9		TC				
20*47*10	SC	TC	SB			
20*47*5		TC				
20*47*7	SC	TC	SB			
20*52*10	SC	TC				
20*52*7	SC					
21*28*4	SC					
21*30*6.5	SC					
21*35*7		TC				
21*40*7		TC				
22*31*5	SC	TC				
22*32*5	SC	TC				
22*32*6		TC				
22*32*7	SC	TC		TB		
22*34*7		TC				







服務源自專業...

规格						
22*35*5		TC				
22*35*7	SC	TC		TB		
22*36*7	SC					
22*38*7	SC					
22*38*8		TC				
22*39*6		TC				
22*39*7		TC				
22*40*10	SC					
22*40*7	SC	TC				
22*40*8	SC					
22*42*11		TC				
22*42*7	SC					
22*47*10	SC					
22*47*7	SC					
22*50*7		TC				
23*35*7		TC				
23*40*10	SC					
23*40*6		TC				
23*42*10	SC					
24*33*5		TC				
24*34*7		TC				
24*35*6		TC				
24*35*7	SC	TC	SB			
24*37*7	SC					
24*40*7	SC	TC	SB			
24*42*8	SC					
24*43*6		TC				
24*47*10	SC		SA			
24*47*7	SC	TC				
24*48*10		TC				
25*32*5		TC				
25*32*6	SC	TC				
25*35*10		TC				
25*35*5	SC	TC				
25*35*7	SC	TC	SB	TB		
25*36*8		TC				
25*37*5	SC					
25*37*6	SC	TC				
25*37*7	SC	TC				
25*37*8		TC				
25*38*7	SC	TC		TB		
25*38*8		TC				







骨架油封

规格						
25*40*10	SC	TC	SB			
25*40*5	SC	TC				
25*40*6	SC					
25*40*6		TC				
25*40*7	SC	TC		TB		
25*40*8	SC	TC	SB			
25*40*9		TC				
25*41*6		TC				
25*42*10	SC	TC			SA	
25*42*7	SC	TC				
25*42*8		TC				
25*44*7		TC				
25*45*10	SC	TC		TB		
25*45*6		TC				
25*45*7	SC					
25*46*7	SC					
25*47*10	SC	TC				
25*47*7	SC	TC				
25*47*8			SB	TB		
25*48*8	SC					
25*50*10	SC					
25*52*10	SC	TC		TB		
25*52*7	SC	TC		TB		
25*52*8	SC	TC				
25*62*10	SC	TC				
25*62*8		TC				
26*35*7	SC	TC				
26*37*7	SC					
26*38*5		TC				
26*38*7		TC				
26*40*6	SC					
26*42*7	SC					
26*42*8		TC				
26*47*5		TC				
26*47*7	SC					
26*48*7		TC				
26*52*8		TC				
27*35*4	SC					
27*37*7	SC					
27*40*6		TC				
27*40*7	SC					
27*42*7		TC				







服務源自專業...

规格						
27*47*8	SC					
28*35*8		TC				
28*38*7	SC	TC	SB			
28*40*5	SC					
28*40*7	SC	TC				
28*40*8		TC	SB			
28*42*7		TC	SB			
28*42*8		TC				
28*45*8	SC	TC	SB			
28*47*10	SC	TC				
28*47*7	SC	TC				
28*52*10	SC	TC				
28*52*7	SC	TC				
29*40*7	SC					
30*40*5	SC					
30*40*6		TC				
30*40*7	SC	TC	SB			
30*40*8	SC					
30*42*4.5		TC				
30*42*7			SB			
30*42*7	SC	TC				
30*42*8	SC	TC	SB			
30*44*10	SC					
30*44*9		TC				
30*45*10		TC				
30*45*5	SC					
30*45*6		TC				
30*45*7	SC	TC				
30*45*8	SC	TC	SB	TB		
30*46*8		TC				
30*47*10	SC	TC		TB	SA	
30*47*5	SC					
30*47*6	SC					
30*47*7	SC	TC	SB			
30*47*8	SC	TC		TB		
30*48*8	SC	TC				
30*50*10	SC	TC		TB		
30*50*7	SC	TC				
30*50*8		TC				
30*52*10	SC			TB		
30*52*12		TC				
30*52*7	SC	TC	SB	TB		







骨架油封

规格						
30*52*8		TC				
30*55*10	SC	TC				
30*55*7	SC	TC				
30*60*10	SC	TC		TB		
30*62*7	SC	TC				
30*62*8		TC				
30*68*10	SC					
30*72*10	SC	TC				
31*41*4	SC					
31*52*7	SC					
32*40*7	SC					
32*42*5		TC				
32*42*7	SC	TC				
32*44*7		TC				
32*44*8		TC				
32*45*7	SC					
32*45*7		TC				
32*46*6		TC				
32*47*10	SC	TC				
32*47*7	SC	TC				
32*48*8	SC	TC		TB		
32*50*10	SC	TC				
32*50*8	SC					
32*52*10	SC					
32*52*11		TC		TB		
32*52*7	SC	TC		TB		
32*55*10	SC					
32*62*10		TC				
33*45*7	SC					
33*45*8		TC				
33*46*10.5		TC				
33*50*10	SC					
33*52*10	SC					
34*41*4		TC				
34*46*10	SC					
34*48*7		TC				
34*50*10	SC					
34*50*7		TC				
34*52*10	SC			TB		
34*52*5		TC				
34*52*8	SC					
35*44*4	SC					







服務源自專業...

规格						
35*45*10	SC					
35*45*7	SC	TC	SB			
35*45*8	TC					
35*47*10	SC	TC				
35*47*5	SC					
35*47*7	SC	TC	SB			
35*48*11		TC				
35*48*8		TC				
35*49*6		TC				
35*50*10	SC	TC				
35*50*7	SC	TC				
35*50*8		TC	SB	TB		
35*52*10	SC	TC				
35*52*7	SC	TC				
35*52*8	SC	TC		TB		
35*54*8		TC				
35*55*10	SC	TC				
35*55*11		TC		TB		
35*55*7	SC					
35*55*8	SC	TC		TB		
35*56*10	SC	TC				
35*56*12		TC				
35*56*8		TC				
35*57*9			SB			
35*58*10	SC					
35*58*12		TC				
35*60*10	SC					
35*62*10	SC	TC				
35*62*12		TC	SB			
35*62*7	SC	TC	SB			
35*62*8	SC	TC				
35*72*10	SC	TC				
35*72*12	SC	TC				
35*80*10	SC	TC				
36*47*7	SC					
36*50*10	SC					
36*52*7	SC					
37*62*8	SC					
38*50*7	SC	TC				
38*52*10		TC				
38*52*6				TB		TA
38*52*7	SC	TC	SB	TB		TA







骨架油封

规格						
38*52*8	SC					
38*55*7	SC					
38*55*8		TC	SB			
38*58*10	SC					
38*58*11				TB		
38*59*8		TC				
38*60*10	SC					
38*62*10	SC					
38*62*7	SC	TC				
38*74*11				TB		
39*50*6				TB		
40*50*8	SC					
40*52*10	SC					
40*52*5		TC				
40*52*6	SC					
40*52*7	SC	TC		TB		TA
40*52*8	SC	TC	SB	TB		
40*55*10	SC	TC	SB	TB		
40*55*7	SC	TC				
40*55*8	SC	TC	SB	TB		
40*56*10	SC					
40*56*7		TC				
40*56*8	SC	TC				
40*58*10	SC	TC			SA	
40*58*8		TC		TB		
40*58*9	SC					
40*60*10	SC	TC		TB	SA	
40*60*7	SC	TC				
40*62*10	SC	TC		TB		
40*62*12		TC		TB	SA	
40*62*7	SC	TC	SB			
40*62*8		TC				
40*62*9		TC				
40*65*10	SC	TC				
40*68*10	SC	TC		TB		
40*68*8	SC	TC				
40*70*10	SC					
40*72*10	SC	TC				
40*72*7	SC	TC				
40*80*10	SC	TC				
40*80*8		TC				
40*90*10		TC				







服務源自專業...

规格						
41*48*4		TC				
41*53*7						TA
41*56*10		TC				
42*55*7	SC	TC		TB		
42*55*8	SC	TC				
42*56*7	SC	TC				
42*58*8		TC				
42*60*10	SC					
42*60*7		TC				
42*60*9		TC		TB		
42*62*10	SC	TC	SB			
42*62*12		TC				
42*62*7	SC	TC				
42*62*8	SC	TC	SB			
42*65*11				TB		
42*65*12		TC		TB		
42*68*12		TC				
42*72*10	SC					
42*72*8	SC					
43*50*9				TB		
43*60*10	SC					
44*60*10	SC					
44*62*10		TC		TB		
44*65*10	SC					
44*72*10	SC					
45*55*7	SC		SB			
45*58*7	SC	TC				
45*60*10	SC	TC	SB			
45*60*7	SC	TC				
45*60*8	SC	TC	SB			
45*62*10	SC	TC				TA
45*62*12	SC					
45*62*7	SC	TC				
45*62*8	SC	TC				
45*62*9		TC		TB		
45*65*10	SC	TC	SB		SA	
45*65*8	SC	TC	SB	TB		
45*68*10	SC			TB		
45*68*9		TC				
45*70*10		TC				
45*72*10	SC	TC		TB		
45*72*8	SC	TC				







骨架油封

规格						
45*75*10	SC	TC				
45*75*8	SC	TC				
45*80*10	SC	TC				
45*80*13	SC					
45*85*10	SC	TC				
45*90*10		TC				
46*60*7		TC		TB		
47*58*7		TC				
47*62*9		TC				
47*65*10	SC					
48*60*7		TC				
48*60*9		TC		TB		
48*62*7		TC		TB		
48*62*8	SC	TC				
48*62*9	SC	TC	SB	TB		
48*62*10	SC	TC				
48*65*7		TC				
48*65*8		TC				
48*65*9	SC	TC		TB		
48*65*10	SC	TC	SB			
48*65*12		TC				
48*68*10	SC	TC				
48*70*8		TC				
48*70*9		TC				
48*70*10	SC	TC				
48*70*12		TC				
48*72*7		TC				
48*72*8	SC	TC				
48*72*10	SC	TC			SA	
48*72*12	SC	TC				
48*74*10		TC				
48*80*8	SC	TC				
48*80*10	SC	TC				
48*80*13	SC					
49*62*8	SC					
49*86*12		TC				
50*60*7		TC	SB			
50*60*8		TC				
50*60*10		TC				
50*62*7	SC	TC	SB			
50*62*8		TC				
50*62*10		TC				







服務源自專業...

规格						
50*64*7		TC				
50*64*8		TC				
50*64*10		TC		TB		
50*65*8	SC	TC	SB			
50*65*9		TC		TB		
50*65*10	SC	TC		TB		
50*67*9		TC				
50*67*11		TC				
50*68*8	SC	TC				
50*68*9		TC		TB		
50*68*10	SC	TC				
50*68*12	SC					
50*70*8	SC	TC				
50*70*9		TC	SB	TB		
50*70*10	SC	TC				
50*70*12	SC	TC			SA	
50*72*6	SC					
50*72*7		TC		TB		
50*72*8	SC	TC				
50*72*10	SC	TC	SB			
50*72*12	SC	TC	SB	TB		
50*72*8	SC	TC	SB			
50*73*9		TC				
50*74*12		TC				
50*75*8		TC				
50*75*10	SC	TC				
50*75*12		TC				
50*76*10	SC	TC				
50*76*12		TC				
50*78*10		TC				
50*80*7		TC				
50*80*8	SC	TC				
50*80*10	SC	TC		TB		
50*80*12		TC			SA	
50*80*13	SC	TC				
50*82*12		TC				
50*85*10	SC	TC				
50*85*12		TC				
50*90*10	SC	TC				
50*90*12		TC				
50*100*10		TC				
52*62*8		TC				







骨架油封

规格						
52*63*8		TC				
52*65*8	SC					
52*65*9			SB	TB		
52*68*8	SC	TC				
52*68*10		TC				
52*68*13		TC				
52*70*7	SC					
52*70*8		TC				
52*70*9		TC		TB		
52*70*10		TC				
52*72*8	SC	TC				
52*72*9	SC	TC				
52*72*10	SC	TC				
52*72*12		TC		TB		
52*75*8		TC				
52*75*10		TC				
52*75*12	SC	TC		TB		
52*80*10	SC	TC				
52*80*13	SC					
52*85*8	SC					
52*85*10	SC	TC				
53*68*10	SC					
53*72*10		TC				
53*90*13		TC				
54*72*10	SC	TC				
54*76*8		TC				
54*76*10		TC				
54*81*10		TC				
54*82*10		TC				
54*92*12		TC				
55*65*10		TC				
55*68*8	SC	TC	SB	TB		
55*70*6		TC				
55*70*7		TC				
55*70*8	SC	TC				
55*70*9		TC				
55*70*10	SC	TC				
55*70*12		TC				
55*72*7		TC				
55*72*8	SC	TC	SB			
55*72*9		TC		TB		
55*72*10	SC	TC				





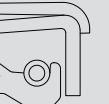

服務源自專業...

规格						
55*72*12	SC	TC		TB		
55*75*8	SC	TC	SB			
55*75*10	SC	TC				
55*75*12	SC	TC		TB		
55*76*10		TC				
55*76*12		TC				
55*78*8	SC	TC				
55*78*10	SC	TC				
55*78*12		TC	SB	TB		
55*80*8	SC	TC		TB		
55*80*10	SC	TC		TB		TA
55*80*12		TC		TB		
55*80*13	SC	TC				
55*82*10		TC				
55*82*12		TC				
55*85*8	SC	TC				
55*85*10	SC	TC				
55*90*10	SC	TC				
55*90*8	SC	TC				
55*100*10		TC				
56*69*10	SC					
56*70*8		TC				
56*70*9		TC				
56*72*8		TC				
56*72*10		TC				
56*80*8	SC	TC				
57*71*7		TC				
57*72*10	SC			TB	SA	
57*80*8		TC				
58*68*9		TC				
58*72*8	SC	TC				
58*72*10	SC					
58*74*8		TC				
58*75*8		TC		TB		
58*75*9		TC		TB		
58*75*10	SC	TC				
58*80*8	SC					
58*80*10		TC				
58*80*12	SC	TC		TB		
58*80*13	SC					
58*82*10	SC					
58*84*10		TC				







骨架油封

规格						
58*85*8		TC				
58*85*10		TC				
58*90*10	SC	TC				
58*90*11	SC	TC				
59*72*12				TB		
60*70*12		TC				
60*72*8	SC	TC		TB		
60*72*10		TC				
60*72*12		TC				
60*75*8	SC	TC				
60*75*9		TC				
60*75*10	SC					
60*75*12	SC					
60*78*6	SC					
60*75*8	SC	TC		TB		
60*78*9		TC	SB			
60*80*8	SC	TC				
60*80*10	SC	TC		TB	SA	
60*80*12	SC	TC	SB			
60*80*13	SC	TC			SA	
60*82*9		TC				
60*82*10		TC				
60*82*12	SC	TC		TB		
60*85*8	SC	TC		TB		
60*85*10	SC	TC		TB	SA	
60*85*12	SC	TC				
60*85*13	SC	TC				
60*86*12		TC				
60*90*8	SC	TC				
60*90*10	SC	TC		TB		
60*90*12		TC	SB			
60*90*13	SC					TA
60*92*12		TC				
60*95*10	SC	TC				
60*95*12		TC				
60*95*13		TC				
60*100*10	SC	TC				
60*100*12		TC				
60*100*13		TC				
60*100*14		TC				
60*110*10	SC					
60*110*12		TC				





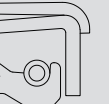

服務源自專業...

规格						
60*110*13	SC	TC				
62*80*8		TC				
62*80*9		TC		TB		
62*80*10	SC	TC				
62*80*12		TC				
62*85*9				TB		
62*85*10	SC	TC		TB		
62*85*12		TC		TB		
62*90*10	SC	TC				TA
62*90*12		TC				
62*95*10	SC					
62*95*13		TC				
63*80*9		TC				
63*85*10	SC					
63*90*10		TC				
63*90*12		TC		TB		
64*80*8		TC	SB			
64*80*13		TC				
64*90*13		TC				
65*75*8		TC				
65*80*8	SC	TC		TB		
65*80*9	SC					
65*80*10	SC	TC				
65*80*12	SC	TC				
65*82*10		TC	SB			
65*82*12		TC				
65*85*8	SC	TC				
65*85*10	SC	TC		TB		
65*85*12	SC	TC	SB			
65*85*13	SC	TC				
65*88*12		TC	SB	TB		
65*90*10	SC	TC	SB	TB		
65*90*12	SC	TC		TB		TA
65*90*13	SC	TC		TB		
65*92*12	SC	TC				
65*95*10	SC	TC				
65*95*12	SC					
65*95*13	SC	TC				
65*95*14	SC	TC				
65*100*10	SC	TC				
65*100*12	SC	TC				
65*100*13		TC		TB		







骨架油封

规格						
65*110*10		TC				
65*110*12		TC				
65*120*10		TC				
65*120*12		TC				
65*120*13		TC				
67*95*13		TC				
68*80*8	SC					
68*82*7	SC					
68*85*10		TC		TB		
68*90*8		TC				
68*90*10	SC	TC		TB		
68*90*12	SC	TC		TB		
68*90*13		TC				
68*92*12		TC				
68*95*10		TC				
68*100*10		TC				
68*100*13	SC	TC				
68*110*12		TC				
68*110*13		TC				
68*115*13	SC	TC				
70*85*7	SC					
70*85*8	SC	TC	SB			
70*85*10	SC	TC				
70*88*8		TC				
70*88*10		TC				
70*88*12		TC		TB		
70*90*7		TC				
70*90*8	SC					
70*90*10	SC	TC	SB	TB	SA	TA
70*90*12	SC	TC			SA	TA
70*90*13	SC	TC		TB	SA	
70*92*10		TC				
70*92*12		TC	SB			TA
70*92*13		TC				
70*95*10	SC	TC				
70*95*12		TC		TB		
70*95*13		TC		TB		
70*100*10	SC	TC				
70*105*13	SC	TC			SA	
70*110*8	SC	TC				
70*110*10	SC	TC				
70*110*12	SC	TC				







服務源自專業...

规格						
70*110*13	SC	TC				TA
70*120*12	SC	TC				
70*120*13	SC					
70*125*12		TC				
72*86*7		TC				
72*88*8		TC				
72*90*10		TC				
72*92*10		TC				
72*92*12		TC				
72*94*8		TC		TB		
72*94*10		TC				
72*94*12		TC				
72*95*10	SC	TC		TB		
72*100*10	SC	TC				
72*100*12		TC				
72*105*13		TC		TB		
72*110*12		TC				
72*110*13		TC				
74*90*10		TC				
74*95*10		TC				
75*90*8	SC	TC				
75*90*10	SC	TC				
75*90*12	SC	TC				
75*92*12		TC				
75*95*7	SC					
75*95*8		TC				
75*95*10	SC	TC	SB			
75*95*12	SC	TC		TB		
75*95*13	SC	TC				TA
75*95*14		TC				
75*96*11				TB		
75*100*10	SC	TC	SB	TB		
75*100*12		TC	SB		SA	
75*100*13	SC	TC		TB		
75*105*10		TC				
75*105*12	SC	TC		TB		TA
75*105*13		TC				
75*110*12	SC	TC				
75*110*13		TC		TB		
75*115*10	SC	TC				
75*115*12		TC				
75*115*13		TC				







骨架油封

规格						
75*120*12	SC					
75*120*13		TC				
75*125*13		TC				
75*130*13	SC	TC				
76*94*12		TC				
77*100*10	SC					
78*100*10	SC	TC				
78*100*12		TC				
78*100*13	SC	TC				TA
80*95*8	SC					
80*95*10		TC				
80*96*6		TC				
80*98*10		TC				
80*100*7		TC				
80*100*8		TC				
80*100*10	SC	TC	SB	TB		
80*100*12	SC	TC			SA	
80*100*13	SC	TC	SB	TB		
80*105*10		TC				
80*105*12	SC					
80*105*13	SC	TC	SB	TB	SA	TA
80*105*14		TC				
80*107*12		TC				
80*110*10	SC	TC				TA
80*110*12	SC	TC				
80*110*13	SC			TB	SA	TA
80*115*10		TC				
80*115*12	SC	TC				
80*115*13		TC				
80*120*10		TC				
80*120*12		TC				
80*120*13	SC	TC				
80*125*10		TC				
80*125*12	SC	TC				
80*125*13		TC				
80*140*13	SC	TC				
82*100*8	SC					
82*105*12		TC				
82*105*13		TC				
83*110*13	SC	TC				
85*100*9	SC			TB		
85*100*10		TC				







服務源自專業...

规格						
85*100*12		TC			SA	TA
85*100*13		TC				
85*105*8	SC					
85*105*10		TC		TB		
85*105*12	SC	TC				
85*105*13	SC	TC		TB		
85*110*10	SC	TC				
85*110*12	SC	TC				TA
85*110*13		TC	SB	TB		SA
85*110*14		TC				
85*115*12		TC				
85*115*13		TC				
85*115*15	SC	TC				
85*120*10		TC				
85*120*12	SC	TC				
85*120*12	SC			TB		
85*120*13	SC	TC				
85*120*15	SC					
85*125*13		TC				
85*125*14		TC				
85*125*15		TC				
85*130*10		TC				
85*130*12	SC	TC				
85*140*12	SC	TC				
85*140*13		TC				
88*110*13		TC				
90*105*6	SC					
90*105*10	SC					
90*105*12		TC				
90*110*8	SC	TC				
90*110*10	SC	TC		TB		
90*110*12	SC	TC				
90*110*13	SC	TC		TB		
90*110*8	SC	TC				
90*114*12		TC				
90*115*9		TC				
90*115*10	SC					
90*115*12	SC					
90*115*13	SC	TC	SB	TB		
90*120*12	SC	TC				
90*120*13	SC	TC	SB		SA	
90*120*15		TC				







骨架油封

规格						
90*125*13	SC	TC				
90*125*15		TC				
90*125*17		TC				
90*130*12	SC	TC				
90*130*13		TC				
90*135*12		TC				
90*135*13		TC				
90*140*10		TC				
90*140*13		TC				
92*110*12		TC				
92*120*12		TC				
92*120*13		TC				TA
95*110*10	SC					
95*110*12	SC					
95*110*13		TC				
95*115*12		TC				
95*115*13	SC	TC		TB	SA	
95*120*10		TC				
95*120*12	SC	TC	SB			
95*120*13	SC	TC		TB		TA
95*125*12	SC	TC				
95*125*13	SC	TC				
95*127*12		TC				
95*130*12		TC				
95*130*13		TC				
95*130*15		TC		TB		
95*135*13	SC	TC				
98*120*12		TC				
98*120*13	SC					
100*115*9	SC					
100*115*10	SC	TC				
100*115*12		TC				
100*118*12		TC				
100*120*10	SC					
100*120*11	SC					
100*120*12	SC	TC		TB		
100*120*13	SC	TC				TA
100*120*15		TC				
100*125*12	SC	TC	SB			
100*125*13	SC	TC		TB		TA
100*125*14		TC		TB		
100*130*10		TC				







服務源自專業...

规格						
100*130*12	SC	TC	SB	TB	SA	
100*130*13	SC	TC		TB		
100*130*15		TC		TB		
100*135*12		TC				
100*135*13		TC				
100*135*15		TC				
100*140*13	SC	TC				
100*150*12	SC					
100*150*13	SC	TC				
100*170*15		TC				
100*180*13	SC					
102*116*14				TB		
105*120*11		TC				
105*120*12	SC					
105*125*12		TC				
105*125*13	SC			TB		
105*130*10		TC				
105*130*12	SC	TC		TB		
105*130*13	SC	TC		TB	SA	
105*130*15		TC				
105*135*13	SC					
105*140*12	SC	TC	SB		SA	
105*140*13	SC			TB		
105*140*15		TC				
105*145*14		TC				
105*150*15	SC					
106*126*12		TC				
110*130*8	SC					
110*130*12	SC	TC			SA	
110*130*13	SC	TC		TB		
110*135*12		TC				
110*135*13		TC				
110*140*10	SC	TC	SB			
110*140*11		TC				
110*140*12	SC	TC	SB			TA
110*140*13	SC	TC			SA	TA
110*140*14		TC	SB	TB		
110*150*13	SC	TC				
110*160*12		TC				
110*160*13		TC				
110*170*14		TC				
110*170*15		TC				







骨架油封

规格						
112*136*12		TC				
112*140*13	SC					
112*140*15		TC				
114*140*13					SA	
114*145*14		TC				
115*130*6		TC				
115*130*12	SC					
115*135*10	SC			TB		
115*140*12	SC	TC				
115*140*13	SC	TC		TB		TA
115*140*14		TC				
115*140*15	SC	TC	SB		SA	
115*145*13		TC				
115*145*14		TC		TB		
115*150*12	SC					
115*150*13		TC				
115*160*15	SC	TC				
120*140*10.5				TB		
120*140*12		TC		TB		
120*140*13	SC	TC	SB		SA	
120*140*14		TC				
120*140*15		TC				
120*150*10	SC					
120*150*12	SC	TC				
120*150*13	SC	TC			SA	
120*150*14		TC		TB		
120*150*15	SC	TC			SA	TA
120*155*16		TC				
120*160*12	SC	TC	SB			
120*160*14		TC				
120*160*15	SC	TC				
120*160*16		TC				
125*140*10	SC					
125*143*13		TC				
125*145*13		TC				
125*150*12	SC	TC		TB		
125*150*13	SC	TC		TB		
125*150*14		TC				
125*150*15		TC			SA	
125*155*12		TC				
125*155*13		TC				
125*155*14	SC	TC	SB	TB		







服務源自專業...

规格						
125*160*12	SC	TC				
125*160*13	SC					
125*160*14		TC				TA
125*160*15	SC	TC			SA	
125*165*13		TC				
126*164*16	SC	TC				
130*150*10	SC	TC		TB		
130*150*12	SC	TC				
130*150*14		TC		TB		
130*160*12	SC	TC	SB			
130*160*13	SC	TC				
130*160*14		TC	SB	TB		
130*160*15	SC	TC	SB		SA	
130*162*14		TC				
130*165*13	SC				SA	
130*170*12	SC					
130*170*15		TC				TA
132*160*12		TC				
132*160*13		TC				
132*160*15		TC				
135*150*15		TC				
135*160*12	SC			TB		
135*160*13	SC	TC			SA	
135*160*14		TC				
135*165*12	SC					
135*165*13		TC				TA
135*165*14	SC	TC		TB		
135*170*12	SC	TC				
135*170*13		TC			SA	
135*170*15	SC	TC	SB		SA	
135*200*12		TC				
135*200*15		TC				
140*160*12		TC				
140*160*13	SC	TC				
140*165*12	SC					
140*170*12	SC					
140*170*13	SC					
140*170*14	SC	TC		TB		
140*170*15	SC	TC			SA	TA
140*170*16		TC				
140*180*15	SC	TC	SB		SA	
145*170*13	SC	TC		TB		







骨架油封

规格						
145*175*14	SC	TC		TB		
145*175*15	SC	TC			SA	
145*180*12	SC					
146*170*18		TC				
148*170*15		TC			SA	
150*170*12	SC	TC				
150*170*15		TC				
150*175*14				TB		
150*180*12	SC	TC		TB		
150*180*13	SC	TC				
150*180*14	SC	TC	SB	TB		
150*180*15	SC	TC		TB	SA	TA
150*180*16		TC				
150*180*18		TC				
150*225*15		TC				
154*175*13				TB		
155*172*14				TB		
155*174*12	SC					
155*175*14			SB			
155*180*14		TC		TB		
155*180*15		TC		TB		
155*180*17				TB		
155*185*13		TC				
155*185*14		TC		TB		
155*190*15	SC					TA
155*190*17		TC				
160*180*10		TC				
160*180*12		TC				
160*180*13		TC				
160*180*15	SC	TC			SA	
160*185*10	SC				SA	
160*185*12		TC				
160*185*13	SC	TC		TB		
160*190*12		TC				
160*190*13	SC		SB			TA
160*190*15	SC	TC		TB		TA
160*190*16			SB		SA	
160*200*12	SC					
160*200*14		TC				
160*200*15		TC				
160*210*22.5		TC				
165*190*13	SC	TC			SA	







服務源自專業...

规格						
165*200*15	SC				SA	TA
170*190*13	SC					
170*190*15		TC				
170*200*12	SC					
170*200*13		TC				
170*200*14	SC					
170*200*15	SC	TC		TB	SA	
170*210*13	SC					
175*200*15	SC				SA	TA
180*200*13	SC					
180*200*15	SC	TC				
180*210*15	SC	TC		TB		
180*215*16	SC	TC	SB			
180*235*13	SC					
180*210*15	SC	TC			SA	
185*210*13	SC	TC	SB			TA
185*210*14		TC				
185*210*15		TC				
190*220*12	SC	TC				
190*220*14		TC		TB		
190*220*15	SC	TC	SB	TB	SA	
190*230*16		TC		TB		
195*230*17	SC					
195*240*15		TC				
200*225*15	SC					
200*230*15	SC	TC	SB		SA	
200*235*16	SC			TB		
200*250*15	SC	TC				
205*235*16		TC				
205*250*15	SC					
210*240*15	SC	TC		TB		
220*250*15	SC	TC	SB		SA	TA
220*260*15		TC				
220*260*16		TC				
220*270*15		TC				
230*255*10	SC		SB			
230*260*15	SC	TC	SB			
230*285*23	SC		SB		SA	
235*265*15	SC					
240*270*15	SC	TC	SB		SA	
240*275*16	SC					
240*280*15	SC					







骨架油封

规格						
250*280*15	SC	TC	SB		SA	TA
250*310*25	SC			TB		
260*290*15	SC					
260*290*16	SC				SA	TA
260*300*15		TC				
260*300*20	SC		SB		SA	TA
265*290*16	SC					
270*300*15		TC				
270*310*20		TC				
280*310*15	SC					
280*310*16		TC			SA	
280*320*18		TC		TB		
280*320*20	SC	TC		TB	SA	TA
280*320*22		TC				
300*335*18	SC			TB		TA
300*340*18	SC		SB			
300*340*20	SC					
300*360*20		TC				
305*355*23			SB			
310*350*18	SC					
310*350*20	SC					
310*370*25			SB			
310*370*28			SB	TB		
320*358*20			SB			
320*360*18	SC	TC			SA	
320*360*20	SC	TC	SB	TB	SA	
320*360*25			SB			
320*380*25			SB			
320*380*28			SB	TB		
325*365*25			SB			
325*375*25			SB	TB		
330*370*18				TB	SA	TA
330*370*20	SC	TC	SB			
330*370*25			SB	TB		
330*390*25			SB			
330*390*28			SB	TB		
340*380*18	SC	TC			SA	
340*380*20	SC	TC	SB		SA	
340*400*25			SB			
340*400*28			SB	TB		
350*380*15	SC					
350*390*18	SC			TB	SA	







服務源自專業...

规格						
350*390*20			SB			
350*400*25			SB			
350*410*25			SB			
350*410*28			SB	TB		
360*390*18	SC					
360*400*17			SB	TB		
360*400*18	SC				SA	TA
360*400*20	SC	TC	SB	TB	SA	
360*400*25			SB	TB		
360*420*25			SB	TB	SA	
360*420*28			SB	TB		
365*405*18			SB		SA	
370*415*20			SB	TB		
370*430*25			SB			
370*430*28			SB	TB		
375*420*28			SB			
380*420*20	SC		SB		SA	
380*430*19			SB		SA	
380*440*25			SB			TA
380*440*28			SB	TB		
390*430*18			SB		SA	
390*440*25			SB	TB		
390*450*25			SB			
390*450*28			SB	TB		
395*430*18			SB		SA	
400*440*20	SC		SB	TB	SA	
400*450*15.6			SB			
400*460*25			SB			
400*460*28			SB	TB		
410*450*20			SB		SA	
410*470*25			SB			
410*470*28			SB	TB		
415*475*23			SB			
420*460*16	SC					
420*460*20	SC	TC	SB		SA	
420*470*20			SB			
420*480*25			SB		SA	
420*480*28			SB	TB		
425*475*22			SB	TB		
430*465*18			SB			
430*470*20			SB	TB		
430*480*25			SB	TB		

骨架油封

规格						
430*480*30	SC					
440*470*20					SA	
440*480*20	SC	TC	SB		SA	TA
440*490*25			SB	TB		
440*500*25			SB	TB		
445*480*16		TC			SA	
450*480*17.5			SB			
450*500*20	SC					
450*500*25	SC		SB	TB		
450*510*25	SC		SB			
450*510*28			SB	TB		
460*500*20	SC		SB		SA	
460*520*25	SC		SB			
465*510*20			SB	TB		
470*510*20					SA	
470*520*22		TC	SB			
470*520*25		TC				
470*530*25			SB	TB		
475*530*18					SA	
480*520*20	SC	TC	SB		SA	TA
480*530*22			SB			
480*530*25	SC			TB		
480*540*25	SC		SB			
480*540*28			SB	TB		
490*550*25			SB			
490*550*28			SB	TB		
500*540*20	SC		SB		SA	
500*550*20				TB	SA	
500*560*25			SB			
500*560*28			SB	TB		
510*560*25			SB			
520*560*20			SB			
520*580*20					SA	
520*580*25			SB			
530*580*22			SB	TB		TA
540*590*25			SB	TB		
540*600*25			SB	TB		
550*610*25			SB			
550*610*28			SB	TB		
560*610*20	SC		SB		SA	
560*620*25			SB		SA	
560*620*30			SB	TB		

服務源自專業...

规格						
570*620*22			SB			
570*630*25			SB			
580*640*25			SB	TB		
580*640*30			SB	TB		
600*640*20					SA	
600*650*25			SB	TB		
600*660*25			SB			
610*670*23			SB			
620*670*25			SB			
620*680*23			SB			
630*670*20			SB			
635*685*25			SB			
640*680*20					SA	
640*690*25			SB	TB		
650*710*25			SB			
650*720*25			SB			
660*740*45			SB	TB		
670*720*25			SB			
685*745*25			SB			
690*730*20			SB			
700*750*20			SB			
710*760*20					SA	
710*760*25			SB			
710*770*25			SB			
710*770*30			SB	TB		
720*768*22			SB			
730*790*25			SB			
735*795*25			SB			
740*790*25			SB			
750*800*25			SB			
760*813*22			SB			
780*830*25			SB			
800*870*25			SB	TB		
810*870*25			SB			
820*900*35			SB	TB		
840*910*25			SB			
850*900*25			SB			
870*920*25			SB			
890*950*25			SB			
900*950*25			SB			
940*1000*25			SB			
950*1000*23			SB			

拉氏油封

拉氏油封

拉氏油封 (Radimatic)是德国MERLEL设计开发的一种旋转唇型油封，是一种不同于传统的金属骨架油封，而是采用加强型纤维组织为骨架来增加油封的刚性。

主要形式：

R35标准型，单个使用。

R36带注油孔，背靠背安装。

R37带注油孔、注油槽，背靠背使用。

R58带注油孔、注油槽，成对并列使用于脂润滑轴承，唇口向外。

主要用于：

- 1、轧钢机械
- 2、船舶设备
- 3、隧道机械
- 4、采矿机械
- 5、造纸机械
- 6、水泥机械
- 7、电厂

相关产品

- 1、美国JM.Cilpper LUP系列
- 2、英国James Walker D6系列
- 3、意大利CARCO SEAL UN系列



R35

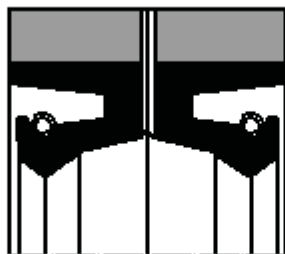

R36

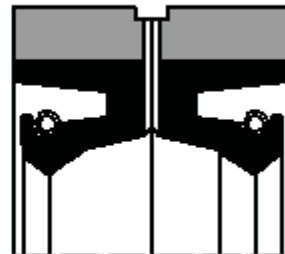

R37

服務源自專業...

内径(d)	外径(D)	高度(h)
100	125	10
100	125	12.5
100	132	12.5
100	140	16
101.6	133.35	12
110	135	10
110	135	12.5
110	140	13
110	140	16
110	150	16
120	150	16
120	160	16
125	155	12
125	165	15.8
127	158.75	12.5
130	160	15
130	170	16
132.5	172.5	16
133	165	12.5
140	170	16
140	180	16
146	177.8	16
150	180	12.7
150	190	16
156	196	16
160	190	16
160	200	16
160	200	18
170	200	13
170	200	16
170	210	16
177.8	215.9	16
180	210	14
180	215	18
180	220	16
181	219.1	16
185	225	16
190	220	16
190	225	18
190	230	16
195	235	16
200	230	14
200	235	18

内径(d)	外径(D)	高度(h)
210	245	18
210	250	18
220	260	16
225	265	16
230	260	15.7
230	270	16
230	280	20
230	280	22.5
235	265	15
235	266.7	16
235	275	16
240	275	18
240	280	16
245	285	16
247.65	292.1	18.6
250	290	16
250	294	20
260	290	16
260	300	14
260	300	18
260	304	20
260	305	16
270	310	20
270	314	20
272	314	20
275	315	18
275	319.5	19
275.8	307.6	13.5
280	320	16
280	320	18
280	320	20
280	324	20
285	329	20
290	330	20
290	334	20
292.1	330.2	19.5
292.1	342.9	22.6
295	339	20
300	340	16
300	340	20
300	344	20
304	348	20
305	355	22.5

拉氏油封

内径(d)	外径(D)	高度(h)
310	354	20
311	345	18
315	355	16
317.5	355.6	16
320	350	15
320	255	16
320	260	18
320	260	20
320	364	20
325	369	20
330	374	20
330.2	368.3	22.5
335	375	15
340	372	20
340	384	20
345	389	20
350	380	20
350	390	20
350	394	20
355	399	20
360	400	20
360	404	20
370	414	20
370	420	20
374.65	419.1	22
380	420	20
380	424	20
385	429	20
385	435	22
387	431	22
390	430	20
390	434	20
393.7	444.5	22.6
395	432	18.5
395	439	20
400	440	20
400	440	21.9
400	444	20
400	450	22
400	438.15	19
406.4	444.5	17
406.4	457.2	20.6
406.4	457.2	23













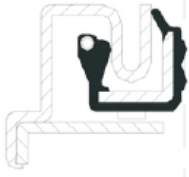

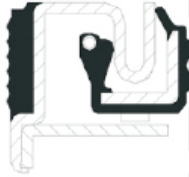

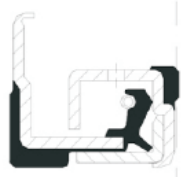
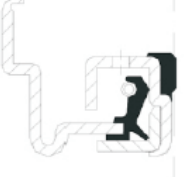



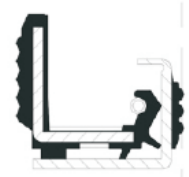

内径(d)	外径(D)	高度(h)
410	454	20
410	460	22
415	465	22
416	466	22
420	460	20
420	464	20
420	470	22
430	480	22
431.8	469.9	22
435	485	22
440	480	26
440	490	22
440	490	28
445	485	18
445	495	22
450	500	22
454	500	18
460	510	22
466.7	510	25
469.9	520.7	23
470	520	22
480	524	20
480	530	22
480	530	25
485	535	22
493	543	26
500	544	20
500	545	20
500	550	22
510	554	20
515	565	22
520	570	22
525	575	22
530	580	22
535	585	22
540	585	18
540	590	22
540	590	25
550	600	23.5
560	604	20
560	610	22
565	615	22
570	620	22

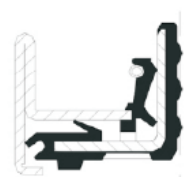
服務源自專業...

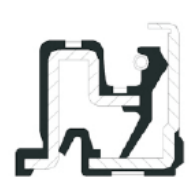
内径(d)	外径(D)	高度(h)
571.5	622.3	22
580	630	22
590	640	22
592	642	22
600	640	20
600	650	22
600	650	28
600	660	30
610	660	22
610	674	25
620	684	25
625	655	20
625	689	25
636	692	30.5
640	704	25
650	700	22
650	714	25
660	700	18
660	704	20
660.4	711.2	25.4
670	714	22
670	734	25
676	740	25
680	730	20
690	740	22
690	754	25
698.5	749.3	22.5
700	750	25
700	764	25
706	770	26
710	760	20
710	760	25
710	770	30
710	774	25
720	780	25
730	770	20
730	794	25
735	799	25
750	810	25
750	814	25
760	800	20
760	804	20
761.8	803.2	25.4

内径(d)	外径(D)	高度(h)
770	834	25
775	839	25
780	820	17.7
780	844	25
800	860	30
800	864	25
805	869	25
810	874	25
820	870	25
820	884	28
830	894	25
830	894	28
835	899	25
840	904	25
840	904	28
850	910	25
860	920	22
860	920	25
860	924	25
870	930	20.5
870	930	27
870	934	25
880	940	30
880	944	25
890	954	25
900	960	27
910	974	25
930	994	25
970	1020	30
970	1030	21.5
970	1034	25
985	1045	24.5
1000	1060	30
1000	1064	25
1020	1084	25
1060	1124	25
1100	1160	25
1100	1174	25
1130	1194	25
1220	1284	25
1250	1314	25
1320	1420	49
1480	1544	25

轮毂油封

				
CH1	CH2	CH3	CH4	CH5
				
CH6	CH7	CH8	CH9	CH10
				
CH11	CH12	CH13	CH14	CH15
				
CH16	CH17	CH18	CH19	CH20
				
CH21	CH22	CH23	CH24	CH25

服務源自專業...

订货号	规格	尺寸
12132-N10	AXLE	30*45*8
12088-N10	AXLE	30*50*8/14
12133-N10	AXLE	32*52*8
CH0296-N10	AXLE	35*65*14.5/17
12137-N10	AXLE	40*62*8
CH0085-V1A	AXLE	46*73/79*14.5/17
CH0074-N10	AXLE	48*72*10
CH0381-N10-SS	AXLE	53*79*13
CH0284-N10	AXLE	53.2*78*13/14
CH0356-N3A	AXLE	55*80*12.5/14
CH0356-V3A	AXLE	55*80*12.5/14
CH0142-N10	AXLE	60*90*13.5
CH0142-N10-XX	AXLE	60*90*13.5
CH0229-N10-XX	AXLE	60*94*16
CH0168-N10	AXLE	65*85*10
CH0304-V30	AXLE	65*90*13/14.5
CH0285-N10	AXLE	65*92*10/15
CH0181-V3A	AXLE	70*100*13.5/15
CH0062-V35	AXLE	70*90*13.5/14.5
CH0112-N10	AXLE	70*95*10.5
CH0098-N10	AXLE	73.2*106*13.5
CH0028-N10	AXLE	75*100*14
CH0113-V10-KIT	AXLE	76*125.5/136*19.4/20.5
CH0113-V12	AXLE	76*125.5/136*19.4/20.5
CH0182-N10	AXLE	76.2*95.25/104.77*16.8
CH0106-V12	AXLE	82.5*108/118.5*19/22
CH0195-V30-XX	AXLE	85*110/115*7.5/8.5
CH0306-V30	AXLE	85*120*10/21
CH0129-V30	AXLE	85*150*16.35/20
CH0294-V30	AXLE	85*150*16.35/24
CH0110-V3A	AXLE	87.26*120.76*15.4
CH0131-N12	AXLE	90*130*14/17
CH0131-N12-XX	AXLE	90*130*14/17
CH0131-P32	AXLE	90*130*14/17
CH0131-V12-XX	AXLE	90*130*14/17
CH0198-N12	AXLE	90*130*14/20
CH0140-V3A	AXLE	95*130*16
CH0332-V30-XX	AXLE	98*125.15/129.15*9.6
CH0148-P30	AXLE	98*125.15/133.8*9.6
CH0148-P30-XX	AXLE	98*125.15/133.8*9.6
CH0148-V30	AXLE	98*125.15/133.8*9.6
CH0148-V30-XX	AXLE	98*125.15/133.8*9.6
02-9801-V4A	AXLE	98.48*123.98*11.5/15
CH0361-N12	AXLE	100*130*14/17
CH0156-N10	AXLE	100*135*13/15
CH0102-N10	AXLE	100*135*14/15
CH0102-N10-XX	AXLE	100*135*14/15
CH0362-V32	AXLE	100*140*14/17

订货号	规格	尺寸
CH0236-V35	AXLE	100*140*15.5/20
CH0235-N10	AXLE	105*130*12
CH0305-V30	AXLE	105*140*18
CH0305-V30-XX	AXLE	105*140*18
CH0150-N10-FJ	AXLE	109.6*159.8*15/16.7
CH0185-N10-XX	AXLE	110*135*14.5
CH0077-N10	AXLE	110*140*14/17
CH0077-N12	AXLE	110*140*14/17
CH0275-V35	AXLE	110.23*145*10/12
CH0258-V30	AXLE	112*138.5*7.0
CH0257-V30	AXLE	112*138.5*8.5
CH0312-N10	AXLE	112*150*15
CH0111-N1T-XX	AXLE	113*152*17
CH0371-V30-SS	AXLE	114*135*7.5
CH0322-N10	AXLE	120*150*14.5/16
CH0117-N12	AXLE	120*160*17
CH0321-V35	AXLE	120*160*18/20
CH0190-N10	AXLE	121.8*150*13
CH0280-S15	AXLE	122*142*10/15
CH0280-V15	AXLE	122*142*10/15
CH0263-V3G-XX	AXLE	124.2*150*12
CH0293-V30	AXLE	125*142*8/9.2
CH0149-P30	AXLE	125*148.3/156*8.1/9.3
CH0149-P30-XX	AXLE	125*148.3/156*8.1/9.3
CH0149-V30	AXLE	125*148.3/156*8.1/9.3
CH0149-V30-XX	AXLE	125*148.3/156*8.1/9.3
CH0097-V32	AXLE	125*160*14/17
CH0281-P35-XX	AXLE	125*160*15.5/20
CH0281-V35	AXLE	125*160*15.5/20
CH0153-V30	AXLE	125*160*15/18
CH0075-N10	AXLE	127*160*15.5/17.5
CH0075-N30	AXLE	127*160*15.5/17.5
CH0075-V30-XX	AXLE	127*160*15.5/17.5
CH0031-V30	AXLE	130*170*14/17
CH0328-N10	AXLE	130*170*15
CH0161-V30	AXLE	130*170*18/20
CH0134-V31	AXLE	132*172*12
CH0095-V10-XX	AXLE	133*172*18/15
12022-N12	AXLE	133*190*14/28
CH0261-N10	AXLE	133.3*174*17
CH0176-V30	AXLE	135*165*14/17
CH0128-N10	AXLE	135*170*15.5
CH0072-N10	AXLE	135*175*15.5/20
CH0072-N20	AXLE	135*175*15.5/20
CH0253-V3A	AXLE	135*175*18
CH0329-N10	AXLE	135*175*18
CH0096-V3A	AXLE	135*175/205*18
CH0064-N10	AXLE	136.8*165*13

轮毂油封

订货号	规格	尺寸
CH0064-V30	AXLE	136.8*165*13
CH0126-V35	AXLE	139*175/205*11/16.3
CH0103-N10	AXLE	140*170*13.6/17.4
CH0103-N30	AXLE	140*170*13.6/17.4
CH0103-P30	AXLE	140*170*13.6/17.4
CH0268-V1A	AXLE	140*170*14.5/16
CH0268-V3A	AXLE	140*170*14.5/16
CH0214-V10-XX	AXLE	140*170*14/17
CH0214-V30-XX	AXLE	140*170*14/17
CH0238-V35	AXLE	140*170*15.5/20
CH0184-N30	AXLE	140*171.45*16/18.5
CH0266-N10	AXLE	141*190.5*18.66
CH0216-N10	AXLE	142*170*13.5/16
CH0027-N10	AXLE	142*170*15.5/17
CH0254-V30	AXLE	142.15*175.5*11.4
CH0115-V3A	AXLE	145*170*14.5/18
CH0084-H10	AXLE	145*175*13/15
CH0289-N10	AXLE	145*175*14.5/15.5
CH0104-V32	AXLE	145*175*14/17
CH0269-N20	AXLE	149.9*176*16
CH0076-N10	AXLE	150*180*14.5/16
CH0076-N30	AXLE	150*180*14.5/16
CH0076-V30	AXLE	150*180*14.5/16
CH0313-N10	AXLE	150*180*16
CH0245-N10	AXLE	150.15*178*13/16
CH0299-V3A	AXLE	155*190*14.5/16
CH0174-N10-XX	AXLE	155*190*14/19
CH0048-N20	AXLE	158*188*16
CH0048-V30	AXLE	158*188*16
CH0048-V30-XX	AXLE	158*188*16
CH0177-N10	AXLE	165*190*15.5/17
CH0173-N1T-XX	AXLE	165*194/244*17.5
CH0377-V3A	AXLE	165*195*18
CH0175-N10-XX	AXLE	167.8*198*13/17
CH0248-N10	AXLE	167.8*198*13/17
CH0316-N10	AXLE	170*200*16
CH0081-V30	AXLE	170*200*17.5/21
CH0068-N15	AXLE	170*210*25
CH0066-N10	AXLE	178*205*17
CH0298-V30	AXLE	178*205*17/20
CH0114-N10	AXLE	180*240*25
CH0350-N10	AXLE	190*215*15.5/17
CH0234-N10-XX	AXLE	190*220*16/18
CH0288-V3A	AXLE	190*230*14/17
CH0319-V30	AXLE	190*230*25
CH0314-N10	AXLE	200*230*16
CH0252-H10	AXLE	200*260*17.5
CH0389-V35	AXLE	210*250*25

订货号	规格	尺寸
CH0389-V35-XX	AXLE	210*250*25
CH0241-N10	AXLE	235*280*15/22.5
CH0212-N10	AXLE	25*52*12
CH0237-V3T-XX	AXLE	275*320*33.6
CH0232-V30	AXLE	275*325*33.6
12132-N10	AXLE	30*45*8
12088-N10	AXLE	30*50*8/14
12133-N10	AXLE	32*52*8
CH0296-N10	AXLE	35*65*14.5/17
12137-N10	AXLE	40*62*8
CH0085-V1A	AXLE	46*73/79*14.5/17
CH0074-N10	AXLE	48*72*10
CH0381-N10-SS	AXLE	53*79*13
CH0284-N10	AXLE	53.2*78*13/14
CH0356-N3A	AXLE	55*80*12.5/14
CH0356-V3A	AXLE	55*80*12.5/14
CH0142-N10	AXLE	60*90*13.5
CH0142-N10-XX	AXLE	60*90*13.5
CH0229-N10-XX	AXLE	60*94*16
CH0168-N10	AXLE	65*85*10
CH0304-V30	AXLE	65*90*13/14.5
CH0285-N10	AXLE	65*92*10/15
CH0181-V3A	AXLE	70*100*13.5/15
CH0062-V35	AXLE	70*90*13.5/14.5
CH0112-N10	AXLE	70*95*10.5
CH0098-N10	AXLE	73.2*106*13.5
CH0028-N10	AXLE	75*100*14
CH0113-V10-KIT	AXLE	76*125.5/136*19.4/20.5
CH0113-V12	AXLE	76*125.5/136*19.4/20.5
CH0182-N10	AXLE	76.2*95.25/104.77*16.8
CH0106-V12	AXLE	82.5*108/118.5*19/22
CH0195-P30-XX	AXLE	85*110/115*7.5/8.5
CH0195-V30-XX	AXLE	85*110/115*7.5/8.5
CH0306-V30	AXLE	85*120*10/21
CH0129-V30	AXLE	85*150*16.35/20
CH0294-V30	AXLE	85*150*16.35/24
CH0110-V3A	AXLE	87.26*120.76*15.4
CH0131-N12	AXLE	90*130*14/17
CH0131-N12-XX	AXLE	90*130*14/17
CH0131-P32	AXLE	90*130*14/17
CH0131-V12-XX	AXLE	90*130*14/17
CH0198-N12	AXLE	90*130*14/20
CH0140-V3A	AXLE	95*130*16
CH0332-V30-XX	AXLE	98*125.15/129.15*9.6
CH0148-P30	AXLE	98*125.15/133.8*9.6
CH0148-P30-XX	AXLE	98*125.15/133.8*9.6
CH0148-V30	AXLE	98*125.15/133.8*9.6
CH0148-V30-XX	AXLE	98*125.15/133.8*9.6
02-9801-V4A	AXLE	98.48*123.98*11.5/15

服務源自專業...

訂货号	规格	尺寸
CH0375-N10	AXLE	1.250*2.402*0.551
CH0265-N10	AXLE	1.614*3.000*0.650
CH0282-N10	AXLE	1.615*2.400*0.512/0.650
CH0336-N10-XX	AXLE	1.750*3.867*0.312
CH0368-N10-XX	AXLE	1.800*3.688*0.500
A1807-N10	AXLE	100*135*14/15
CH0019-N10	AXLE	120*146*19.56
CH0056-N10-XX	AXLE	149.9*176*13.5/16
CH0056-N30-XX	AXLE	149.9*176*13.5/16
CH0058-N15	AXLE	150*176*14.5/19.5
CH0337-N10-XX	AXLE	2.000*3.000*0.500
CH0053	AXLE	2.250*3.000*0.800
CH0352-N10	AXLE	2.250*3.372*0.475
T08102	AXLE	2.500*3.500*0.500
CH0049	AXLE	2.750*3.779*0.762
CH0382-P10	AXLE	2.854*4.246*0.740
CH0135-V10-XX	AXLE	2.875*3.875*0.492
CH0189-N10	AXLE	2.875*3.875*0.500
CH0189-N12	AXLE	2.875*3.875*0.500
CH0189-N17	AXLE	2.875*3.875*0.500
58758N150	AXLE	2.875*3.875*3.880*0.500
CH0384-N16	AXLE	2.875*4.175*0.822
CH0308-N10	AXLE	2.940*3.750*0.470/0.530
CH0341-N10	AXLE	2.955*3.875*0.488
CH0358-V30	AXLE	3.000*4.339*0.949
CH0353-N14	AXLE	3.125*4.500*0.605
06163-N12	AXLE	3.125*4.500*0.672
06163-N15	AXLE	3.125*4.500*0.672
CH0383-N16	AXLE	3.125*4.625*0.605
CH0340-N10	AXLE	3.250*4.500*0.605
CH0088-N12	AXLE	3.250*4.501*0.672
CH0145-N16	AXLE	3.437*4.755*0.699
CH0145-N16-XX	AXLE	3.437*4.755*0.699
CH0023-N10	AXLE	3.438*4.757*0.700
CH0039-N15	AXLE	3.438*4.757*0.859
CH0119-N10	AXLE	3.500*4.543*0.788
CH0122-N10	AXLE	3.500*4.547*0.900
CH0355-N10	AXLE	3.500*4.751*0.605
CH0503-N10	AXLE-704	3.500*4.841*0.919
CH0302-V30	AXLE	3.500*4.841*0.919
CH0503-H1H	AXLE-804	3.500*4.841*0.919
CH0003-N10	AXLE	3.500*4.842*0.903
CH0003-N30	AXLE	3.500*4.842*0.903
CH0013-N12-XX	AXLE	3.500*4.842*0.904
CH0013-N15	AXLE	3.500*4.842*0.904
CH0013-N15-NEW	AXLE	3.500*4.842*0.904
CH0013-N16-XX	AXLE	3.500*4.842*0.904
CH0013-N35	AXLE	3.500*4.842*0.904
CH0043-N10	AXLE	3.500*4.842*0.925
CH0033-N12	AXLE	3.574*4.757*0.548
CH0033-N15	AXLE	3.574*4.757*0.548
CH0025-N10	AXLE	3.625*4.810*0.921
CH0301-H15	AXLE-L	3.748*4.720*0.550/0.815
06538-N10	AXLE	3.875*5.129*0.844

訂货号	规格	尺寸
06538-N12	AXLE	3.875*5.129*0.844
06538-N15	AXLE	3.875*5.129*0.844
CH0093-N16	AXLE	3.875*5.376*0.905
CH0035-N16	AXLE	3.875*5.500*0.938
CH0046-N10	AXLE	3.875*5.690*0.875
CH0505-N10	AXLE-703	3.875*5.690*0.927
CH0505-H1H	AXLE-803	3.875*5.690*0.927
CH0029-N16	AXLE	3.875*5.691*0.938
CH0029-N16-XX	AXLE	3.875*5.691*0.938
130528-N15	AXLE	3.875*5.696*0.875
CH0036-N16	AXLE	3.875*5.696*0.875
CH0327-N10	AXLE	3.937*5.372*1.015
CH0091-N12	AXLE	3.938*5.505*0.750
CH0091-N16	AXLE	3.938*5.505*0.750
0713-N10	AXLE	3.999*5.747*0.960
CH0061-N15-XX	AXLE	4.000*5.126*1.047
07114-N12	AXLE	4.000*5.375*1.000
CH0012-N16	AXLE	4.000*5.625*0.605
CH0009-N15	AXLE	4.000*5.626*0.700
CH0506-N10	AXLE-708	4.000*5.750*1.068
CH0506-H1H	AXLE-808	4.000*5.750*1.068
CH0015-N15	AXLE	4.000*5.754*1.079
CH0015-N15-XX	AXLE	4.000*5.754*1.079
CH0015-N35	AXLE	4.000*5.754*1.079
04741-N12	AXLE	4.000*5.757*0.866
06607-N12	AXLE	4.000*5.757*0.930
CH0143-N10	AXLE	4.000*5.757*0.930
CH0143-N10-XX	AXLE	4.000*5.757*0.930
CH0069-N16	AXLE	4.125*5.375*0.605
CH0354-N15	AXLE	4.166*5.500*0.605
CH0127-N10-XX	AXLE	4.250*6.000*0.637
A5813-80	AXLE	4.250*6.000*0.750
CH0101-N10-XX	AXLE	4.250*6.000*0.750
CH0147-N10	AXLE	4.250*6.000*0.766
A5901	AXLE	4.250*6.000*1.000
CH0024-N10	AXLE	4.250*6.000*1.000
CH0026	AXLE	4.250*6.000*1.000
0723-N10	AXLE	4.250*6.000*1.062
CH0158-N10	AXLE	4.250*6.008*0.680
CH0020-N10	AXLE	4.250*6.008*0.680
CH0502-H1H	AXLE-801	4.250*6.008*0.974
CH0502-N10	AXLE-701	4.250*6.008*0.974
CH0267-H10	AXLE	4.250*6.008*0.974
CH0045-N10	AXLE	4.250*6.008*1.000
CH0045-N10-XX	AXLE	4.250*6.008*1.000
CH0219-N10	AXLE	4.250*6.008*1.142
CH0219-N10-XX	AXLE	4.250*6.008*1.142
CH0219-N10	AXLE	4.250*6.008*1.142
CH0001-N15	AXLE	4.250*6.009*0.984
CH0001-N16-XX	AXLE	4.250*6.009*0.984
CH0001-N35	AXLE	4.250*6.009*0.984
T04039	AXLE	4.250*6.048*0.680
T04039FX	AXLE	4.250*6.048*0.680
T04039TQ	AXLE	4.250*6.048*0.680

轮毂油封

订货号	规格	尺寸
CH0054-N10	AXLE	4.250*6.250*1.188
CH0054-N10-XX	AXLE	4.250*6.250*1.188
CH0509-H1H	AXLE-807	4.250*6.250*1.240
CH0509-N10	AXLE-707	4.250*6.250*1.240
CH0016-N15-XX	AXLE	4.250*6.254*1.250
CH0225-N16	AXLE	4.375*5.748*0.605
CH0226-N12	AXLE	4.375*5.751*0.945
CH0118-N10	AXLE	4.375*5.751*0.995
CH0215-N15	AXLE	4.375*5.751*1.016
CH0215-N35	AXLE	4.375*5.751*1.016
04747-N12	AXLE	4.375*5.763*0.930
CH0508-H1H	AXLE-805	4.375*5.905*0.990
CH0508-N10	AXLE-705	4.375*5.905*0.990
CH0060-N15	AXLE	4.375*5.905*1.000
CH0065-N12-XX	AXLE	4.375*5.905*1.000
CH0065-N15-XX	AXLE	4.375*5.905*1.000
CH0065-N16-XX	AXLE	4.375*5.905*1.000
CH0078-N15	AXLE	4.375*6.003*1.047
CH0018-N16	AXLE	4.375*6.251*0.605
CH0018-N16-XX	AXLE	4.375*6.251*0.605
CH0092-N10	AXLE	4.500*5.374*0.905
CH0092-N16	AXLE	4.500*5.374*0.905
CH0067-N10-XX	AXLE	4.500*5.750*0.960
CH0507-H1H	AXLE-810	4.500*5.750*1.006
CH0507-N10	AXLE-710	4.500*5.750*1.006
CH0059-N15	AXLE	4.500*5.751*1.016
CH0017-N15	AXLE	4.500*5.876*0.984
CH0017-N15-XX	AXLE	4.500*5.876*0.984
CH0071-N10	AXLE	4.500*6.251*6.265*0.610
CH0044-N15	AXLE	4.500*6.254*1.047
0744-N10	AXLE	4.602*5.753*1.015
12028-N12	AXLE	4.606*6.311*1.141
CH0109-N10	AXLE	4.625*5.999*0.840
CH0109-N10-XX	AXLE	4.625*5.999*0.840
CH0007-N16	AXLE	4.625*5.999*1.000
T01056	AXLE	4.625*5.999*1.000
0743-N10	AXLE	4.625*6.000*1.063
307-0743	AXLE	4.625*6.001*0.912
CH0063-N10	AXLE	4.625*6.001*0.912
CH0501-N10	AXLE-702	4.625*6.001*1.000
CH0047-N10	AXLE	4.625*6.001*1.000
CH0047-N10-XX	AXLE	4.625*6.001*1.000
CH0501-H1H	AXLE-802	4.625*6.001*1.000
CH0002-N15-HP	AXLE	4.625*6.001*1.063
CH0002-N12	AXLE	4.625*6.001*1.063
CH0002-N15	AXLE	4.625*6.001*1.063
CH0002-N15-XX	AXLE	4.625*6.001*1.063
CH0002-N16-XX	AXLE	4.625*6.001*1.063
CH0260-H10	AXLE	4.625*6.001*1.063
CH0260-H10-XX	AXLE	4.625*6.001*1.063
CH0260-N10	AXLE	4.625*6.001*1.063
04751-N12-XX	AXLE	4.625*6.006*0.846
04751-N12	AXLE	4.625*6.006*0.912
CH66175-P15	AXLE-L	4.646*5.751*0.500
CH66369-P1T-KIT	AXLE-L	4.646*5.751*0.525/0.728

订货号	规格	尺寸
CH0271-N10	AXLE	4.750*6.001*1.063
CH0021-N12	AXLE	4.762*6.315*1.160
CH0021-N16	AXLE	4.762*6.315*1.160
CH0022-N15	AXLE	4.765*6.251*0.605
CH0022-N16	AXLE	4.765*6.251*0.605
CH0022-N16-XX	AXLE	4.765*6.251*0.605
CH0032-N10	AXLE	4.765*6.311*1.078
CH0032-N10-XX	AXLE	4.765*6.311*1.078
CH0032-N12	AXLE	4.765*6.311*1.078
CH0030-N15	AXLE	4.765*6.311*1.187
CH0034-N16	AXLE	4.765*6.999*1.250
CH0089-N12	AXLE	4.766*6.001*1.063
CH0272-H10	AXLE	4.766*6.254*0.795
CH0272-N10	AXLE	4.766*6.254*0.795
CH0005-H15	AXLE	4.766*6.311*1.125
CH0005-N15	AXLE	4.766*6.311*1.125
CH0005-N15-XX	AXLE	4.766*6.311*1.125
CH0005-N16	AXLE	4.766*6.311*1.125
CH0005-N16-XX	AXLE	4.766*6.311*1.125
CH0037-N15	AXLE	4.766*6.312*1.250
CH0037-N15-XX	AXLE	4.766*6.312*1.250
CH0213-N12	AXLE	4.766*6.315*1.160
CH0090-N12	AXLE	4.766*6.500*1.063
CH0295-N1T-XX	AXLE	4.767*6.308*1.115
CH0154-V10-XX	AXLE	4.767*6.308*1.378
A124-007-N10	AXLE	4.767*6.308*1.420
CH0004-N10	AXLE	4.767*6.308*1.420
CH0004-N10-XX	AXLE	4.767*6.308*1.420
CH0087-N10	AXLE	4.767*6.308*1.420
CH0087-N10-XX	AXLE	4.767*6.308*1.420
CH0087-N30	AXLE	4.767*6.308*1.420
CH0504-N10	AXLE-709	4.767*6.312*1.115
CH0270-H10	AXLE	4.767*6.312*1.115
CH0283-H10	AXLE	4.767*6.312*1.115
CH0303-V30	AXLE	4.767*6.312*1.115
CH0601-H10	AXLE	4.767*6.312*1.115
CH0504-H1H	AXLE-809	4.767*6.312*1.115
CH0116-V36-XX	AXLE	4.875*5.999*0.625
CH0011-N15	AXLE	4.875*6.001*0.875
CH0179-N16	AXLE	4.875*6.500*1.000
CH0239-N10	AXLE	4.875*6.500*1.000
CH0057-N15	AXLE	4.875*6.503*1.063
CH0057-N15-XX	AXLE	4.875*6.503*1.063
CH0193-V3W	AXLE	5.000*7.500*0.750/0.875
CH0193-V3W-XX	AXLE	5.000*7.500*0.750/0.875
CH0073-N16	AXLE	5.250*7.375*1.000
CH0006-N15-XX	AXLE	5.250*7.376*0.945
CH0228-N16-XX	AXLE	5.500*7.250*1.187
CH0309-H10	AXLE	5.500*7.500*0.563
CH0309-H10-XX	AXLE	5.500*7.500*0.563
CH0123-N10	AXLE	5.512*6.693*0.591
CH0070-N16	AXLE	5.625*7.186*0.906
CH0240-N10	AXLE	5.640*7.501*0.413/0.605
CH0287-H10-XX	AXLE	6.625*8.007*0.668
CH0199-V3W	AXLE	7.375*9.625*1.000

端面密封V-RING

端面密封也叫水封，用于旋转运动的端面密封，防止灰尘，水以及其他污物侵入轴承部位或密封系统。基本形式为VA、VS，特殊条件可选VE、VL型。产品常规材质为NBR丁腈橡胶，也可根据使用环境需要，提供氟橡胶（viton）产品。

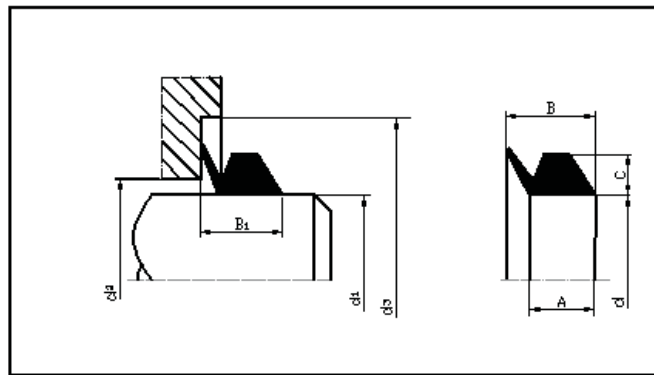

VS型

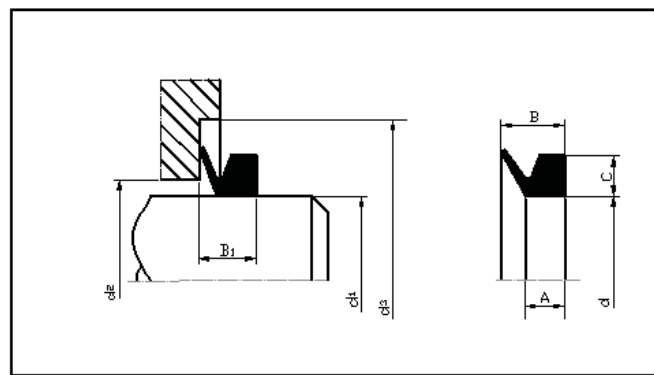

VA型

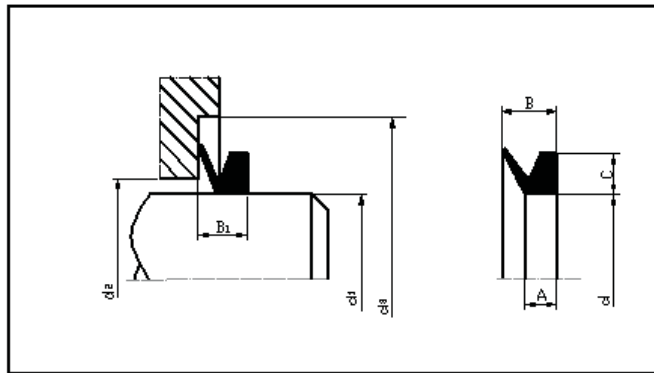

VL型

端面密封

VS系列

规格型号	适用轴径	内径(d)	外径(d+2c)	高度(A/B)
VS-005	4.50-5.50	4	8	3.9/5.2
VS-006	5.50-6.50	5	9	3.9/5.2
VS-007	6.50-8.00	6	10	3.9/5.2
VS-008	8.00-9.00	7	11	5.6/7.7
VS-010	9.50-11.5	9	15	5.6/7.7
VS-012	11.5-13.5	10	16.5	5.6/7.7
VS-014	13.5-15.5	12	18.5	5.6/7.7
VS-016	15.5-17.5	14	20	5.6/7.7
VS-018	17.5-19.0	16	22	7.9/10.5
VS-020	19.0-21.0	18	26	7.9/10.5
VS-022	21.0-24.0	20	28	7.9/10.5
VS-025	24.0-27.0	22	30	7.9/10.5
VS-028	27.0-29.0	25	33	7.9/10.5
VS-030	29.0-31.0	27	35	7.9/10.5
VS-032	31.0-33.0	29	37	7.9/10.5
VS-035	33.0-36.0	31	39	7.9/10.5
VS-038	36.0-38.0	34	42	7.9/10.5
VS-040	38.0-43.0	36	46	9.5/13.0
VS-045	43.0-48.0	40	50	9.5/13.0
VS-050	48.0-53.0	45	55	9.5/13.0
VS-055	53.0-58.0	49	59	9.5/13.0
VS-060	58.0-63.0	54	64	9.5/13.0
VS-065	63.0-68.0	58	68	9.5/13.0
VS-070	68.0-73.0	63	75	11.3/15.5
VS-075	73.0-78.0	67	79	11.3/15.5
VS-080	78.0-83.0	72	84	11.3/15.5
VS-085	83.0-88.0	76	88	11.3/15.5
VS-090	88.0-93.0	81	93	11.3/15.5
VS-095	93.0-98.0	85	97	11.3/15.5
VS-100	98.0-105.0	90	102	11.3/15.5
VS-110	105-115	99	113	13.1/18.0
VS-120	115-125	108	122	13.1/18.0
VS-130	125-135	117	131	13.1/18.0
VS-140	135-145	126	140	13.1/18.0
VS-150	145-155	135	149	13.1/18.0
VS-160	155-165	144	160	15.0/20.5
VS-170	165-175	153	169	15.0/20.5
VS-180	175-185	162	178	15.0/20.5
VS-190	185-195	171	187	15.0/20.5
VS-199	195-210	180	196	15.0/20.5

服務源自專業...

VA系列

规格型号	适用轴径	内径(d)	外径(d+2c)	高度(A/B)
VA-003	2.7-3.5	2.5	5.5	2.1-3
VA-004	3.5-4.5	3.2	7.2	2.4/3.7
VA-005	4.5-5.5	4	8	2.4/3.7
VA-006	5.5-6.5	5	9	2.4/3.7
VA-007	6.5-8.0	6	10	2.4/3.7
VA-008	8.0-9.5	7	11	2.4/3.7
VA-010	9.5-11.5	9	15	3.4/5.5
VA-012	11.5-12.5	10.5	16.5	3.4/5.5
VA-014	13.5-15.5	12.5	18.5	3.4/5.5
VA-016	15.5-17	14	20	3.4/5.5
VA-018	17.5-19	16	22	3.4/5.5
VA-020	19-21	18	26	4.7/7.5
VA-022	21-24	20	28	4.7/7.5
VA-025	24-27	22	30	4.7/7.5
VA-028	27-29	25	33	4.7/7.5
VA-030	29-31	27	35	4.7/7.5
VA-032	31-33	29	37	4.7/7.5
VA-035	33-36	31	39	4.7/7.5
VA-038	36-38	34	42	4.7/7.5
VA-040	38-43	36	46	5.5/9
VA-045	43-48	40	50	5.5/9
VA-050	48-53	45	55	5.5/9
VA-055	53-58	49	59	5.5/9
VA-060	58-63	54	64	5.5/9
VA-065	63-68	58	68	5.5/9
VA-070	68-73	63	75	6.8/11
VA-075	73-78	67	79	6.8/11
VA-080	78-83	72	84	6.8/11
VA-085	83-88	76	88	6.8/11
VA-090	88-93	81	93	6.8/11
VA-095	93-98	85	97	6.8/11
VA-100	98-105	90	102	6.8/11
VA-110	105-115	99	113	7.9/12.8
VA-120	115-125	108	122	7.9/12.8
VA-130	125-135	117	131	7.9/12.8
VA-140	135-145	126	140	7.9/12.8
VA-150	145-155	135	149	7.9/12.8
VA-160	155-165	144	160	9/14.5
VA-170	165-175	153	169	9/14.5
VA-180	175-185	162	178	9/14.5
VA-190	185-195	171	187	9/14.5
VA-199	195-210	180	196	9/14.5
VA-200	190-210	180	210	14.3-25

端面密封

VA系列

规格型号	适用轴径	内径(d)	外径(d+2c)	高度(A/B)
VA-220	210-235	198	228	14.3-25
VA-250	235-265	225	255	14.3-25
VA-275	265-290	247	277	14.3-25
VA-300	290-310	270	300	14.3-25
VA-325	310-335	292	322	14.3-25
VA-350	335-365	315	345	14.3-25
VA-375	365-390	337	367	14.3-25
VA-400	390-430	360	390	14.3-25
VA-450	430-480	405	435	14.3-25
VA-500	480-530	450	480	14.3-25
VA-550	530-580	495	525	14.3-25
VA-600	580-630	540	570	14.3-25
VA-650	630-665	600	630	14.3-25
VA-700	665-705	630	660	14.3-25
VA-725	705-745	670	700	14.3-25
VA-750	745-785	705	735	14.3-25
VA-800	785-830	745	775	14.3-25
VA-850	830-875	785	815	14.3-25
VA-900	875-920	825	855	14.3-25
VA-950	920-965	865	895	14.3-25
VA-1000	965-1015	910	940	14.3-25
VA-1050	1015-1065	955	985	14.3-25
VA-1100	1065-1115	1000	1030	14.3-25
VA-1150	1115-1165	1045	1075	14.3-25
VA-1200	1165-1215	1090	1120	14.3-25
VA-1250	1215-1270	1135	1165	14.3-25
VA-1300	1270-1320	1180	1210	14.3-25
VA-1350	1320-1370	1225	1255	14.3-25
VA-1400	1370-1420	1270	1300	14.3-25
VA-1450	1420-1470	1315	1345	14.3-25
VA-1500	1470-1520	1360	1390	14.3-25
VA-1550	1520-1570	1405	1435	14.3-25
VA-1600	1570-1620	1450	1480	14.3-25
VA-1650	1620-1670	1495	1510	14.3-25
VA-1700	1670-1720	1540	1570	14.3-25
VA-1750	1720-1770	1585	1615	14.3-25
VA-1800	1770-1820	1630	1660	14.3-25
VA-1850	1820-1870	1675	1705	14.3-25
VA-1900	1870-1920	1720	1750	14.3-25
VA-1950	1920-1970	1765	1795	14.3-25
VA-2000	1970-2020	1810	1840	14.3-25

服務源自專業...

VL系列

规格型号	适用轴径	内径(d)	外径(d+2c)	高度(A/B)
VL-110	105-115	99	112	6/10.5
VL-120	115-125	108	121	6/10.5
VL-130	125-135	117	130	6/10.5
VL-140	135-145	126	139	6/10.5
VL-150	145-155	135	148	6/10.5
VL-160	155-165	144	157	6/10.5
VL-170	165-175	153	166	6/10.5
VL-180	175-185	162	175	6/10.5
VL-190	185-195	171	183	6/10.5
VL-200	195-210	182	194	6/10.5
VL-220	210-233	198	210	6/10.5
VL-250	233-260	225	237	6/10.5
VL-275	260-285	247	259	6/10.5
VL-300	285-310	270	282	6/10.5
VL-325	310-335	292	304	6/10.5
VL-350	335-365	315	327	6/10.5
VL-375	365-385	337	349	6/10.5
VL-400	385-410	360	372	6/10.5
VL-425	410-440	382	394	6/10.5
VL-450	440-475	405	417	6/10.5
VL-500	475-510	450	462	6/10.5
VL-525	510-540	472	484	6/10.5
VL-550	540-575	495	507	6/10.5
VL-600	575-625	540	552	6/10.5

密封盖(端盖)

密封盖，也叫端盖或闷盖油封。多用于齿轮箱和减速机箱体。防止灰尘，污物侵入运动部位。产品材质以NBR丁腈橡胶为主。

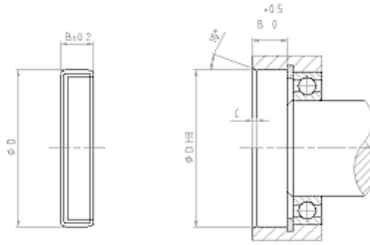

型号	规格
CAP	22*5
CAP	24*7
CAP	25*4
CAP	25*5
CAP	26*4
CAP	28*5
CAP	28*7
CAP	30*8
CAP	32*6
CAP	32*7
CAP	32*8
CAP	35*6.5
CAP	35*7
CAP	35*8
CAP	37*7
CAP	37*10
CAP	40*7
CAP	40*10
CAP	42*7
CAP	42*8
CAP	42*9.5
CAP	47*6.5
CAP	47*7
CAP	47*8
CAP	47*10
CAP	49.5*11
CAP	50*7
CAP	50*13.5
CAP	52*6.5
CAP	52*7
CAP	52*8
CAP	52*10
CAP	55*7
CAP	55*8
CAP	55*10
CAP	60*7
CAP	60*8
CAP	60*10
CAP	62*7

型号	规格
CAP	62*8
CAP	62*10
CAP	62*12
CAP	65*8
CAP	68*8
CAP	70*8
CAP	70*9
CAP	70*10
CAP	72*7
CAP	72*9
CAP	72*10
CAP	75*7
CAP	75*9
CAP	80*7
CAP	80*8
CAP	80*10
CAP	80*12
CAP	85*10
CAP	85*12
CAP	90*8
CAP	90*10
CAP	90*12
CAP	92*10
CAP	92*12
CAP	100*10
CAP	100*12
CAP	105*10
CAP	110*12
CAP	115*12
CAP	120*12
CAP	125*12
CAP	130*12
CAP	140*10
CAP	140*15
CAP	150*15
CAP	160*15
CAP	200*13
CAP	225*14
CAP	240*15

服務源自專業...

高压油封

这是一种源于日本NOK设计的骨架油封。一般普通骨架油封。基本不能承受压力，而TCN/TCV系列骨架油封承受最高压力可达10KG。此系列油封多用于工程机械、船舶机械设备。产品材质以NBR丁腈橡胶为主。



规格	轴径(d)	外径(D)	高度(h)	NOK代号
TCN	20	35	8	AP1013
TCN	20	40	11	AP1251
TCN	25	45	11	AP1338
TCN	28	48	11	AP1563
TCN	30	50	11	AP1709
TCN	35	55	11	AP2085
TCN	38	58	11	AP2240
TCN	40	62	11	AP2388
TCN	42	65	12	AP2507
TCN	45	62	12	AP2653
TCN	45	65	10	AP2658
TCN	45	68	12	AP2668
TCN	48	70	12	AP2791
TCN	50	68	12	AP2850
TCN	50	72	12	AP2864
TCN	52	75	9	AP2965
TCN	55	78	12	AP3055
TCN	58	80	12	AP3219
TCN	60	82	12	AP3222
TCN	62	85	12	AP3297
TCN	65	90	13	AP3409
TCN	68	95	13	AP3463
TCN	70	95	13	AP3527
TCN	75	100	13	AP3618
TCN	80	105	13	AP3744
TCN	85	110	13	AP3842
TCN	90	115	13	AP3932
TCN	95	120	13	AP3994
TCN	95	120	15	AP3995
TCN	100	125	13	AP4063
TCN	105	135	14	AP4153
TCN	110	140	14	AP4212
TCN	120	150	14	AP4346
TCN	125	155	14	AP4399
TCN	130	160	14	AP4451
TCN	140	170	14	AP4542
TCN	150	180	14	AP4624
TCN	170	200	16	AP4795
TCN	190	225	16	AP4983

筒型轴承油封

该系列产品为配合德国INA和日本IKO生产的滚针轴承及直线轴承用密封而开发。一般为薄型骨架油封，不带弹簧，形式以VC.VB为主。材质以NBR丁腈橡胶为主。该类油封多用于烟草机械、印刷机械及纺织机械等轻工设备。

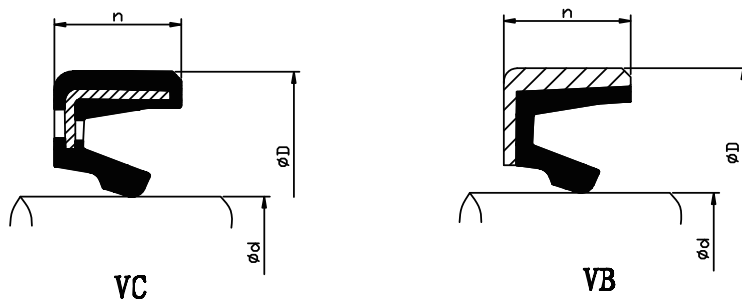

内径 (d)	外径 (D)	宽度 (n)	INA规格		IKO规格		WOOGOR规格	
			单唇	双唇	单唇	双唇	VC	VB
4	8	2	G				☆	
5	9	2	G				☆	
5	10	2	G				☆	
6	10	2	G				☆	
6	12	2	G				☆	★
7	11	2	G				☆	
7	14	2	G				☆	
8	12	3	G		OS		☆	
8	15	3	G	SD	OS			★
9	13	3	G		OS		☆	★
9	16	3	G	SD	OS		☆	
10	14	3	G		OS		☆	
10	17	3	G	SD	OS		☆	★
10	18	4					☆	★
10	20	4					☆	
12	16	3	G		OS		☆	
12	18	3	G	SD	OS		☆	★
12	19	3	G	SD	OS		☆	★
13	19	3	G	SD	OS		☆	★
14	20	3	G	SD	OS	DS	☆	★
14	20	4						★
14	21	3	G	SD			☆	
14	22	4	G	SD	OS	DS	☆	★
15	21	3	G	SD	OS	DS	☆	★
15	22	3			OS	DS	☆	★
15	23	3	G	SD	OS	DS	☆	★
16	22	3	G	SD	OS	DS	☆	★
16	22	4	G	SD			☆	★
16	24	3	G	SD	OS	DS	☆	★
16	24	4					☆	★
16	25	3	G	SD			☆	★
16	28	5			OS	DS	☆	★
17	23	3	G	SD	OS	DS	☆	★
17	24	3			OS	DS	☆	★
17	25	3	G	SD	OS	DS	☆	★
18	24	3	G	SD	OS	DS	☆	★

服務源自專業...

内径 (d)	外径 (D)	宽度 (n)	INA规格		IKO规格		WOOGOR规格	
			单唇	双唇	单唇	双唇	VC	VB
18	24	4	G	SD			☆	★
18	25	3			OS	DS	☆	★
18	26	4	G	SD	OS	DS	☆	★
19	27	4	G	SD	OS	DS	☆	★
20	26	3					☆	
20	26	4	G	SD	OS	DS	☆	★
20	26	5					☆	
20	27	4			OS	DS	☆	★
20	28	4	G	SD	OS	DS	☆	★
20	30	4			OS	DS	☆	★
20	30	5					☆	
20	32	4			OS	DS	☆	★
20	32	6			OS	DS	☆	
21	29	4	G	SD	OS	DS	☆	★
22	28	4	G	SD	OS	DS	☆	★
22	29	4			OS	DS	☆	★
22	30	4	G	SD	OS	DS	☆	★
24	32	4	G	SD	OS	DS	☆	★
25	32	4	G	SD	OS	DS	☆	★
25	33	4	G	SD	OS	DS	☆	★
25	35	4	G	SD			☆	★
25	35	5					☆	
25	35	6			OS	DS	☆	
25	37	6			OS	DS	☆	
26	34	4	G	SD	OS	DS	☆	★
27	35	4					☆	
28	35	3					☆	
28	35	4	G	SD	OS	DS	☆	★
28	37	4	G	SD	OS	DS	☆	★
28	39	6			OS	DS	☆	
28	40	6			OS	DS	☆	
29	37	4		SD			☆	★
29	38	4	G	SD	OS	DS	☆	
30	37	4	G	SD	OS	DS	☆	★
30	38	5					☆	
30	40	4	G	SD	OS	DS	☆	
30	40	5					☆	
30	42	4					☆	
30	42	6			OS	DS	☆	
32	42	4	G	SD	OS	DS	☆	
32	45	4	G	SD			☆	
32	45	6			OS	DS	☆	

筒型轴承油封

内径 (d)	外径 (D)	宽度 (n)	INA规格		IKO规格		WOOGOR规格	
			单唇	双唇	单唇	双唇	VC	VB
35	42	4	G	SD	OS	DS	☆	
35	45	4	G	SD	OS	DS	☆	
35	47	6			OS	DS	☆	
37	47	4	G	SD	OS	DS	☆	
38	48	4	G	SD	OS	DS	☆	
38	50	6			OS	DS	☆	
40	47	4	G	SD	OS	DS	☆	
40	47	5					☆	
40	48	4					☆	
40	45	4					☆	
40	50	4	G	SD	OS	DS	☆	
40	50	5					☆	
40	52	5	G	SD			☆	
40	52	6			OS	DS	☆	
40	55	6			OS	DS	☆	
42	52	4	G	SD			☆	
42	55	7			OS	DS	☆	
43	53	4	G	SD			☆	
45	52	4	G	SD	OS	DS	☆	★
45	55	4	G	SD	OS	DS	☆	★
45	62	7			OS	DS	☆	
45	65	5					☆	
48	62	7			OS	DS	☆	
50	58	4	G	SD	OS	DS	☆	★
50	62	4			OS	DS	☆	
50	62	5	G	SD			☆	
50	65	7			OS	DS	☆	
52	68	7			OS	DS	☆	
55	63	5	G				☆	
55	67	4			OS	DS	☆	
55	68	7			OS	DS	☆	
55	72	7			OS		☆	
58	72	7			OS	DS	☆	
60	72	4			OS	DS	☆	
60	78	7			OS	DS	☆	
62	74	4			OS	DS	☆	
62	74	7			OS	DS	☆	
63	80	7			OS	DS	☆	
65	77	4			OS	DS	☆	
65	85	7			OS	DS	☆	
68	85	7			OS	DS	☆	
70	78	5	G				☆	
70	82	4			OS	DS	☆	

轴承箱油封—ZF 系列

这是日本NOK公司基于轴承箱（双列调心轴承222**、223**系列轴承箱）密封需要研发可替代毛毡和迷宫密封装置的产品。在保证密封效果的前提下，使轴承箱的结构更简化。

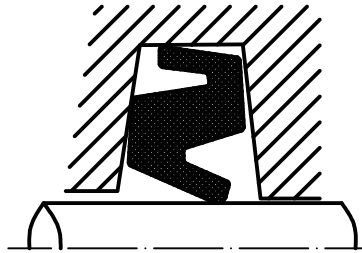

ZF Seal

型号	适用轴径	部件编号(NOK)	轴承箱规格
ZF-001	10	AZ 0264 EO	—
ZF-002	12	AZ 0373 EO	—
ZF-003	15	AZ 0589 FO	—
ZF-004	17	AZ 0733 FO	SN504 SN604
ZF-005	19.05	AZ 0906 EO	S505E S605E
ZF-005	20	AZ 0992 GO	SN505 SN605
ZF-006	25	AZ 1304 HO	SN506 SN606
ZF-007	28.58	AZ 1602 EO	S507S S607S
ZF-007	30	AZ 1670 HO	SN507 SN607
ZF-007	30.16	AZ 1670 HO	S507A S607
ZF-008	31.75	AZ 1833 EO	S508E S608E
ZF-008	34.92	AZ 2045 GO	S508S S608S
ZF-008	35	AZ 2045 GO	SN508 SN608
ZF-009	38.1	AZ 2275 EO	SS509E S609E
ZF-009	40	AZ 2347 GO	SN509 SN609
ZF-010	44.45	AZ 2578 EO	S510E S610E
ZF-010	45	AZ 2636 GO	SN510 SN610
ZF-011	49.21	AZ 2845 FO	S511A S611A
ZF-011	50	AZ 2845 FO	SN511 SN611
ZF-011	50.8	AZ 2914 EO	S511E S611E
ZF-012	55	AZ 3038 GO	SN512 SN612
ZF-013	57.15	AZ 3126 EO	S513E S613E
ZF-013	60	AZ 3199 GO	SN513 SN613
ZF-013	60.32	AZ 3199 GO	—
ZF-015	63.5	AZ 3334 EO	S515E S615E

轴承箱油封

型号	适用轴径	部件编号(NOK)	轴承箱规格
ZF-015	65	AZ 3388 FO	SN525 SN616
ZF-016	69.85	AZ 3508 FO	S516E S616E
ZF-016	70	AZ 3508 FO	SN516 SN616
ZF-017	74.61	AZ 3606 FO	S517A S617A
ZF-017	75	AZ 3606 FO	SN517 SN617
ZF-018	79.38	AZ 3727 FO	S518S S618S
ZF-018	80	AZ 3727 FO	SN518 S618
ZF-019	85	AZ 3832 FO	S619
ZF-020	88.9	AZ 3887 EO	S520E S620E
ZF-020	90	AZ 3923 FO	SN520 S620
ZF-021	95	AZ 3987 EO	—
ZF-021	95.25	AZ 3987 EO	—
ZF-022	100	AZ 4061 FO	SN522 S622
ZF-022	100.01	AZ 4061 FO	S522A S622A
ZF-023	105	AZ 4149 EO	—
ZF-024	110	AZ 4206 FO	SN524 S624
ZF-026	114.3	AZ 4276 FO	S526E S626E
ZF-026	115	AZ 4276 FO	SN526 SN626
ZF-027	120	AZ 4343 EO	—
ZF-028	125	AZ 4397 EO	SN528 S628
ZF-028	125.41	AZ 4397 EO	S528A S628A
ZF-029	130	AZ 4448 EO	—
ZF-030	135	AZ 4497 FO	SN530 S630
ZF-032	139.7	AZ 4549 EO	S532E S632E
ZF-032	140	AZ 4549 EO	SN532 S632
ZF-034	150	AZ 4629 FO	SD534 SD3134
ZF-036	160	AZ 4716 FO	SD536 SD3136
ZF-038	170	AZ 4899 FO	SD538 SD3138
ZF-040	180	AZ 4902 FO	SD540 SD3140
ZF-042	190	AZ 4980 EO	—
ZF-044	200	AZ 5064 EO	SD544 SD3144
ZF-046	210	AZ 5137 FO	—
ZF-048	220	AZ 5213 EO	SD548 SD3148
ZF-052	240	AZ 5355 EO	SD552 SD3152
ZF-054	250	AZ 5409 EO	—
ZF-056	260	AZ 5466 EO	SD556 SD3156
ZF-060	280	AZ 5570 FO	SD560 SD3160
ZF-064	300	AZ 5638 FO	SD564 SD3164
ZF-068	320	AZ 5716 FO	—
ZF-080	380	AZ 5887 EO	—

轴承箱油封-TSNG系列

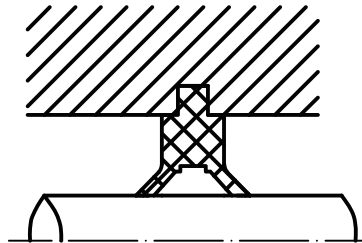

TSNG Seal

密封件型号	密封件型号	适用轴径	轴承箱型号
TSNG-507	TSNG-607	30	SNG 507-606
TSNG-508	TSNG-608	35	SNG 508-607
TSNG-509	TSNG-609	40	SNG 509
TSNG-510	TSNG-610	45	SNG 510-608
TSNG-511	TSNG-611	50	SNG 511-609
TSNG-512	TSNG-612	55	SNG 512-610
TSNG-513	TSNG-613	60	SNG 513-611
TSNG-515	TSNG-615	65	SNG 515-612
TSNG-516	TSNG-616	70	SNG 516-613
TSNG-517	TSNG-617	75	SNG 517
TSNG-518		80	SNG 518-615
TSNG-519	TSNG-619	85	SNG 519-616
TSNG-520	TSNG-620	90	SNG 520-617
TSNG-522		100	SNG 522-619
TSNG-524		110	SNG 524-620
TSNG-526		115	SNG 526
TSNG-528		125	SNG 528
TSNG-530		135	SNG 530
TSNG-532		140	SNG 532

组合垫片

ID (d)	OD (D)	H (s)	SES P/N.
3.05	6.35	1.2	BS001
3.6	7.5	1	BS301
4.1	7.2	1	BS201
4.12	7.26	1.2	BS002
4.5	7	1	BS202
4.6	9	1	BS302
5.21	8.38	1.2	BS003
5.6	10	1	BS303
5.7	9	1	BS203
5.7	10	1	BS204
6.2	9.2	1	BS205
6.6	11	1	BS304
6.7	10	1	BS206
6.7	11	1	BS207
6.7	11	2.5	BS208
6.85	13.27	1.3	BS305
6.86	13.21	1.2	BS004
6.99	13.34	1.2	BS005
7	11.4	1	BS306
7.1	12	1	BS209
7.3	10.2	1	BS210
8.3	12.7	1.2	BS519
8.31	13.34	1.2	BS006
8.5	13.4	1	BS211
8.6	13	1	BS307
8.64	14.22	1.2	BS007
8.7	13	1	BS212
8.7	14	1	BS213
8.7	16	1	BS214
9.3	13.3	1	BS215
10.35	16	2	BS216
10.37	15.88	2	BS020
10.4	14.7	1.2	BS510
10.7	16	1.5	BS217

ID (d)	OD (D)	H (s)	SES P/N.
10.7	18	1.5	BS218
10.7	17	1.5	BS310
11.26	18.36	2	BS008
11.4	16.3	1.5	BS219
11.69	19.05	2	BS009
11.8	18.5	1.5	BS220
11.8	19.1	1.5	BS221
11.8	18.1	1.5	BS312
12.7	18	1.5	BS222
12.7	20	1.5	BS223
12.7	19	1.5	BS313
13.7	20	1.5	BS224
13.7	22	1.5	BS225
13.74	20.57	2	BS021
13.8	20.1	1.5	BS315
13.85	18.7	1.2	BS511
14	18.7	1.5	BS226
14.7	22	1.5	BS227
14.7	21	1.5	BS316
14.86	22.23	2	BS010
15.83	22.23	2	BS022
16	22.7	1.5	BS228
16.51	25.4	2	BS011
16.7	24	1.5	BS229
16.7	23	1.5	BS317
17.2	23.9	2	BS319
17.28	23.8	2	BS023
17.35	22.7	1.2	BS512
17.4	24	1.5	BS230
18	24.7	1.5	BS231
18.16	25.4	2.3	BS012
18.7	26	1.5	BS232
18.7	27	2	BS320
19.69	26.92	2.3	BS024

組合墊片Bonded Seal

ID (d)	OD (D)	H (s)	SES P/N.
20.7	28	1.5	BS233
20.7	29	2	BS321
21.5	28.7	2.5	BS234
21.54	28.58	2.5	BS025
21.65	26.7	1.2	BS513
22.5	28	1.5	BS235
22.7	30	2	BS236
22.7	30	3	BS237
22.7	31	2	BS324
23.49	31.75	2.3	BS026
23.7	32	2	BS325
24.26	33.27	2.3	BS013
24.7	32	2	BS238
24.7	33	2	BS326
26.7	35	2	BS239
27	35.3	2	BS327
27.05	34.93	2.3	BS027
27.05	34.93	2.5	BS027
27.2	36	2	BS240
27.3	32.5	1.2	BS514
27.3	32.6	2	BS520
27.7	36	2	BS328
27.82	38.61	2.3	BS028
28.6	36	2	BS329
28.7	37	2	BS241
29.2	37.5	2	BS330
29.33	36.58	2.3	BS014
30.7	39	2	BS331
30.81	38.1	2.3	BS029
31	39	2	BS242
32.64	41.4	3.2	BS015
33.7	42	2	BS243
33.7	42	2	BS332
33.89	42.8	3.2	BS030

ID (d)	OD (D)	H (s)	SES P/N.
33.89	42.8	2.3	BS031
34.2	39.5	2	BS515
34.3	43	2	BS244
35.94	44.45	3.2	BS016
36.7	46	2	BS245
37	48	2.5	BS333
38.96	47.75	3.2	BS017
40	51	2.5	BS246
40	51	2.5	BS334
42.7	53	3	BS247
42.8	49.5	2	BS516
42.93	52.38	3.2	BS032
43	54	2.5	BS335
45.34	57.15	3.2	BS018
46	57	2.5	BS336
48.44	58.6	3.2	BS033
48.7	59	3	BS248
48.7	55.5	2	BS517
49	60	2.5	BS337
51.69	63.5	3.2	BS019
52	60	3	BS249
53.3	64.5	3	BS250
54.89	69.85	3.2	BS034
58.04	70.36	3.2	BS035
60.5	68.5	2	BS518
60.58	73.03	3.2	BS036
60.7	73	3	BS251
64.39	77.22	3.2	BS037
66.68	79.5	3.2	BS038
68.6	79.5	3.5	BS252
76.08	90.17	3.2	BS039
76.08	90.3	3.5	BS253
89.09	101.48	3.2	BS254
127	143.67	5	BS255

组合垫片

ID (d)	OD (D)	H (s)	SES P/N.
3.4	7	1	SCR202
4.5	9	1	SCR203
4.7	10	1	SCR206
4.7	11	1	SCR304
6.3	13	1	SCR307
6.4	13	1	SCR212
6.4	14	1	SCR213
8.05	16.08	1.5	SCR217
8.26	15.88	2	SCR020
9.5	18	1.5	SCR222
9.73	19	1.5	SCR313
10	22	1.5	SCR225
11.18	20.57	2	SCR021
11.38	22	1.5	SCR227
12.9	25.4	2	SCR011
13.41	24	1.5	SCR229
14.5	25.4	2.5	SCR012
14.76	23.8	2	SCR023

ID (d)	OD (D)	H (s)	SES P/N.
3.4	7	1	SCR202
4.5	9	1	SCR203
4.7	10	1	SCR206
4.7	11	1	SCR304
6.3	13	1	SCR307
6.4	13	1	SCR212
6.4	14	1	SCR213
8.05	16.08	1.5	SCR217
8.26	15.88	2	SCR020
9.5	18	1.5	SCR222
9.73	19	1.5	SCR313
10	22	1.5	SCR225
11.18	20.57	2	SCR021
11.38	22	1.5	SCR227
12.9	25.4	2	SCR011
13.41	24	1.5	SCR229
14.5	25.4	2.5	SCR012
14.76	23.8	2	SCR023

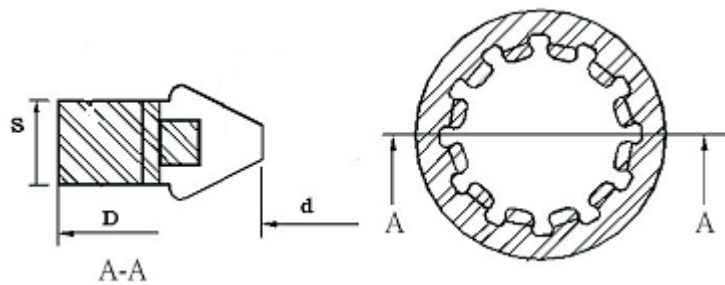

ID (d)	OD (D)	H (s)	SES P/N.
6	15.3	1.2	GMS4059
7.6	15.3	1.3	GMS4057
8.2	16	1.3	GMS4067
9.3	16.8	1.3	GMS4056
10	18.5	1	GMS4058
11.2	19.1	1.3	GMS4068
15.2	33.4	3.1	GMS4065

ID (d)	OD (D)	H (s)	SES P/N.
15.3	28	1.3	GMS4062
15.4	23.6	1.3	GMS4066
15.5	30	3	GMS4060
15.5	30.12	5.53	GMS4063
15.7	30.4	3.66	GMS4064
17.1	25.4	1.3	GMS4069
17.4	31.5	1.3	GSM4061

服務源自專業...

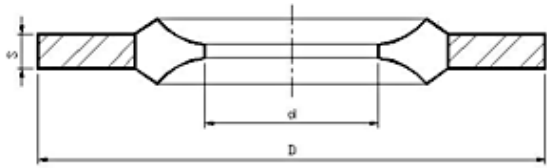

ID(d)	OD(D)	H(s)	SES P/N.	Drawing no.
5.4	14.9	1	BS9007	F087
5.1	14.9	1	BS9008	F087
11.5	22	1.5	BS9004	F087

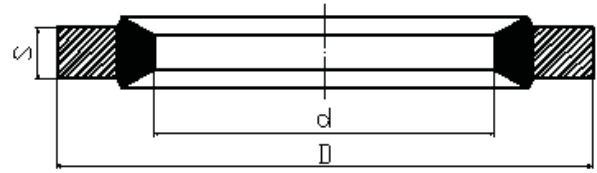

ID (d)	OD (D)	H (s)	SES P/N.
4	8	1	GM 4
5	9	1	GM 5
6	10	1	GM 6
7	11	1	GM 7
8	13	1	GM 7.5
8	14	1	GM 8
10	17	1.5	GM 10
10	18	1.5	GM 11
12	19	1.5	GM 12
14	22	1.5	GM 14
16	24	1.5	GM 16
18	27	1.5	GM 18
18	26.5	2	GM 18
20	30	2	GM 20
22	32	2	GM 22
26	35	2	GM 23
24	36	2	GM 24
27	41	2	GM 27
30	46	2	GM 30
33	50	2.5	GM 33
36	55	2.5	GM 36
39	60	2.5	GM 39
42	65	2.5	GM 42
45	70	3	GM 45
48	75	3	GM 48
52	80	3	GM 52

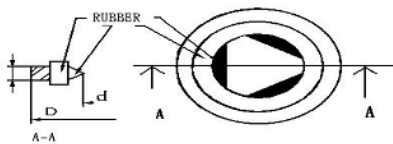

ID (d)	OD (D)	H (s)	SES P/N.
4	9	1	GMA 4

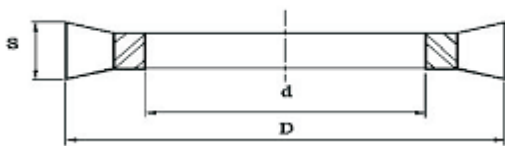

ID (d)	OD (D)	H (s)	SES P/N.
10	16	1.5	UA6005
10.2	16	1.5	UA6004
13.3	21.5	1.5	UA6001
16	22	1.5	UA6007
5.2	8.7	1	UA6006
6.2	1	1	UA6002
8.2	13	1	UA6003

端面密封

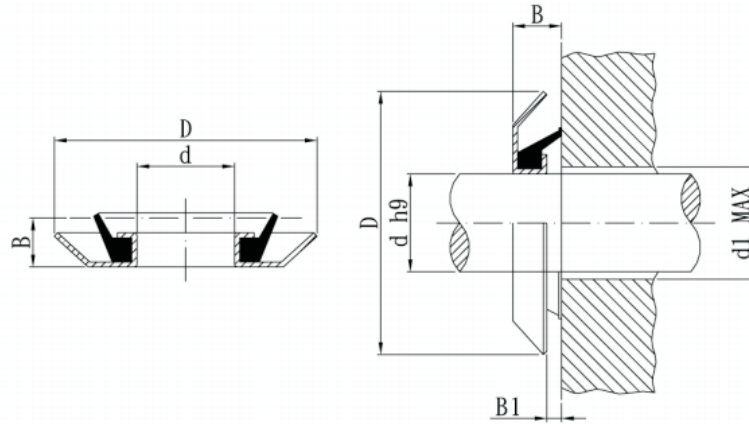

ID	OD	H	Woogor P/N.
10	24	2.5	RE-10
11	26	2.5	RE-11
12	26	2.5	RE-12
14	30	3	RE-14
15	30	3	RE-15
16	32	3	RE-16
17	32	3	RE-17
18	33	3	RE-18
20	35	3	RE-20
22	40	3	RE-22
24	40	3	RE-24
25	40	3	RE-25
26	40	3	RE-26
28	43	3	RE-28
30	47	3.5	RE-30
32	49	3.5	RE-32
35	52	3.5	RE-35
38	55	3.5	RE-38
40	57	3.5	RE-40
41	57	3.5	RE-41
42	59	3.5	RE-42
44.45	31.72	4.826	RE-31
45	62	3.5	RE-45
48	65	3.5	RE-48
50	70	4.5	RE-50
52	72	4.5	RE-52
55	75	4.5	RE-55
58	78	4.5	RE-58
60	80	4.5	RE-60
62	82	4.5	RE-62
65	85	4.5	RE-65
68	88	4.5	RE-68

ID	OD	H	Woogor P/N.
70	90	4.5	RE-70
72	92	4.5	RE-72
75	95	4.5	RE-75
78	98	4.5	RE-78
80	100	4.5	RE-80
85	105	4.5	RE-85
90	110	4.5	RE-90
95	115	4.5	RE-95
100	120	4.5	RE-100
105	125	4.5	RE-105
135	159	5.5	RE-135
225	250	6.5	RE-225
15	32	6	RE1-15
17	34	6	RE1-17
20	37	6	RE1-20
25	42	6	RE1-25
30	48	6.5	RE1-30
35	53	6.5	RE1-35
40	58	6.5	RE1-40
45	63	6.5	RE1-45
50	72	7.5	RE1-50
55	77	7.5	RE1-55
60	82	7.5	RE1-60
65	87	7.5	RE1-65
70	92	7.5	RE1-70
75	97	7.5	RE1-75
80	102	7.5	RE1-80
85	107	7.5	RE1-85
90	112	7.5	RE1-90
95	117	7.5	RE1-95
100	122	7.5	RE1-100

O型环 (O-Ring)

也叫O型圈 (O-Ring)。应其成本低廉，使用方便灵活的特点比广泛地用于各种密封系统。

O型环的密封环境一般分为静密封和动密封。

O型环产品标准较多。一般常用的标准是美国标准 (AS568)、日本标准 (JIS2401)和国际标准 (ISO3601/1)

O型环国际标准一览表

标准	O型环截面直径W (mm)				
美国标准--AS568 英国标准--BS1516	1.78	2.62	3.53	5.33	6.99
日本标准--JIS2401	P系列 1.9 2.4 3.5 5.7 8.4				
	G系列 3.1 5.7				
国际标准--ISO3601/1	1.8	2.65	3.55	5.30	7.00
德国标准--DIN3771/1					
中国标准--GB3452-1					
优先选用的公制尺寸	1.0	1.5	2.0	2.5	3.0
	3.5	4.0	4.5	5.0	5.5
	6.0	7.0	8.0	10.0	12.0
美国标准--AS568 (----900系列)	1.02	1.42	1.63	1.83	1.98
	2.08	2.21	2.46	2.95	3.00

O型环常用材料

材質	代號	主要性能
丁腈橡膠	NBR	耐油、耐磨。使用溫度：-25C----100C
乙丙橡膠	EPDM	耐蒸汽、耐熱水及其他高溫氣體。使用溫度可達到180CH
硅橡膠	SIL,MVQ	耐氧氣、高溫水，僅適用於靜密封。
氟橡膠	VITON,FKM,FPM	耐高溫，耐酸鹼。使用溫度可達250C

O型环

订购O型环时请注意以下几点：

- 1、O型环的常规硬度为：70+/-5A (邵氏硬度)
- 2、高压密封系统请考虑选用90度O型环（140Kg/cm）；
- 3、更高的系统压力时，请考虑使用O型环挡圈（BACK UP Ring），可承受系统压力：600kg/cm
- 4、选型时，线径确定后内径尽可能选小一些；内径确定后，线径尽可能选大一些。

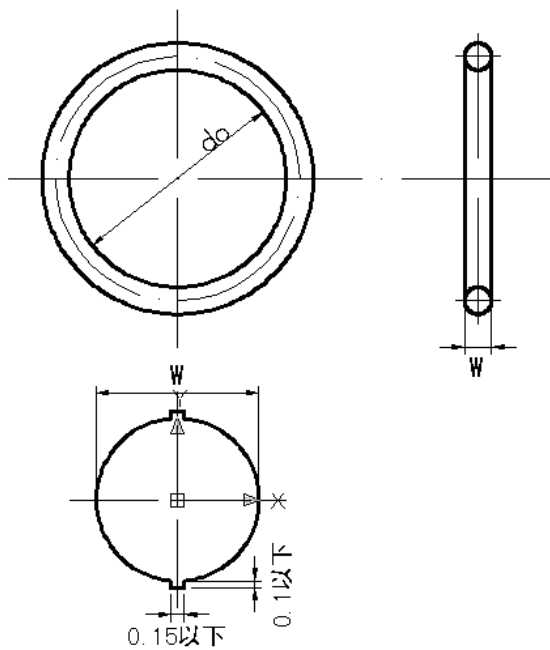

O型圈尺寸

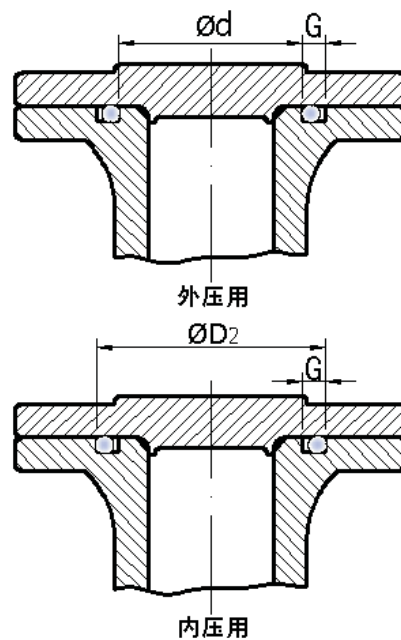

静密封用

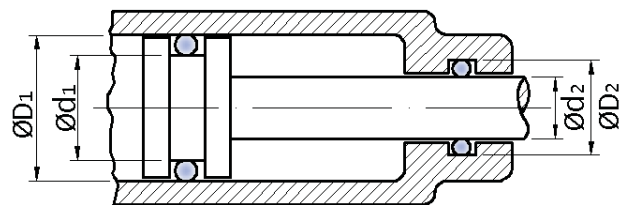
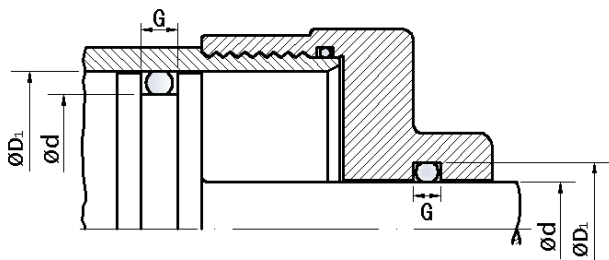

动密封用

JIS2401--P系列

型号	规格
P3	2.80×1.90
P4	3.80×1.90
P5	4.80×1.90
P6	5.80×1.90
P7	6.80×1.90
P8	7.80×1.90
P9	8.80×1.90
P10	9.80×1.90
P10A	9.80×2.40
P11	10.80×2.40
P11.2	11.00×2.40
P12	11.80×2.40
P12.5	12.30×2.40
P014	13.80×2.40
P015	14.80×2.40
P016	15.80×2.40
P018	17.80×2.40
P020	19.80×2.40
P021	20.80×2.40
P022	21.80×2.40
P22A	21.70×3.50
P22.4	22.10×3.50
P24	23.70×3.50
P25	24.70×3.50
P25.5	25.20×3.50
P26	25.70×3.50
P28	27.70×3.50
P29	28.70×3.50
P29.5	29.20×3.50
P30	29.70×3.50
P31	30.70×3.50
P31.5	31.20×3.50
P32	31.70×3.50
P34	33.70×3.50
P35	34.70×3.50
P35.5	35.20×3.50
P36	35.70×3.50
P38	37.70×3.50
P39	38.70×3.50
P40	39.70×3.50
P41	40.70×3.50

型号	规格
P42	41.70×3.50
P44	43.70×3.50
P45	44.70×3.50
P46	45.70×3.50
P48	47.70×3.50
P49	48.70×3.50
P50	49.70×3.50
P48A	47.60×5.70
P50A	49.60×5.70
P52	51.60×5.70
P53	52.60×5.70
P55	54.60×5.70
P56	55.60×5.70
P58	57.60×5.70
P60	59.60×5.70
P62	61.60×5.70
P63	62.60×5.70
P65	64.60×5.70
P67	66.60×5.70
P70	69.60×5.70
P71	70.60×5.70
P75	74.60×5.70
P80	79.60×5.70
P85	84.60×5.70
P90	89.60×5.70
P95	94.60×5.70
P100	99.60×5.70
P102	101.60×5.70
P105	104.60×5.70
P110	109.60×5.70
P112	111.60×5.70
P115	114.60×5.70
P120	119.60×5.70
P125	124.60×5.70
P130	129.60×5.70
P132	131.60×5.70
P135	134.60×5.70
P140	139.60×5.70
P145	144.60×5.70
P150	149.60×5.70

型号	规格
P150A	149.50×8.40
P155	154.50×8.40
P160	159.50×8.40
P165	164.50×8.40
P170	169.50×8.40
P175	174.50×8.40
P180	179.50×8.40
P185	184.50×8.40
P190	189.50×8.40
P195	194.50×8.40
P200	199.50×8.40
P205	204.50×8.40
P209	208.50×8.40
P210	209.50×8.40
P215	214.50×8.40
P220	219.50×8.40
P225	224.50×8.40
P230	229.50×8.40
P235	234.50×8.40
P240	239.50×8.40
P245	244.50×8.40
P250	249.50×8.40
P255	254.50×8.40
P260	259.50×8.40
P265	264.50×8.40
P270	269.50×8.40
P275	274.50×8.40
P280	279.50×8.40
P285	284.50×8.40
P290	289.50×8.40
P295	294.50×8.40
P300	299.50×8.40
P315	314.50×8.40
P320	319.50×8.40
P335	334.50×8.40
P340	339.50×8.40
P355	354.50×8.40
P360	359.50×8.40
P375	374.50×8.40
P385	384.50×8.40
P400	399.50×8.40

服務源自專業...

JIS2401--S系列

规格	内径	线径
S-003	2.5	1.5
S-004	3.5	
S-005	4.5	
S-006	5.5	
S-007	6.5	
S-008	7.5	
S-009	8.5	
S-010	9.5	
S-011.2	10.7	
S-012	11.5	
S-012.5	12.0	
S-014	13.5	
S-015	14.5	
S-016	15.5	
S-018	17.5	
S-020	19.5	
S-022	21.5	
S-022.4	21.9	2.0
S-024	23.5	
S-025	24.5	
S-026	25.5	
S-028	27.5	
S-029	28.5	
S-030	29.5	
S-031.5	31.0	
S-032	31.5	
S-034	33.5	
S-035	34.5	
S-035.5	35.0	
S-036	35.5	
S-038	37.5	
S-039	38.5	
S-040	39.5	

规格	内径	线径
S-042	41.5	2.0
S-044	43.5	
S-045	44.5	
S-046	45.5	
S-048	47.5	
S-050	49.5	
S-053	52.5	
S-055	54.5	
S-056	55.5	
S-060	59.5	
S-063	62.5	
S-065	64.5	
S-067	66.5	
S-070	69.5	
S-071	70.5	
S-075	74.5	
S-080	79.5	
S-085	84.5	
S-090	89.5	
S-095	94.5	
S-100	99.5	
S-105	104.5	
S-110	109.5	
S-112	111.5	
S-115	114.5	
S-120	119.5	
S-125	124.5	
S-130	129.5	
S-132	131.5	
S-135	134.5	
S-140	139.5	
S-145	144.5	
S-150	149.5	

O型环

JIS2401--SS系列

规格	内径	线径
SS-002	1.80	1.0
SS-002.5	2.00	
SS-003	2.50	
SS-003.5	3.00	
SS-004	3.50	
SS-004.5	4.00	
SS-005	4.50	
SS-005.5	5.00	
SS-006	5.50	
SS-006.5	6.00	
SS-007	6.50	
SS-007.5	7.00	
SS-008	7.50	
SS-008.5	8.00	
SS-009	8.50	
SS-009.5	9.00	
SS-010	9.50	
SS-010.5	10.00	
SS-011	10.50	
SS-011.5	11.00	
SS-012	11.50	

JIS2401--V系列

规格	内径	线径
V-15	14.5	4.0
V-24	23.5	
V-34	33.5	
V-40	39.5	
V-55	54.5	
V-70	69.0	
V-85	84.0	
V-100	99.0	
V-120	119.0	
V-150	148.5	
V-175	173.0	6.0
V-225	222.5	
V-275	272.5	
V-325	321.5	
V-380	376.0	
V-430	425.5	10.0
V-480	475.0	
V-530	524.5	
V-585	579.0	
V-640	633.5	
V-690	683.0	
V-740	732.5	
V-790	782.0	
V-845	836.5	
V-950	940.5	
V-1055	1044.0	

服務源自專業...

AS568系列

AS568 NO	配套尺寸		实际尺寸 (英制)			实际尺寸 (公制)	
	内径	外径	宽度	内径+/-公差	线径+/-公差	内径+/-公差	线径+/-公差
-001	1/32	3/32	1/32	0.029±0.004	0.040±0.003	0.74±0.1	1.02±0.08
-002	3/64	9/64	3/64	0.042±0.004	0.050±0.003	1.07±0.1	1.27±0.08
-003	1/16	3/16	1/16	0.056±0.004	0.60±0.003	1.42±0.1	1.52±0.08
-004	5/64	13/64	1/16	0.070±0.005	0.070±0.003	1.78±0.13	1.78±0.08
-005	3/32	7/32	1/16	0.101±0.005	0.070±0.003	2.57±0.13	1.78±0.08
-006	1/8	1/4	1/16	0.114±0.005	0.070±0.003	2.90±0.13	1.78±0.08
-007	5/32	9/32	1/16	0.145±0.005	0.070±0.003	3.68±0.13	1.78±0.08
-008	3/16	5/16	1/16	0.176±0.005	0.070±0.003	4.47±0.13	1.78±0.08
-009	7/32	11/32	1/16	0.208±0.005	0.070±0.003	5.28±0.13	1.78±0.08
-010	1/4	3/8	1/16	0.239±0.005	0.070±0.003	6.07±0.13	1.78±0.08
-011	5/16	7/16	1/16	0.301±0.0005	0.070±0.003	7.65±0.13	1.78±0.08
-012	3/8	1/2	1/16	0.364±0.005	0.070±0.003	9.25±0.13	1.78±0.08
-013	7/16	9/16	1/16	0.426±0.005	0.070±0.003	10.82±0.13	1.78±0.08
-014	1/2	5/8	1/16	0.489±0.005	0.070±0.003	12.42±0.13	1.78±0.08
-015	9/16	11/16	1/16	0.551±0.007	0.070±0.003	14.00±0.18	1.78±0.08
-016	5/8	3/4	1/16	0.614±0.009	0.070±0.003	15.60±0.23	1.78±0.08
-017	11/16	13/16	1/16	0.676±0.009	0.070±0.003	17.17±0.23	1.78±0.08
-018	3/4	7/8	1/16	0.739±0.009	0.070±0.003	18.77±0.23	1.78±0.08
-019	13/16	15/16	1/16	0.801±0.009	0.070±0.003	20.35±0.23	1.78±0.08
-020	7/8	1	1/16	0.864±0.009	0.070±0.003	21.95±0.23	1.78±0.08
-021	15/16	1 1/16	1/16	0.926±0.009	0.070±0.003	23.52±0.23	1.78±0.08
-022	1	1 1/18	1/16	0.989±0.010	0.070±0.003	25.12±0.25	1.78±0.08
-023	1 1/16	1 3/16	1/16	1.051±0.010	0.070±0.003	26.70±0.25	1.78±0.08
-024	1 1/18	1 1/14	1/16	1.114±0.010	0.070±0.003	28.30±0.25	1.78±0.08
-025	1 3/16	1 5/16	1/16	1.176±0.011	0.070±0.003	29.87±0.28	1.78±0.08
-026	1 1/4	1 3/8	1/16	1.239±0.011	0.070±0.003	31.47±0.28	1.78±0.08
-027	1 5/16	1 7/16	1/16	1.301±0.0011	0.070±0.003	33.05±0.28	1.78±0.08
-028	1 3/8	1 1/2	1/16	1.364±0.013	0.070±0.003	34.65±0.33	1.78±0.08
-029	1 1/2	1 5/8	1/16	1.489±0.013	0.070±0.003	37.82±0.33	1.78±0.08
-030	1 5/8	1 3/4	1/16	1.614±0.013	0.070±0.003	41.00±0.33	1.78±0.08
-031	1 3/4	1 7/8	1/16	1.739±0.015	0.070±0.003	44.17±0.38	1.78±0.08
-032	1 7/8	2	1/16	1.864±0.015	0.070±0.003	47.35±0.38	1.78±0.08
-033	2	2 1/8	1/16	1.989±0.018	0.070±0.003	50.52±0.46	1.78±0.08
-034	2 1/8	2 1/4	1/16	2.114±0.018	0.070±0.003	53.7±0.46	1.78±0.08
-035	2 1/4	2 3/8	1/16	2.239±0.018	0.070±0.003	56.87±0.46	1.78±0.08
-036	2 3/8	2 1/2	1/16	2.364±0.018	0.070±0.003	60.05±0.46	1.78±0.08
-037	2 1/2	2 5/8	1/16	2.498±0.018	0.070±0.003	63.22±0.46	1.78±0.08
-038	2 5/8	2 3/4	1/16	2.614±0.020	0.070±0.003	66.40±0.51	1.78±0.08

O型环

AS568 NO	配套尺寸		实际尺寸 (英制)			实际尺寸 (公制)	
	内径	外径	宽度	内径+/-公差	线径+/-公差	内径+/-公差	线径+/-公差
-039	2 3/4	2 7/8	1/16	2.739±0.020	0.070±0.003	69.57±0.51	1.78±0.08
-040	2 7/8	3	1/16	2.864±0.020	0.070±0.003	72.57±0.51	1.78±0.08
-041	3	3 1/8	1/16	2.989±0.024	0.070±0.003	75.92±0.61	1.78±0.08
-042	3 1/4	3 3/8	1/16	3.239±0.024	0.070±0.003	82.27±0.61	1.78±0.08
-043	3 1/2	3 5/8	1/16	3.489±0.024	0.070±0.003	88.62±0.61	1.78±0.08
-044	3 3/4	3 7/8	1/16	3.739±0.027	0.070±0.003	94.97±0.69	1.78±0.08
-045	4	4 1/8	1/16	3.989±0.027	0.070±0.003	101.32±0.69	1.78±0.08
-046	4 1/4	4 3/8	1/16	4.239±0.030	0.070±0.003	107.67±0.76	1.78±0.08
-047	4 1/2	4 5/8	1/16	4.489±0.030	0.070±0.003	114.02±0.76	1.78±0.08
-048	4 3/4	4 7/8	1/16	4.739±0.030	0.070±0.003	120.37±0.76	1.78±0.08
-049	5	5 1/8	1/16	4.989±0.037	0.070±0.003	126.72±0.94	1.78±0.08
-050	5 1/4	5 3/8	1/16	5.239±0.037	0.070±0.003	133.07±0.94	1.78±0.08
-102	1/16	1/4	3/32	0.049±0.005	0.103±0.003	1.24±0.13	2.62±0.08
-103	3/32	9/32	3/32	0.081±0.005	0.103±0.003	2.06±0.13	2.62±0.08
-104	1/8	5/16	3/32	0.112±0.005	0.103±0.003	2.84±0.13	2.62±0.08
-105	5/32	0.34375	3/32	0.143±0.005	0.103±0.003	3.63±0.13	2.62±0.08
-106	3/16	3/8	3/32	0.174±0.005	0.103±0.003	4.42±0.13	2.62±0.08
-107	7/32	13/32	3/32	0.206±0.005	0.103±0.003	5.23±0.13	2.62±0.08
-108	1/4	7/16	3/32	0.237±0.005	0.103±0.003	6.02±0.13	2.62±0.08
-109	5/16	1/2	3/32	0.299±0.005	0.103±0.003	7.59±0.13	2.62±0.08
-110	3/8	9/16	3/32	0.362±0.005	0.103±0.003	9.19±0.13	2.62±0.08
-111	7/16	5/8	3/32	0.424±0.005	0.103±0.003	10.77±0.13	2.62±0.08
-112	1/2	1 1/16	3/32	0.487±0.005	0.103±0.003	12.37±0.13	2.62±0.08
-113	9/16	3/4	3/32	0.549±0.005	0.103±0.003	13.94±0.13	2.62±0.08
-114	5/8	13/16	3/32	0.612±0.009	0.103±0.003	15.54±0.23	2.62±0.08
-115	1 1/16	7/8	3/32	0.674±0.009	0.103±0.003	17.12±0.23	2.62±0.08
-116	3/4	15/16	3/32	0.737±0.009	0.103±0.003	18.72±0.23	2.62±0.08
-117	13/16	1	3/32	0.799±0.010	0.103±0.003	20.29±0.25	2.62±0.08
-118	7/8	1 1/16	3/32	0.862±0.010	0.103±0.003	21.89±0.25	2.62±0.08
-119	15/16	1 1/8	3/32	0.924±0.010	0.103±0.003	23.47±0.25	2.62±0.08
-120	1	1 3/16	3/32	0.987±0.010	0.103±0.003	25.07±0.25	2.62±0.08
-121	1 1/16	1 1/4	3/32	1.049±0.010	0.103±0.003	26.64±0.25	2.62±0.08
-122	1 1/8	1 5/16	3/32	1.112±0.010	0.103±0.003	28.24±0.25	2.62±0.08
-123	1 3/16	1 3/8	3/32	1.174±0.012	0.103±0.003	29.82±0.30	2.62±0.08
-124	1/4	1 7/16	3/32	1.237±0.012	0.103±0.003	31.42±0.30	2.62±0.08
-125	1 5/16	1 1/2	3/32	1.299±0.012	0.103±0.003	32.99±0.30	2.62±0.08
-126	1 3/8	1 9/16	3/32	1.362±0.012	0.103±0.003	34.59±0.30	2.62±0.08
-127	1 7/16	1 5/8	3/32	1.424±0.012	0.103±0.003	36.17±0.30	2.62±0.08
-128	1 1/2	1 2/3	3/32	1.487±0.012	0.103±0.003	37.77±0.30	2.62±0.08
-129	1 9/16	1 3/4	3/32	1.549±0.015	0.103±0.003	39.34±0.38	2.62±0.08
-130	1 5/8	1 13/16	3/32	1.612±0.015	0.103±0.003	40.94±0.38	2.62±0.08
-131	11/16	1 7/8	3/32	1.674±0.015	0.103±0.003	42.52±0.38	2.62±0.08

服務源自專業…

AS568 NO	配套尺寸		实际尺寸 (英制)			实际尺寸 (公制)	
	内径	外径	宽度	内径+/-公差	线径+/-公差	内径+/-公差	线径+/-公差
-132	1 3/4	1 15/16	3/32	1.737±0.015	0.103±0.003	44.12±0.38	2.62±0.08
-133	1 13/16	2	3/32	1.799±0.015	0.103±0.003	45.69±0.38	2.62±0.08
-134	1 7/8	2 1/16	3/32	1.862±0.015	0.103±0.003	47.29±0.38	2.62±0.08
-135	1 15/16	2 1/8	3/32	1.925±0.017	0.103±0.003	48.90±0.43	2.62±0.08
-136	2	2 3/16	3/32	1.987±0.017	0.103±0.003	50.47±0.43	2.62±0.08
-137	2 1/16	2 1/4	3/32	2.050±0.017	0.103±0.003	52.07±0.43	2.62±0.08
-138	2 1/8	2 5/16	3/32	2.112±0.017	0.103±0.003	53.64±0.43	2.62±0.08
-139	2 3/16	2 3/8	3/32	2.175±0.017	0.103±0.003	55.25±0.43	2.62±0.08
-140	2 1/4	2 7/16	3/32	2.237±0.017	0.103±0.003	56.82±0.43	2.62±0.08
-141	2 5/16	2 1/2	3/32	2.300±0.020	0.103±0.003	58.42±0.51	2.62±0.08
-142	2 3/8	2 9/16	3/32	2.362±0.020	0.103±0.003	59.99±0.51	2.62±0.08
-143	2 7/16	2 5/8	3/32	2.425±0.020	0.103±0.003	61.60±0.51	2.62±0.08
-144	2 1/2	2 11/16	3/32	2.487±0.020	0.103±0.003	63.17±0.51	2.62±0.08
-145	2 9/16	2 3/4	3/32	2.550±0.020	0.103±0.003	64.77±0.51	2.62±0.08
-146	2 5/8	2 13/16	3/32	2.612±0.020	0.103±0.003	66.34±0.51	2.62±0.08
-147	2 11/16	2 7/8	3/32	2.675±0.022	0.103±0.003	67.95±0.56	2.62±0.08
-148	2 3/4	2 15/16	3/32	2.737±0.022	0.103±0.003	69.52±0.56	2.62±0.08
-149	2 13/16	3	3/32	2.800±0.022	0.103±0.003	71.12±0.56	2.62±0.08
-150	2 7/8	3 1/16	3/32	2.862±0.022	0.103±0.003	72.69±0.56	2.62±0.08
-151	3	3 3/16	3/32	2.987±0.024	0.103±0.003	75.87±0.61	2.62±0.08
-152	3 1/4	3 7/16	3/32	3.237±0.024	0.103±0.003	82.22±0.61	2.62±0.08
-153	3 1/2	3 11/16	3/32	3.487±0.024	0.103±0.003	88.57±0.61	2.62±0.08
-154	3 3/4	3 15/16	3/32	3.737±0.028	0.103±0.003	94.92±0.71	2.62±0.08
-155	4	4 3/16	3/32	3.987±0.028	0.103±0.003	101.27±0.71	2.62±0.08
-156	4 1/4	4 7/16	3/32	4.237±0.030	0.103±0.003	107.62±0.76	2.62±0.08
-157	4 1/2	4 11/16	3/32	4.487±0.030	0.103±0.003	113.97±0.76	2.62±0.08
-158	4 3/4	4 15/16	3/32	4.737±0.030	0.103±0.003	120.32±0.76	2.62±0.08
-159	5	5 3/16	3/32	4.987±0.035	0.103±0.003	126.67±0.89	2.62±0.08
-160	5 1/4	5 7/16	3/32	5.237±0.035	0.103±0.003	133.02±0.89	2.62±0.08
-161	5 1/2	5 11/16	3/32	5.487±0.035	0.103±0.003	139.37±0.89	2.62±0.08
-162	5 3/4	5 15/16	3/32	5.737±0.035	0.103±0.003	146.48±0.89	2.62±0.08
-163	6	6 3/16	3/32	5.987±0.035	0.103±0.003	152.07±0.89	2.62±0.08
-164	6 1/4	6 7/16	3/32	6.237±0.040	0.103±0.003	158.42±1.02	2.62±0.08
-165	6 1/2	6 11/16	3/32	6.487±0.040	0.103±0.003	164.77±1.02	2.62±0.08
-166	6 3/4	6 15/16	3/32	6.737±0.040	0.103±0.003	171.12±1.02	2.62±0.08
-167	7	7 3/16	3/32	6.987±0.040	0.103±0.003	177.47±1.02	2.62±0.08
-168	7 1/4	7 7/16	3/32	7.237±0.045	0.103±0.003	183.82±1.14	2.62±0.08
-169	7 1/2	7 11/16	3/32	7.487±0.045	0.103±0.003	190.17±1.14	2.62±0.08
-170	7 3/4	7 15/16	3/32	7.737±0.045	0.103±0.003	196.52±1.14	2.62±0.08
-171	8	8 3/16	3/32	7.987±0.045	0.103±0.003	202.87±1.14	2.62±0.08
-172	8 1/4	8 7/16	3/32	8.237±0.050	0.103±0.003	209.22±1.27	2.62±0.08
-173	8 1/2	3 11/16	3/32	8.487±0.050	0.103±0.003	215.57±1.27	2.62±0.08

O型环

AS568 NO	配套尺寸		实际尺寸 (英制)			实际尺寸 (公制)	
	内径	外径	宽度	内径+/-公差	线径+/-公差	内径+/-公差	线径+/-公差
-174	8 3/4	3 15/16	3/32	8.737±0.050	0.103±0.003	221.92±1.27	2.62±0.08
-175	9	9 3/16	3/32	8.987±0.050	0.103±0.003	228.27±1.27	2.62±0.08
-176	9 1/4	9 7/16	3/32	9.237±0.055	0.103±0.003	234.62±1.40	2.62±0.08
-177	9 1/2	9 11/16	3/32	9.487±0.055	0.103±0.003	240.97±1.40	2.62±0.08
-178	9 3/4	9 15/16	3/32	9.737±0.055	0.103±0.003	247.32±1.40	2.62±0.08
-201	3/16	7/16	1/8	0.171±0.005	0.139±0.004	4.34±0.13	3.53±0.10
-202	1/4	1/2	1/8	0.234±0.005	0.139±0.004	5.94±0.13	3.53±0.10
-203	5/16	9/16	1/8	0.296±0.005	0.139±0.004	7.52±0.13	3.53±0.10
-204	3/8	5/8	1/8	0.359±0.005	0.139±0.004	9.12±0.13	3.53±0.10
-205	7/16	11/16	1/8	0.421±0.005	0.139±0.004	10.69±0.13	3.53±0.10
-206	1/2	3/4	1/8	0.484±0.005	0.139±0.004	12.29±0.13	3.53±0.10
-207	9/16	13/16	1/8	0.546±0.007	0.139±0.004	13.87±0.18	3.53±0.10
-208	5/8	7/8	1/8	0.609±0.009	0.139±0.004	15.47±0.23	3.53±0.10
-209	11/16	15/16	1/8	0.671±0.009	0.139±0.004	17.04±0.23	3.53±0.10
-210	3/4	1	1/8	0.734±0.010	0.139±0.004	18.64±0.25	3.53±0.10
-211	13/16	1 1/16	1/8	0.796±0.010	0.139±0.004	20.22±0.25	3.53±0.10
-212	7/8	1 1/8	1/8	0.859±0.010	0.139±0.004	21.82±0.25	3.53±0.10
-213	15/16	1 3/16	1/8	0.921±0.010	0.139±0.004	23.39±0.25	3.53±0.10
-214	1	1 1/4	1/8	0.984±0.010	0.139±0.004	24.99±0.25	3.53±0.10
-215	1 1/16	1 5/16	1/8	1.046±0.010	0.139±0.004	26.57±0.25	3.53±0.10
-216	1 1/8	1 3/8	1/8	1.109±0.012	0.139±0.004	28.17±0.30	3.53±0.10
-217	1 3/16	1 7/16	1/8	1.171±0.012	0.139±0.004	29.74±0.30	3.53±0.10
-218	1 1/4	1 1/2	1/8	1.234±0.012	0.139±0.004	31.34±0.30	3.53±0.10
-219	1 5/16	1 9/16	1/8	1.296±0.012	0.139±0.004	32.92±0.30	3.53±0.10
-220	1 3/8	1 5/8	1/8	1.359±0.012	0.139±0.004	34.52±0.30	3.53±0.10
-221	1 7/16	1 11/16	1/8	1.421±0.012	0.139±0.004	36.09±0.30	3.53±0.10
-222	1 1/2	1 3/4	1/8	1.484±0.015	0.139±0.004	37.69±0.38	3.53±0.10
-223	1 5/8	1 7/8	1/8	1.609±0.015	0.139±0.004	40.87±0.38	3.53±0.10
-224	1 3/4	2	1/8	1.734±0.015	0.139±0.004	44.04±0.38	3.53±0.10
-225	1 7/8	2 1/8	1/8	1.859±0.018	0.139±0.004	47.22±0.46	3.53±0.10
-226	2	2 1/4	1/8	1.984±0.018	0.139±0.004	50.39±0.46	3.53±0.10
-227	2 1/8	2 3/8	1/8	2.109±0.018	0.139±0.004	53.57±0.46	3.53±0.10
-228	2 1/4	2 1/2	1/8	2.234±0.020	0.139±0.004	56.74±0.51	3.53±0.10
-229	2 3/8	2 5/8	1/8	2.359±0.020	0.139±0.004	59.92±0.51	3.53±0.10
-230	2 1/2	2 3/4	1/8	2.484±0.020	0.139±0.004	63.09±0.51	3.53±0.10
-231	2 5/8	2 7/8	1/8	2.609±0.020	0.139±0.004	66.27±0.51	3.53±0.10
-232	2 3/4	3	1/8	2.734±0.024	0.139±0.004	69.44±0.61	3.53±0.10
-233	2 7/8	3 1/8	1/8	2.859±0.024	0.139±0.004	72.62±0.61	3.53±0.10
-234	3	3 1/4	1/8	2.984±0.024	0.139±0.004	75.79±0.61	3.53±0.10
-235	3 1/8	3 3/8	1/8	3.109±0.024	0.139±0.004	78.97±0.61	3.53±0.10
-236	3 1/4	3 1/2	1/8	3.234±0.024	0.139±0.004	82.14±0.61	3.53±0.10
-237	3 3/8	3 5/8	1/8	3.359±0.024	0.139±0.004	85.32±0.61	3.53±0.10

服務源自專業...

AS568 NO	配套尺寸		实际尺寸 (英制)			实际尺寸 (公制)	
	内径	外径	宽度	内径+/-公差	线径+/-公差	内径+/-公差	线径+/-公差
-238	3 1/2	3 3/4	1/8	3.484±0.024	0.139±0.004	88.49±0.61	3.53±0.10
-239	3 5/8	3 7/8	1/8	3.609±0.028	0.139±0.004	91.67±0.71	3.53±0.10
-240	3 3/4	4	1/8	3.734±0.028	0.139±0.004	94.84±0.71	3.53±0.10
-241	3 7/8	4 1/8	1/8	3.859±0.028	0.139±0.004	98.02±0.71	3.53±0.10
-242	4	4 1/4	1/8	3.984±0.028	0.139±0.004	101.19±0.71	3.53±0.10
-243	4 1/8	4 3/8	1/8	4.109±0.028	0.139±0.004	104.37±0.71	3.53±0.10
-244	4 1/4	4 1/2	1/8	4.234±0.030	0.139±0.004	107.54±0.76	3.53±0.10
-245	4 3/8	4 5/8	1/8	4.359±0.030	0.139±0.004	110.72±0.76	3.53±0.10
-246	4 1/2	4 3/4	1/8	4.484±0.030	0.139±0.004	113.89±0.76	3.53±0.10
-247	4 5/8	4 7/8	1/8	4.609±0.030	0.139±0.004	117.07±0.76	3.53±0.10
-248	4 3/4	5	1/8	4.734±0.030	0.139±0.004	120.24±0.76	3.53±0.10
-249	4 7/8	5 1/8	1/8	4.859±0.035	0.139±0.004	123.42±0.89	3.53±0.10
-250	5	5 1/4	1/8	4.984±0.035	0.139±0.004	126.59±0.89	3.53±0.10
-251	5 1/8	5 3/8	1/8	5.109±0.035	0.139±0.004	129.77±0.89	3.53±0.10
-252	5 1/4	5 1/2	1/8	5.234±0.035	0.139±0.004	132.94±0.89	3.53±0.10
-253	5 3/8	5 5/8	1/8	5.359±0.035	0.139±0.004	136.12±0.89	3.53±0.10
-254	5 1/2	5 3/4	1/8	5.484±0.035	0.139±0.004	139.29±0.89	3.53±0.10
-255	5 5/8	5 7/8	1/8	5.609±0.035	0.139±0.004	142.47±0.89	3.53±0.10
-256	5 3/4	6	1/8	5.734±0.035	0.139±0.004	145.64±0.89	3.53±0.10
-257	5 7/8	6 1/8	1/8	5.859±0.035	0.139±0.004	148.82±0.89	3.53±0.10
-258	6	6 1/4	1/8	5.984±0.035	0.139±0.004	151.99±0.89	3.53±0.10
-259	6 1/4	6 1/2	1/8	6.234±0.040	0.139±0.004	158.34±1.02	3.53±0.10
-260	6 1/2	6 3/4	1/8	6.484±0.040	0.139±0.004	164.69±1.02	3.53±0.10
-261	6 3/4	7	1/8	6.734±0.040	0.139±0.004	171.04±1.02	3.53±0.10
-262	7	7 1/4	1/8	6.984±0.040	0.139±0.004	177.39±1.02	3.53±0.10
-263	7 1/4	7 1/2	1/8	7.234±0.045	0.139±0.004	183.74±1.14	3.53±0.10
-264	7 1/2	7 3/4	1/8	7.484±0.045	0.139±0.004	190.09±1.14	3.53±0.10
-265	7 3/4	8	1/8	7.734±0.045	0.139±0.004	196.44±1.14	3.53±0.10
-266	8	8 1/4	1/8	7.984±0.045	0.139±0.004	202.79±1.14	3.53±0.10
-267	8 1/4	8 1/2	1/8	8.234±0.050	0.139±0.004	209.14±1.27	3.53±0.10
-268	8 1/2	8 3/4	1/8	8.484±0.050	0.139±0.004	215.49±1.27	3.53±0.10
-269	8 3/4	9	1/8	8.734±0.050	0.139±0.004	221.84±1.27	3.53±0.10
-270	9	9 1/4	1/8	8.984±0.050	0.139±0.004	228.19±1.27	3.53±0.10
-271	9 1/4	9 1/2	1/8	9.234±0.055	0.139±0.004	234.54±1.40	3.53±0.10
-272	9 1/2	9 3/4	1/8	9.484±0.055	0.139±0.004	240.89±1.40	3.53±0.10
-273	9 3/4	10	1/8	9.734±0.055	0.139±0.004	247.24±1.40	3.53±0.10
-274	10	10 1/4	1/8	9.984±0.055	0.139±0.004	253.59±1.40	3.53±0.10
-275	10 1/2	10 3/4	1/8	10.484±0.055	0.139±0.004	266.29±1.40	3.53±0.10
-276	11	11 1/4	1/8	10.984±0.065	0.139±0.004	278.99±1.65	3.53±0.10
-277	11 1/2	11 3/4	1/8	11.484±0.065	0.139±0.004	291.69±1.65	3.53±0.10
-278	12	12 1/4	1/8	11.984±0.065	0.139±0.004	304.39±1.65	3.53±0.10
-279	13	13 1/4	1/8	12.984±0.065	0.139±0.004	329.79±1.65	3.53±0.10

O型环

AS568 NO	配套尺寸		实际尺寸 (英制)			实际尺寸 (公制)	
	内径	外径	宽度	内径+/-公差	线径+/-公差	内径+/-公差	线径+/-公差
-280	14	14 1/4	1/8	13.984±0.065	0.139±0.004	355.19±1.65	3.53±0.10
-281	15	15 1/4	1/8	14.984±0.065	0.139±0.004	380.59±1.65	3.53±0.10
-282	16	16 1/4	1/8	15.955±0.075	0.139±0.004	405.26±1.91	3.53±0.10
-283	17	17 1/4	1/8	16.955±0.080	0.139±0.004	430.66±2.03	3.53±0.10
-284	18	18 1/4	1/8	17.955±0.085	0.139±0.004	456.06±2.16	3.53±0.10
-309	7/16	13/16	3/16	0.412±0.005	0.210±0.005	10.46±0.13	5.33±0.13
-310	1/2	7/8	3/16	0.475±0.005	0.210±0.005	12.07±0.13	5.33±0.13
-311	9/16	15/16	3/16	0.5370.007	0.2100.005	13.64±0.18	5.33±0.13
-312	5/8	1	3/16	0.600±0.009	0.210±0.005	15.24±0.23	5.33±0.13
-313	11/16	11/16	3/16	0.662±0.009	0.210±0.005	16.81±0.23	5.33±0.13
-314	3/4	1 1/8	3/16	0.725±0.010	0.210±0.005	18.42±0.25	5.33±0.13
-315	13/16	1 3/16	3/16	0.787±0.010	0.210±0.005	19.99±0.25	5.33±0.13
-316	7/8	1 1/4	3/16	0.850±0.010	0.210±0.005	21.59±0.25	5.33±0.13
-317	15/16	1 5/16	3/16	0.912±0.010	0.210±0.005	23.16±0.25	5.33±0.13
-318	1	1 3/8	3/16	0.975±0.010	0.210±0.005	24.77±0.25	5.33±0.13
-319	1 1/16	1 7/16	3/16	1.037±0.010	0.210±0.005	26.34±0.25	5.33±0.13
-320	1 1/8	1 1/2	3/16	1.100±0.012	0.210±0.005	27.94±0.30	5.33±0.13
-321	1 3/16	1 9/16	3/16	1.162±0.012	0.210±0.005	29.51±0.30	5.33±0.13
-322	1 1/4	1 5/8	3/16	1.225±0.012	0.210±0.005	31.12±0.30	5.33±0.13
-323	1 5/16	1 11/16	3/16	1.287±0.012	0.210±0.005	32.69±0.30	5.33±0.13
-324	1 3/8	1 3/4	3/16	1.350±0.012	0.210±0.005	34.29±0.30	5.33±0.13
-325	1 1/2	1 7/8	3/16	1.475±0.015	0.210±0.005	37.47±0.38	5.33±0.13
-326	1 5/8	2	3/16	1.600±0.015	0.210±0.005	40.64±0.38	5.33±0.13
-327	1 3/4	2 1/8	3/16	1.725±0.015	0.210±0.005	43.82±0.38	5.33±0.13
-328	1 7/8	2 1/4	3/16	1.850±0.015	0.210±0.005	46.99±0.38	5.33±0.13
-329	2	2 3/8	3/16	1.975±0.018	0.210±0.005	50.17±0.46	5.33±0.13
-330	2 1/8	2 1/2	3/16	2.100±0.018	0.210±0.005	53.34±0.46	5.33±0.13
-331	2 1/4	2 5/8	3/16	2.225±0.018	0.210±0.005	56.52±0.46	5.33±0.13
-332	2 3/8	2 3/4	3/16	2.350±0.018	0.210±0.005	59.69±0.46	5.33±0.13
-333	2 1/2	2 7/8	3/16	2.4750.020	0.210±0.005	62.87±0.51	5.33±0.13
-334	2 5/8	3	3/16	2.600±0.020	0.210±0.005	66.04±0.51	5.33±0.13
-335	2 3/4	3 1/8	3/16	2.725±0.020	0.210±0.005	69.22±0.51	5.33±0.13
-336	2 7/8	3 1/4	3/16	2.850±0.020	0.210±0.005	72.39±0.51	5.33±0.13
-337	3	3 3/8	3/16	2.975±0.024	0.210±0.005	75.57±0.61	5.33±0.13
-338	3 1/8	3 1/2	3/16	3.100±0.024	0.210±0.005	78.74±0.61	5.33±0.13
-339	3 1/4	3 5/8	3/16	3.225±0.024	0.210±0.005	81.92±0.61	5.33±0.13
-340	3 3/8	3 3/4	3/16	3.350±0.024	0.210±0.005	85.09±0.61	5.33±0.13
-341	3 1/2	3 7/8	3/16	3.475±0.024	0.210±0.005	88.27±0.61	5.33±0.13
-342	3 5/8	4	3/16	3.600±0.028	0.210±0.005	91.44±0.71	5.33±0.13
-343	3 3/4	4 1/8	3/16	3.725±0.028	0.210±0.005	94.62±0.71	5.33±0.13
-344	3 7/8	4 1/4	3/16	3.850±0.028	0.210±0.005	97.79±0.71	5.33±0.13
-345	4	4 3/8	3/16	3.975±0.028	0.210±0.005	100.97±0.71	5.33±0.13

服務源自專業...

AS568 NO	配套尺寸		实际尺寸 (英制)			实际尺寸 (公制)	
	内径	外径	宽度	内径+/-公差	线径+/-公差	内径+/-公差	线径+/-公差
-346	4 1/8	4 1/2	3/16	4.100±0.028	0.210±0.005	104.14±0.71	5.33±0.13
-347	4 1/4	4 5/8	3/16	4.225±0.030	0.210±0.005	107.23±0.76	5.33±0.13
-348	4 3/8	4 3/4	3/16	4.350±0.030	0.210±0.005	110.49±0.76	5.33±0.13
-349	4 1/2	4 7/8	3/16	4.475±0.030	0.210±0.005	113.67±0.76	5.33±0.13
-350	4 5/8	5	3/16	4.600±0.030	0.210±0.005	116.84±0.76	5.33±0.13
-351	4 3/4	5 1/8	3/16	4.725±0.030	0.210±0.005	120.02±0.76	5.33±0.13
-352	4 7/8	5 1/4	3/16	4.860±0.030	0.210±0.005	123.19±0.76	5.33±0.13
-353	5	5 3/8	3/16	4.975±0.037	0.210±0.005	126.37±0.94	5.33±0.13
-354	5 1/8	5 1/2	3/16	5.100±0.037	0.210±0.005	129.54±0.94	5.33±0.13
-355	5 1/4	5 5/8	3/16	5.225±0.037	0.210±0.005	132.72±0.94	5.33±0.13
-356	5 3/8	5 3/4	3/16	5.350±0.037	0.210±0.005	135.89±0.94	5.33±0.13
-357	5 1/2	5 7/8	3/16	5.475±0.037	0.210±0.005	139.07±0.94	5.33±0.13
-358	5 5/8	6	3/16	5.600±0.037	0.210±0.005	142.24±0.94	5.33±0.13
-359	5 3/4	6 1/8	3/16	5.725±0.037	0.210±0.005	145.42±0.94	5.33±0.13
-360	5 7/8	6 1/4	3/16	5.850±0.037	0.210±0.005	148.59±0.94	5.33±0.13
-361	6	6 3/8	3/16	5.975±0.037	0.210±0.005	151.77±0.94	5.33±0.13
-362	6 1/4	6 5/8	3/16	6.225±0.040	0.210±0.005	158.12±1.02	5.33±0.13
-363	6 1/2	6 7/8	3/16	6.475±0.040	0.210±0.005	164.47±1.02	5.33±0.13
-364	6 3/4	7 1/8	3/16	6.725±0.040	0.210±0.005	170.82±1.02	5.33±0.13
-365	7	7 3/8	3/16	6.975±0.040	0.210±0.005	177.17±1.02	5.33±0.13
-366	7 1/4	7 5/8	3/16	7.225±0.045	0.210±0.005	183.52±1.14	5.33±0.13
-367	7 1/2	7 7/8	3/16	7.475±0.045	0.210±0.005	189.87±1.14	5.33±0.13
-368	7 3/4	8 1/8	3/16	7.725±0.045	0.210±0.005	196.22±1.14	5.33±0.13
-369	8	8 3/8	3/16	7.975±0.045	0.210±0.005	202.57±1.14	5.33±0.13
-370	8 1/4	8 5/8	3/16	8.225±0.050	0.210±0.005	208.92±1.27	5.33±0.13
-371	8 1/2	8 7/8	3/16	8.475±0.050	0.210±0.005	215.27±1.27	5.33±0.13
-372	8 3/4	9 1/8	3/16	8.725±0.050	0.210±0.005	221.62±1.27	5.33±0.13
-373	9	9 3/8	3/16	8.975±0.050	0.210±0.005	227.97±1.27	5.33±0.13
-374	9 1/4	9 5/8	3/16	9.225±0.055	0.210±0.005	234.32±1.40	5.33±0.13
-375	9 1/2	9 7/8	3/16	9.475±0.065	0.210±0.005	240.67±1.65	5.33±0.13
-376	9 3/4	10 1/8	3/16	9.725±0.055	0.210±0.005	247.02±1.40	5.33±0.13
-377	10	10 3/8	3/16	9.975±0.055	0.210±0.005	253.37±1.40	5.33±0.13
-378	10 1/2	10 7/8	3/16	10.475±0.060	0.210±0.005	266.07±1.52	5.33±0.13
-379	11	11 3/8	3/16	10.975±0.060	0.210±0.005	278.77±1.52	5.33±0.13
-380	11 1/2	11 7/8	3/16	11.475±0.065	0.210±0.005	291.47±1.65	5.33±0.13
-381	12	12 3/8	3/16	11.975±0.065	0.210±0.005	304.17±1.65	5.33±0.13
-382	13	13 3/8	3/16	12.975±0.065	0.210±0.005	329.57±1.65	5.33±0.13
-383	14	14 3/8	3/16	13.975±0.070	0.210±0.005	354.97±1.78	5.33±0.13
-384	15	15 3/8	1/16	14.975±0.070	0.210±0.005	380.37±1.78	5.33±0.13
-385	16	16 3/8	1/16	15.955±0.075	0.210±0.005	405.26±1.91	5.33±0.13
-386	17	17 3/8	3/16	16.955±0.080	0.210±0.005	430.66±2.03	5.33±0.13
-387	18	18 3/8	3/16	17.955±0.085	0.210±0.005	456.06±2.16	5.33±0.13

O型环

AS568 NO	配套尺寸		实际尺寸 (英制)			实际尺寸 (公制)	
	内径	外径	宽度	内径+/-公差	线径+/-公差	内径+/-公差	线径+/-公差
-388	19	19 3/8	3/16	18.955±0.090	0.210±0.005	481.46±2.29	5.33±0.13
-389	20	20 3/8	3/16	19.995±0.095	0.210±0.005	506.86±2.41	5.33±0.13
-390	21	21 3/8	3/16	20.955±0.095	0.210±0.005	532.26±2.41	5.33±0.13
-391	22	22 3/8	3/16	21.955±0.100	0.210±0.005	557.66±2.54	5.33±0.13
-392	23	23 3/8	3/16	22.940±0.105	0.210±0.006	582.68±2.67	5.33±0.13
-393	24	24 3/8	3/16	23.940±0.110	0.210±0.005	608.08±2.79	5.33±0.13
-394	25	25 3/8	3/16	24.940±0.115	0.210±0.005	633.48±2.92	5.33±0.13
-395	26	26 3/8	3/16	25.940±0.120	0.210±0.005	658.88±3.05	5.33±0.13
400	1 3/8	1 7/8	1/4	1.350±0.012	0.275±0.006	34.29±0.30	6.99±0.15
401	1 1/2	2	1/4	1.475±0.015	0.275±0.006	37.74±0.38	6.99±0.15
402	1 5/8	2 1/8	1/4	1.600±0.015	0.275±0.006	40.64±0.38	6.99±0.15
403	1 3/4	2 1/4	1/4	1.725±0.015	0.275±0.006	43.82±0.38	6.99±0.15
404	1 7/8	2 3/8	1/4	1.850±0.015	0.275±0.006	46.99±0.38	6.99±0.15
405	2	2 1/2	1/4	1.975±0.018	0.275±0.006	50.17±0.46	6.99±0.15
406	2 1/8	2 5/8	1/4	2.100±0.018	0.275±0.006	53.34±0.46	6.99±0.15
407	2 1/4	2 3/4	1/4	2.225±0.018	0.275±0.006	56.52±0.46	6.99±0.15
408	2 3/8	2 7/8	1/4	0.275±0.006	0.275±0.006	59.69±0.46	6.99±0.15
409	2 1/2	3	1/4	2.475±0.020	0.275±0.006	62.87±0.51	6.99±0.15
410	2 5/8	3 1/8	1/4	2.600±0.020	0.275±0.006	66.04±0.51	6.99±0.15
411	2 3/4	3 1/4	1/4	2.725±0.020	0.275±0.006	69.22±0.51	6.99±0.15
412	2 7/8	3 3/8	1/4	2.850±0.020	0.275±0.006	72.39±0.51	6.99±0.15
413	3	3 1/2	1/4	2.975±0.024	0.275±0.006	75.75±0.61	6.99±0.15
414	3 1/8	3 5/8	1/4	3.100±0.024	0.275±0.006	78.74±0.61	6.99±0.15
415	3 1/4	3 3/4	1/4	3.225±0.024	0.275±0.006	81.92±0.61	6.99±0.15
416	3 3/4	3 7/8	1/4	3.350±0.024	0.275±0.006	85.09±0.61	6.99±0.15
417	3 1/2	4	1/4	3.475±0.024	0.275±0.006	88.27±0.61	6.99±0.15
418	3 5/8	4 1/8	1/4	3.600±0.028	0.275±0.006	91.44±0.71	6.99±0.15
419	3 3/4	4 1/4	1/4	3.725±0.028	0.275±0.006	94.62±0.71	6.99±0.15
420	3 7/8	4 3/8	1/4	3.850±0.028	0.275±0.006	97.79±0.71	6.99±0.15
421	4	4 1/2	1/4	3.975±0.028	0.275±0.006	100.97±0.71	6.99±0.15
422	4 1/8	4 5/8	1/4	4.100±0.028	0.275±0.006	104.14±0.71	6.99±0.15
423	4 1/4	4 3/4	1/4	4.225±0.030	0.275±0.006	107.32±0.76	6.99±0.15
424	4 3/8	4 7/8	1/4	4.350±0.030	0.275±0.006	110.49±0.76	6.99±0.15
-425	4 1/2	5	1/4	4.475±0.033	0.275±0.006	113.67±0.84	6.99±0.15
-426	4 5/8	5 1/8	1/4	4.600±0.033	0.275±0.006	116.84±0.84	6.99±0.15
-427	4 3/4	5 1/4	1/4	4.725±0.033	0.275±0.006	120.02±0.84	6.99±0.15
-428	4 7/8	5 3/8	1/4	4.850±0.033	0.275±0.006	123.19±0.84	6.99±0.15
-429	5	5 1/2	1/4	4.975±0.037	0.275±0.006	126.37±0.94	6.99±0.15
-430	5 1/8	5 5/8	1/4	5.100±0.037	0.275±0.006	129.54±0.94	6.99±0.15
-431	5 1/4	5 3/4	1/4	5.225±0.037	0.275±0.006	132.72±0.94	6.99±0.15
-432	5 3/8	5 7/8	1/4	5.350±0.037	0.275±0.006	135.89±0.94	6.99±0.15
-433	5 1/2	6	1/4	5.475±0.037	0.275±0.006	139.07±0.94	6.99±0.15

服務源自專業...

AS568 NO	配套尺寸		实际尺寸 (英制)			实际尺寸 (公制)	
	内径	外径	宽度	内径+/-公差	线径+/-公差	内径+/-公差	线径+/-公差
-434	5 5/8	6 1/8	1/4	5.600±0.037	0.275±0.006	142.24±0.94	6.99±0.15
-435	5 3/4	6 1/4	1/4	5.725±0.037	0.275±0.006	145.42±0.94	6.99±0.15
-436	5 7/8	6 3/8	1/4	5.850±0.037	0.275±0.006	148.59±0.94	6.99±0.15
-437	6	6 1/2	1/4	5.975±0.037	0.275±0.006	151.77±0.94	6.99±0.15
-438	6 1/4	6 3/4	1/4	6.225±0.040	0.275±0.006	158.12±1.02	6.99±0.15
-439	6 1/2	7	1/4	6.475±0.040	0.275±0.006	164.47±1.02	6.99±0.15
-440	6 3/4	7 1/4	1/4	6.725±0.040	0.275±0.006	170.82±1.02	6.99±0.15
-441	7	7 1/2	1/4	6.975±0.040	0.275±0.006	177.17±1.02	6.99±0.15
-442	7 1/4	7 3/4	1/4	7.225±0.045	0.275±0.006	183.52±1.14	6.99±0.15
-443	7 1/2	8	1/4	7.475±0.045	0.275±0.006	189.87±1.14	6.99±0.15
-444	7 3/4	8 1/4	1/4	7.725±0.045	0.275±0.006	196.22±1.14	6.99±0.15
-445	8	8 1/2	1/4	7.975±0.045	0.275±0.006	202.57±1.14	6.99±0.15
-446	8 1/2	9	1/4	8.475±0.055	0.275±0.006	215.27±1.40	6.99±0.15
-447	9	9 1/2	1/4	8.975±0.055	0.275±0.006	227.97±1.40	6.99±0.15
-448	9 1/2	10	1/4	9.475±0.055	0.275±0.006	240.67±1.40	6.99±0.15
-449	10	10 1/2	1/4	9.975±0.055	0.275±0.006	253.37±1.40	6.99±0.15
-450	10 1/2	11	1/4	10.475±0.060	0.275±0.006	266.07±1.52	6.99±0.15
-451	11	11 1/2	1/4	10.975±0.060	0.275±0.006	278.77±1.52	6.99±0.15
-452	11 1/2	12	1/4	11.475±0.060	0.275±0.006	291.47±1.52	6.99±0.15
-453	12	12 1/2	1/4	11.975±0.060	0.275±0.006	304.17±1.52	6.99±0.15
-454	12 1/2	13	1/4	12.475±0.060	0.275±0.006	316.87±1.52	6.99±0.15
-455	13	13 1/2	1/4	12.975±0.060	0.275±0.006	329.57±1.52	6.99±0.15
-456	13 1/2	14	1/4	13.475±0.070	0.275±0.006	342.27±1.78	6.99±0.15
-457	14	14 1/2	1/4	13.975±0.070	0.275±0.006	354.97±1.78	6.99±0.15
-458	14 1/2	15	1/4	14.475±0.070	0.275±0.006	367.67±1.78	6.99±0.15
-459	15	15 1/2	1/4	14.975±0.070	0.275±0.006	380.37±1.78	6.99±0.15
-460	15 1/2	16	1/4	15.475±0.070	0.275±0.006	393.07±1.78	6.99±0.15
-461	16	16 1/2	1/4	15.955±0.075	0.275±0.006	405.26±1.91	6.99±0.15
-462	16 1/2	17	1/4	16.455±0.075	0.275±0.006	417.96±1.91	6.99±0.15
-463	17	17 1/2	1/4	16.955±0.080	0.275±0.006	430.66±2.03	6.99±0.15
-464	17 1/2	18	1/4	17.455±0.085	0.275±0.006	443.36±2.16	6.99±0.15
-465	18	18 1/2	1/4	17.955±0.085	0.275±0.006	456.06±2.16	6.99±0.15
-466	18 1/2	19	1/4	18.455±0.085	0.275±0.006	468.76±2.16	6.99±0.15
-467	19	18 1/2	1/4	18.955±0.090	0.275±0.006	481.46±2.29	6.99±0.15
-468	19 1/2	20	1/4	19.455±0.090	0.275±0.006	494.16±2.29	6.99±0.15
-469	20	20 1/2	1/4	19.955±0.090	0.275±0.006	506.86±2.29	6.99±0.15
-470	21	21 1/2	1/4	20.955±0.090	0.275±0.006	532.26±2.29	6.99±0.15
-471	22	22 1/2	1/4	21.955±0.100	0.275±0.006	557.66±2.54	6.99±0.15
-472	23	23±1/2	1/4	22.940±0.105	0.275±0.006	582.68±2.67	6.99±0.15
-473	24	24 1/2	1/4	23.940±0.110	0.275±0.006	608.08±2.79	6.99±0.15
-474	25	25 1/2	1/4	24.940±0.115	0.275±0.006	633.48±2.92	6.99±0.15
-475	26	16 1/2	1/4	25.940±0.120	0.275±0.006	658.88±3.05	6.99±0.15

O型环

AS568-900系列

Tube Size		O-Ring for Tube Fitting Bosses		ID(mm)	W(mm)
-901	3/32	0.185±0.005	0.056±0.003	4.70±0.13	1.42±0.08
-902	1/8	0.239±0.005	0.064±0.003	6.07±0.13	1.63±0.08
-903	3/16	0.301±0.005	0.064±0.003	7.65±0.13	1.63±0.08
-904	1/4	0.351±0.005	0.072±0.003	8.92±0.13	1.83±0.08
-905	5/16	0.414±0.005	0.072±0.003	10.52±0.13	1.83±0.08
-906	3/8	0.468±0.005	0.078±0.003	11.89±0.13	1.98±0.08
-907	7/16	0.530±0.005	0.082±0.003	13.46±0.13	2.08±0.08
-908	1/2	0.644±0.005	0.087±0.003	16.36±0.13	2.21±0.08
-909	9/16	0.706±0.005	0.097±0.003	17.93±0.13	2.46±0.08
-910	5/8	0.755±0.005	0.097±0.003	19.18±0.13	2.46±0.08
-911	11/16	0.863±0.005	0.116±0.004	21.92±0.13	2.95±0.10
-912	3/4	0.924±0.006	0.116±0.004	23.47±0.15	2.95±0.10
-913	13/16	0.986±0.006	0.116±0.004	25.04±0.15	2.95±0.10
-914	7/8	1.047±0.006	0.116±0.004	26.95±0.15	2.95±0.10
-916	1	1.171±0.006	0.116±0.004	29.74±0.15	2.95±0.10
-918	1 1/8	1.335±0.006	0.116±0.004	34.42±0.15	2.95±0.10
-920	1 1/4	1.475±0.101	0.118±0.004	37.47±0.25	3.00±0.10
-924	1 1/2	1.720±0.010	0.118±0.004	43.69±0.25	3.00±0.10
-928	1 3/4	2.090±0.010	0.118±0.004	53.09±0.25	3.00±0.10
-923	2	2.337±0.010	0.118±0.004	59.36±0.25	3.00±0.10

服務源自專業...

O型圈盒

WOOGOR O-RING KIT-A

30 MOSTPOPULAR SIZES 375PCS

NO	AS568A Dash No	Actual size (millimeters)	Nominal size (inch)			Quantity In Kit	NO	AS568A Dash No	Actual size (millimeters)	Nominal size		Section	Quantity In Kit
			I/D	O/D	Section					I/D	O/D		
001	006	2.90X1.78	1/8	1/4	1/16	20	016	211	20.22X3.53	13/16	1-1/16	1/8	10
002	007	3.68X1.78	5/32	9/32	1/16	20	017	212	21.82X3.53	7/8	1-1/8	1/8	10
003	008	4.47X1.78	3/16	5/16	1/16	20	018	213	23.39X3.53	15/16	1-3/16	1/8	10
004	009	5.28X1.78	7/32	11/32	1/16	20	019	214	24.99X3.53	1	1-1/4	1/8	10
005	010	6.07X1.78	1/4	3/8	1/16	20	020	215	26.57X3.53	1-1/16	1-5/16	1/8	10
006	011	7.65X1.78	5/16	7/16	1/16	20	021	216	28.17X3.53	1-1/8	1-3/8	1/8	10
007	012	9.25X1.78	3/8	1/2	1/16	20	022	217	29.74X3.53	1-3/16	1-7/16	1/8	10
008	110	9.19X2.62	3/8	9/16	3/32	13	023	218	31.34X3.53	1-1/4	1-1/2	1/8	10
009	111	10.77X2.62	7/16	5/8	3/32	13	024	219	32.92X3.53	1-5/16	1-9/16	1/8	10
010	112	12.37X2.62	1/2	11/16	3/32	13	025	220	34.52X3.53	1-3/8	1-5/8	1/8	10
011	113	13.94X2.62	9/16	3/4	3/32	13	026	221	36.09X3.53	1-7/16	1-11/16	1/8	10
012	114	15.54X2.62	5/8	13/16	3/32	13	027	222	37.69X3.53	1-1/2	1-3/4	1/8	10
013	115	17.12X2.62	11/16	7/8	3/32	13	028	325	37.47X5.33	1-1/2	1-7/8	3/16	7
014	116	18.72X2.62	3/4	15/16	3/32	13	029	326	40.64X5.33	1-5/8	2	3/16	7
015	210	18.64X3.53	3/4	1	1/8	10	030	327	43.82X5.33	1-3/4	2-1/8	3/16	7

WOOGOR O-RING KIT-B

30 MOSTPOPULAR SIZES 386PCS

MATERIAL:NBR70

NO	SIZE	ID*W	PCS	NO	SIZE	ID*W	PCS	NO	SIZE	ID*W	PCS
1	P3	2.8*1.9	18	011	P14	13.8*2.4	13	21	G30	29.4*3.1	11
2	P4	3.8*1.9	18	012	P16	15.8*2.4	13	22	P30	29.7*3.5	10
3	P5	4.8*1.9	17	013	P18	17.8*2.4	13	23	P32	31.7*3.5	10
4	P6	5.8*1.9	17	014	P20	19.8*2.4	13	24	P34	33.7*3.5	10
5	P7	6.8*1.9	17	015	P21	20.8*2.4	13	25	G35	34.4*3.1	12
6	P8	7.8*1.9	17	016	P22	21.8*2.4	15	26	P36	35.7*3.5	10
7	P9	8.8*1.9	17	017	P22.4	22.1*3.5	10	27	G40	39.4*3.1	11
8	P10A	9.8*2.4	13	018	G25	24.4*3.1	11	28	P40	39.7*3.5	10
9	P11	10.8*2.4	13	019	P25	24.7*3.5	10	29	G45	44.4*3.1	11
10	P12	11.8*2.4	13	020	P26	25.7*3.5	10	30	P48	47.7*3.5	10

O型圈盒

WOOGOR O-RING KIT-B

30 MOSTPOPULAR SIZES 262PCS

MATERIAL:NBR70

NO	ID*W(Sixe mm)	PCS	NO.	ID*W(Sixe mm)	PCS	NO.	ID*W(Sixe mm)	PCS
001	3*2.0	16	011	14*2.5	13	021	28*3.0	12
002	4*2.0	16	012	16*2.5	13	022	30*3.0	12
003	5*2.0	16	013	17*2.5	13	023	32*3.0	12
004	6*2.0	16	014	19*2.5	13	024	33*3.0	12
005	7*2.0	16	015	19*3.0	12	025	35*3.0	12
006	8*2.0	16	016	20*3.0	12	026	36*3.0	12
007	10*2.0	16	017	22*3.0	12	027	38*3.0	12
008	10*2.5	13	018	24*3.0	12	028	38*4.0	9
009	11*2.5	13	019	25*3.0	12	029	41*4.0	9
010	12*2.5	13	020	27*3.0	12	030	44*4.0	9

O型条O-RING CORD

MATERIAL:VITON 材质：氟橡胶

线径	公差	每卷长度(公尺)
Size(m/m)	Tolerance(±mm)	Packing(M)
1.50	0.12	500
2.00	0.15	500
2.50	0.18	500
3.00	0.18	500
3.50	0.18	400
4.00	0.18	300
4.50	0.18	300
5.00	0.20	200
5.50	0.20	200
6.00	0.20	150
6.50	0.20	150
7.00	0.20	150
7.50	0.20	150
8.00	0.22	150
8.40	0.22	100
8.50	0.22	100
9.00	0.25	80
9.50	0.25	80
10.00	0.28	60

MATERIAL:NBR70 材质：丁腈橡胶(硬度为70)

线径	公差	每卷长度(公尺)
Size(m/m)	Tolerance(±mm)	Packing(M)
1.20	1.20	500
1.50	1.12	500
1.60	0.12	500
1.78	0.15	500
1.90	0.15	500
2.00	0.15	500
2.40	0.18	500
2.50	0.18	500
2.62	0.18	400
3.00	0.18	400
3.17	0.18	400
3.58	0.18	400
4.00	0.18	300
4.50	0.18	300
5.00	0.20	200
5.33	0.20	200
5.50	0.20	200
5.70	0.20	200
6.00	0.20	150
6.35	0.20	150
6.50	0.20	150
7.00	0.20	100
7.50	0.20	100
8.00	0.22	100
8.40	0.22	100
8.50	0.22	100
9.00	0.25	100
9.50	0.25	60
9.53	0.25	60
10.00	0.28	50
11.00	0.28	50
11.11	0.28	50
12.00	0.30	40
12.70	0.30	40
22.00		
25.00		

O型圈挡圈

O型圈背托环系列(BACK UP RING)

名称	尺寸
BRT-P3	3*6*1.25
BRT-P4	4*7*1.25
BRT-P5	5*8*1.25
BRT-P6	6*9*1.25
BRT-P7	7*10*1.25
BRT-P8	8*11*1.25
BRT-P9	9*12*1.25
BRT-P10	10*13*1.25
BRT-P10A	10*14*1.25
BRT-P11	11*14*1.25
BRT-P11.2	11.2*15.2*1.25
BRT-P12	12*16*1.25
BRT-12.5	12.5*16.5*1.25
BRT-P14	14*18*1.25
BRT-P15	15*19*1.25
BRT-P16	16*20*1.25
BRT-P18	18*22*1.25
BRT-P20	20*24*1.25
BRT-P21	21*25*1.25
BRT-P22	22*26*1.25
BRT-P22A	22*28*1.25
BRT-P22.4	22.4*28.4*1.25
BRT-P24	24*30*1.25
BRT-P25	25*31*1.25
BRT-P25.5	25.5*31.5*1.25
BRT-P26	26*32*1.25
BRT-P28	28*34*1.25
BRT-P29	29*35*1.25
BRT-P29.5	29.5*35.5*1.25
BRT-P30	30*36*1.25

名称	尺寸
BRT-P31	31*37*1.25
BRT-P31.5	31.5*37.5*1.25
BRT-P32	32*38*1.25
BRT-P34	34*40*1.25
BRT-P35	35*41*1.25
BRT-P35.5	35.5*41.5*1.25
BRT-P36	36*42*1.25
BRT-P38	38*44*1.25
BRT-P39	39*45*1.25
BRT-P40	40*46*1.25
BRT-P41	41*47*1.25
BRT-P42	42*48*1.25
BRT-P44	44*50*1.25
BRT-P45	45*51*1.25
BRT-P46	46*52*1.25
BRT-P48	48*54*1.25
BRT-P49	49*55*1.25
BRT-P50	50*56*1.25
BRT-P48A	48*58*1.9
BRT-P50A	50*60*1.9
BRT-P52	52*62*1.9
BRT-P53	53*63*1.9
BRT-P55	55*65*1.9
BRT-P56	56*66*1.9
BRT-P58	58*68*1.9
BRT-P60	60*70*1.9
BRT-P62	62*72*1.9
BRT-P63	63*73*1.9
BRT-P65	65*75*1.9
BRT-P67	67*77*1.9

服務源自專業...

名称	尺寸
BRTT-70	70*80*1.9
BRT-P71	71*81*1.9
BRT-P75	75*85*1.9
BRT-P80	80*90*1.9
BRT-P85	85*95*1.9
BRT-P90	90*100*1.9
BRT-P95	95*105*1.9
BRT-P100	100*110*1.9
BRT-P102	102*112*1.9
BRT-P105	105*115*1.9
BRT-P115	115*125*1.9
BRT-P120	120*130*1.9
BRT-P125	125*135*1.9
BRT-P130	130*140*1.9
BRT-P132	132*142*1.9
BRT-P135	135*145*1.9
BRT-P140	140*150*1.9
BRT-P145	145*155*1.9
BRT-P150	150*160*1.9
BRT-P150A	150*165*2.75
BRT-P155	155*170*2.75
BRT-P160	160*175*2.75
BRT-P165	165*180*2.75
BRT-P170	170*185*2.75
BRT-P175	175*190*2.75
BRT-P180	180*195*2.75
BRT-P185	185*200*2.75
BRT-P190	190*205*2.75
BRT-P195	195*210*2.75
BRT-P200	200*215*2.75

名称	尺寸
BRT-P205	205*220*2.75
BRT-P209	209*224*2.75
BRT-P210	210*225*2.75
BRT-P215	215*230*2.75
BRT-P220	220*235*2.75
BRT-P225	225*240*2.75
BRT-P230	230*245*2.75
BRT-P235	235*250*2.75
BRT-P240	240*255*2.75
BRT-P245	245*260*2.75
BRT-P250	250*265*2.75
BRT-P255	255*270*2.75
BRT-P260	260*275*2.75
BRT-P265	265*280*2.75
BRT-P270	270*285*2.75
BRT-P275	275*290*2.75
BRT-P280	280*295*2.75
BRT-P285	285*300*2.75
BRT-P290	290*305*2.75
BRT-P295	295*310*2.75
BRT-P300	300*315*2.75
BRT-P315	315*330*2.75
BRT-P320	320*335*2.75
BRT-P335	335*350*2.75
BRT-P340	340*355*2.75
BRT-P355	355*370*2.75
BRT-P360	360*375*2.75
BRT-P375	375*390*2.75
BRT-P385	385*400*2.75
BRT-P400	400*415*2.75

O型圈挡圈

名称	尺寸
BRT-G25	25*30*1.25
BRT-G30	30*35*1.25
BRT-G35	35*40*1.25
BRT-G40	40*45*1.25
BRT-G45	45*50*1.25
BRT-G50	50*55*1.25
BRT-G55	55*60*1.25
BRT-G60	60*65*1.25
BRT-G65	65*70*1.25
BRT-G70	70*75*1.25
BRT-G75	75*80*1.25
BRT-G80	80*85*1.25
BRT-G85	85*90*1.25
BRT-G90	90*95*1.25
BRT-G95	95*100*1.25
BRT-G100	100*105*1.25
BRT-G105	105*110*1.25
BRT-G110	110*115*1.25
BRT-G115	115-120*1.25
BRT-G120	120*125*1.25
BRT-G125	125*130*1.25
BRT-G130	130*135*1.25
BRT-G135	135*140*1.25
BRT-G140	140*145*1.25
BRT-G145	145*150*1.25

名称	尺寸
BRT-G150	150*160*1.9
BRT-G155	155*165*1.9
BRT-G160	160*170*1.9
BRT-G165	165*175*1.9
BRT-G170	170*180*1.9
BRT-G175	175*185*1.9
BRT-G180	180*190*1.9
BRT-G185	185*195*1.9
BRT-G190	190*200*1.9
BRT-G195	195*205*1.9
BRT-G200	200*210*1.9
BRT-G205	205*215*1.9
BRT-G210	210*220*1.9
BRT-G220	220*230*1.9
BRT-G230	230*240*1.9
BRT-G240	240*250*1.9
BRT-G250	250*260*1.9
BRT-G260	260*270*1.9
BRT-G270	270*280*1.9
BRT-G280	280*290*1.9
BRT-G290	290*300*1.9
BRT-G300	300*310*1.9

星型圈(X-Ring)

X-RING是用4个唇型密封构成的X型断面密封，与O-RING使用相同。如果使用O-RING产生问题时，请使用X-RING，密封效果相当优秀。

公称尺寸：内径（ Φd ）与幅度（ W ）。

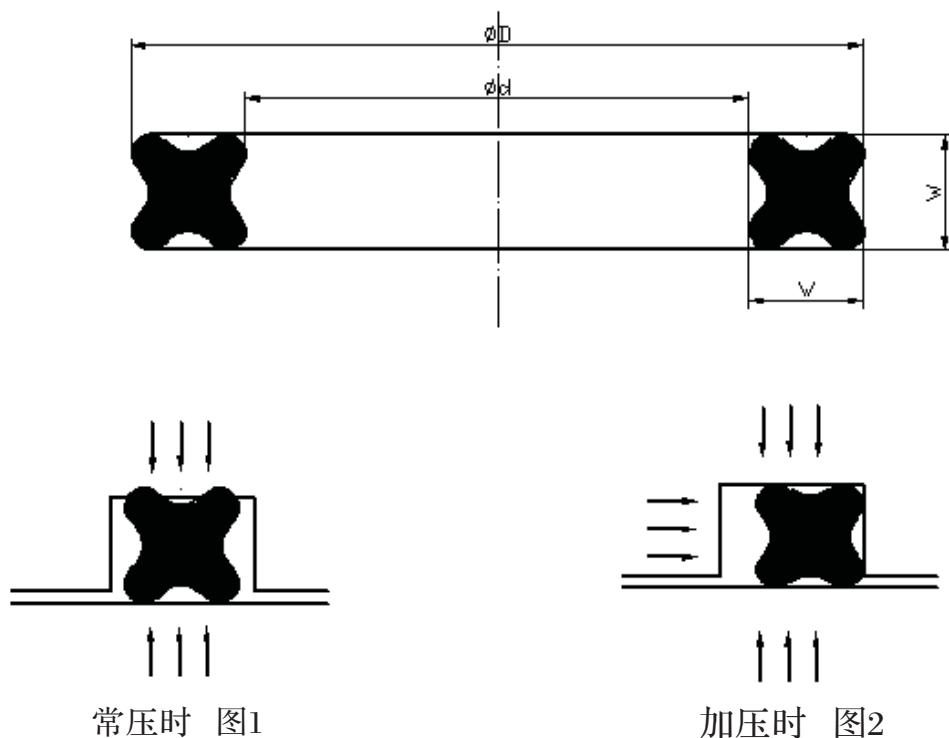

优秀的特征

X-RING比同等规格的O-RING密封效果更优秀。

1、无弯曲现象

O-RING在往复运动时在槽中会产生弯曲（歪）现象，但X-RING由于其特殊的轮廓，不会产生这种弯曲。

2、低磨擦，寿命长

X-RING比相同规格的O-RING受压面小，不仅接触压力，摩擦力及磨损会减小，而且产品耐久性更优秀。X-RING所需的最低受压量可到幅度的5%，因此可以起到更有效的密封效果。

3、密封性优越

X-RING的接触面向全体断面均匀分散，所以比O-RING泄露少。

星型圈

4、成形分模线没有缺陷

普通O-RING内径外径会存在分模线痕，使密封性能降低。但X-RING分模线痕在两个唇之间，不会对密封性能产生影响。

多种材质

NBR、EPDM、CR、FKM、VMQ、HNBR等各种橡胶材料都可以定做。

多种尺寸

遵循US standard AS568有多种尺寸

用途

X-RING可用于运动型及固定型，并且内径及外径兼用。

1、运动用密封

可用于做往复运动油缸的活塞、活塞杆密封；摆动油缸、回转及螺旋运动的轴、定子等。

2、固定用密封

用于轴套、法兰、端盖等半径方向及轴方向密封如图3



图3

工作环境

流体：压缩空气、气体、油、水等

压力：最高压力的40Mpa(PTFE承托环)

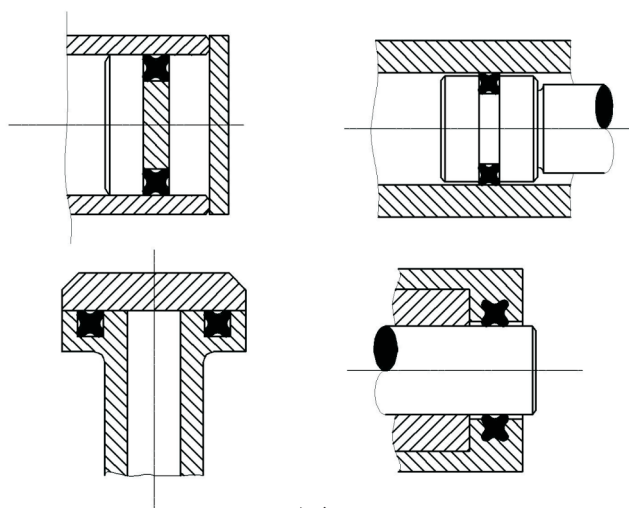
速度：最高约0.5m/s(往复运动)

温度：约-54℃-200℃（根据X-RING的橡胶材质不同而异）

材质：材质根据使用流体及温度而定。硬度根据压力及密封介质而定。

服務源自專業...

尺寸选定

如果内径或活塞杆外径尺寸不同，请根据以下条件选择适当的X-RING尺寸。

1、外径密封时

X-RING的外径与相应的槽内径等同或稍小（2%以内），或者比对应的轴直径约大1%即可。槽内会产生轻微的拥挤，可以防止弯塌。

2、内径密封时

X-RING与对应的活塞杆外径等同或稍小（约0.2-0.3mm），此时的密封系统会使寿命延长。

3、固定用密封及运动用密封

固定用密封断面比较小，用O-RING密封即可。但运动用密封圈需选择较大的断面。采用断面大的X-RING有以下优点：磨损少，允许公差大，压缩变形小，密封性能优越。

沟槽设计

设置在长方形槽内，槽侧面最大允许角度是5度。槽的底部或插入部可以不做角部处理沟槽的宽度请根据尺寸表选定X-RING的密封效果及寿命取决于接触面。使接触面的尽可能减少损伤，因此将接触面积最大化就显得极其重要。

性能参数

技术参数	项目	动密封		静密封	
		往复运动	旋转运动	旋转运动	
工作压力	有档圈		30	15	40
	无档圈		5	——	5
速度 (m/s)		0.5	2.0	——	
温度 (°C)		一般场合：-30°C—+110°C 特殊场合：-60°C—+200°C 旋转场合：-30°C—+80°C			

安装尺寸

截面直径 W	径向初始压缩		沟槽尺寸					半径 r	挤出间距 S _{max}
	动密封 max/min	静密封 max/min	沟槽深度		沟槽宽度				
			动密封 t1+0.05	静密封 t/h+0.05	b1,b4+0.2	b2+0.2	b3+0.2		
1.02	0.300/0.115	0.350/0.165	0.80	0.75	1.20			0.10	0.03
1.27	0.330/0.145	0.430/0.245	1.00	0.90	1.40	—	—	0.10	0.03
1.52	0.350/0.165	0.450/0.265	1.25	1.15	1.70	—	—	0.22	0.04
1.78	0.360/0.175	0.460/0.275	1.50	1.40	2.00	3.40	4.80	0.22	0.05
2.62	0.400/0.215	0.450/0.265	2.30	2.25	3.00	4.40	5.80	0.30	0.08
3.53	0.430/0.205	0.530/0.305	3.20	3.10	4.00	5.40	6.80	0.40	0.08
5.33	0.560/0.250	0.710/0.400	4.90	4.75	6.00	7.70	9.40	0.40	0.10
7.00	0.700/0.350	0.950/0.600	6.40	6.20	8.00	10.50	13.00	0.60	0.10

星型圈

型号	内径		截面尺寸	
	d1	+	w	+
Q001	0.74	0.1	1.02	0.08
Q002	1.07	0.1	1.27	0.08
Q003	1.42	0.1	1.52	0.08
Q003A	1.78	0.13	1.02	0.08
Q004	1.78	0.13	1.78	0.08
Q005A	2	0.13	1.5	0.08
Q005	2.57	0.13	1.78	0.08
Q006	2.9	0.13	1.78	0.08
Q007	3.68	0.13	1.78	0.08
Q008	4.47	0.13	1.78	0.08
Q009	5.28	0.13	1.78	0.08
Q010	6.07	0.13	1.78	0.08
Q011	7.65	0.13	1.78	0.08
Q012A	8.2	0.13	1.78	0.08
Q012A	9.25	0.13	1.78	0.08
Q013	10.82	0.13	1.78	0.08
Q014	12.42	0.13	1.78	0.08
Q015	14	0.13	1.78	0.08
Q016	15.6	0.13	1.78	0.08
Q017	17.17	0.13	1.78	0.08
Q018	18.77	0.13	1.78	0.08
Q019	20.35	0.13	1.78	0.08
Q020	21.95	0.13	1.78	0.08
Q021	23.52	0.13	1.78	0.08
Q022	25.12	0.13	1.78	0.08
Q023	26.7	0.13	1.78	0.08
Q024	28.3	0.13	1.78	0.08
Q025	29.87	0.13	1.78	0.08
Q026	31.47	0.13	1.78	0.08
Q027	33.05	0.13	1.78	0.08
Q028	34.65	0.33	1.78	0.08
Q029	37.82	0.33	1.78	0.08
Q030	41	0.33	1.78	0.08
Q031	44.17	0.38	1.78	0.08
Q032	47.35	0.38	1.78	0.08
Q033	50.52	0.46	1.78	0.08
Q034	53.7	0.46	1.78	0.08

服務源自專業...

型号	内径		截面尺寸	
	d1	+	w	+
Q036	60.05	0.46	1.78	0.08
Q037	63.22	0.46	1.78	0.08
Q038	66.4	0.51	1.78	0.08
Q039	69.57	0.51	1.78	0.08
Q040	72.75	0.51	1.78	0.08
Q041	75.92	0.61	1.78	0.08
Q042	82.27	0.61	1.78	0.08
Q043	88.62	0.61	1.78	0.08
Q044	94.97	0.69	1.78	0.08
Q045	101.32	0.69	1.78	0.08
Q046	107.67	0.76	1.78	0.08
Q047	114.02	0.76	1.78	0.08
Q048	120.37	0.76	1.78	0.08
Q049	126.72	0.94	1.78	0.08
Q050	133.07	0.94	1.78	0.08
Q102	1.24	0.1	2.62	0.08
Q103	2.06	0.13	2.62	0.08
Q104	2.84	0.13	2.62	0.08
Q105	3.63	0.13	2.62	0.08
Q106	4.42	0.13	2.62	0.08
Q107	5.23	0.13	2.62	0.08
Q108	6.02	0.13	2.62	0.08
Q109	7.59	0.13	2.62	0.08
Q110	9.19	0.13	2.62	0.08
Q111A	10.2	0.13	2.62	0.08
Q111	10.77	0.13	2.62	0.08
Q112	12.37	13	2.62	0.08
Q113	13.94	0.18	2.62	0.08
Q114	15.54	0.23	2.62	0.08
Q114A	14.7	0.23	2.62	0.08
Q114B	14.8	0.23	2.62	0.08
Q115A	16.2	0.23	2.62	0.08
Q115	17.12	0.23	2.62	0.08
Q116	18.72	0.23	2.62	0.08
Q117	20.29	0.25	2.62	0.08
Q118	21.89	0.25	2.62	0.08
Q119	23.47	0.25	2.62	0.08

星型圈

型号	内径		截面尺寸	
	d1	+	w	+
Q120	25.07	0.25	2.62	0.08
Q121	26.64	0.25	2.62	0.08
Q122	28.24	0.25	2.62	0.08
Q123	29.82	0.3	2.62	0.08
Q124	31.42	0.3	2.62	0.08
Q125	32.99	0.3	2.62	0.08
Q126	34.59	0.3	2.62	0.08
Q127	36.17	0.3	2.62	0.08
Q128	37.77	0.3	2.62	0.08
Q129	39.34	0.38	2.62	0.08
Q130	40.94	0.38	2.62	0.08
Q131	42.52	0.38	2.62	0.08
Q132	44.12	0.38	2.62	0.08
Q133	45.71	0.38	2.62	0.08
Q134	47.29	0.38	2.62	0.08
Q135	48.9	0.43	2.62	0.08
Q136	50.47	0.43	2.62	0.08
Q137	52.07	0.43	2.62	0.08
Q138	53.64	0.43	2.62	0.08
Q139	55.25	0.43	2.62	0.08
Q140	56.82	0.43	2.62	0.08
Q141	58.42	0.51	2.62	0.08
Q142	59.99	0.51	2.62	0.08
Q143	61.6	0.51	2.62	0.08
Q144	63.17	0.51	2.62	0.08
Q145	64.77	0.51	2.62	0.08
Q146	66.34	0.56	2.62	0.08
Q147	67.95	0.56	2.62	0.08
Q148	69.52	0.56	2.62	0.08
Q149	71.12	0.56	2.62	0.08
Q150	72.69	0.56	2.62	0.08
Q151	75.87	0.61	2.62	0.08
Q152	82.22	0.61	2.62	0.08
Q153	88.57	0.61	2.62	0.08
Q154	94.92	0.71	2.62	0.08
Q155	101.27	0.71	2.62	0.08
Q156	107.62	0.76	2.62	0.08
Q157	113.97	0.76	2.62	0.08
Q158	120.32	0.76	2.62	0.08
Q159	126.67	0.89	2.62	0.08
Q160	133.02	0.89	2.62	0.08

服務源自專業...

型号	内径		截面尺寸	
	d1	+	w	+
Q161	139.37	0.89	2.62	0.08
Q163	152.02	0.89	2.62	0.08
Q164	158.42	1.02	2.62	0.08
Q165	164.77	1.02	2.62	0.08
Q167	177.47	1.02	2.62	0.08
Q168	183.82	1.14	2.62	0.08
Q169	190.17	1.14	2.62	0.08
Q170	196.52	1.14	2.62	0.08
Q171	202.87	1.14	2.62	0.08
Q172	209.22	1.27	2.62	0.08
Q173	215.57	1.27	2.62	0.08
Q174	221.92	1.27	2.62	0.08
Q175	228.27	1.27	2.62	0.08
Q176	234.62	1.4	2.62	0.08
Q177	240.97	1.4	2.62	0.08
Q178	247.32	1.4	2.62	0.08
Q201	4.34	0.13	3.53	0.08
Q202	5.94	0.13	3.53	0.08
Q203	7.52	0.13	3.53	0.08
Q204	9.12	0.13	3.53	0.08
Q205	10.69	0.13	3.53	0.08
Q206	12.29	0.13	3.53	0.08
Q207	13.87	0.18	3.53	0.08
Q208	15.47	0.23	3.53	0.08
Q209	17.04	0.23	3.53	0.08
Q210A	18.2	0.25	3.53	0.08
Q210	18.64	0.25	3.53	0.1
Q211	20.22	0.25	3.53	0.1
Q212	21.81	0.25	3.53	0.1
Q213	23.39	0.25	3.53	0.1
Q214	24.99	0.25	3.53	0.1
Q215	26.57	0.25	3.53	0.1
Q216	28.17	0.25	3.53	0.1
Q217	29.74	0.3	3.53	0.1
Q218	31.34	0.3	3.53	0.1
Q219	32.92	0.3	3.53	0.1
Q220	34.52	0.3	3.53	0.1
Q221	36.09	0.3	3.53	0.1
Q222	37.69	0.38	3.53	0.1
Q223	40.87	0.38	3.53	0.1
Q224	44.04	0.38	3.53	0.1

星型圈

型号	内径		截面尺寸	
	d1	+	w	+
Q225	47.22	0.46	3.53	0.1
Q226	50.39	0.46	3.53	0.1
Q227	53.57	0.46	3.53	0.1
Q228	56.74	0.51	3.53	0.1
Q229	59.92	0.51	3.53	0.1
Q230	63.09	0.51	3.53	0.1
Q231	66.27	0.51	3.53	0.1
Q232	69.44	0.61	3.53	0.1
Q233	72.62	0.61	3.53	0.1
Q234	75.79	0.61	3.53	0.1
Q235	78.97	0.61	3.53	0.1
Q236	82.14	0.61	3.53	0.1
Q237	85.32	0.61	3.53	0.1
Q238	88.49	0.61	3.53	0.1
Q239	91.67	0.71	3.53	0.1
Q240	94.84	0.71	3.53	0.1
Q241	98.02	0.71	3.53	0.1
Q242	101.19	0.71	3.53	0.1
Q243	104.37	0.71	3.53	0.1
Q244	107.54	0.76	3.53	0.1
Q245	110.72	0.76	3.53	0.1
Q246	113.89	0.76	3.53	0.1
Q247	117.07	0.76	3.53	0.1
Q248	120.24	0.76	3.53	0.1
Q249	123.42	0.84	3.53	0.1
Q250	126.59	0.84	3.53	0.1
Q251	129.77	0.84	3.53	0.1
Q252	132.94	0.89	3.53	0.1
Q253	136.12	0.89	3.53	0.1
Q254	139.29	0.89	3.53	0.1
Q255	142.47	0.89	3.53	0.1
Q256	145.64	0.89	3.53	0.1
Q257	148.82	0.89	3.53	0.1
Q258	151.99	0.89	3.53	0.1
Q259	158.34	1.02	3.53	0.1
Q260	164.69	1.02	3.53	0.1
Q261	171.04	1.02	3.53	0.1
Q262	177.39	1.02	3.53	0.1
Q263	183.74	1.14	3.53	0.1
Q264	190.09	1.14	3.53	0.1
Q265	196.44	1.14	3.53	0.1

服務源自專業...

型号	内径		截面尺寸	
	d1	+	w	+
Q266	202.79	1.14	3.53	0.1
Q267	209.14	1.27	3.53	0.1
Q268	215.49	1.27	3.53	0.1
Q269	221.84	1.27	3.53	0.1
Q270	228.19	1.27	3.53	0.1
Q271	234.54	1.4	3.53	0.1
Q272	240.89	1.4	3.53	0.1
Q273	247.24	1.4	3.53	0.1
Q274	253.59	1.4	3.53	0.1
Q275	266.29	1.4	3.53	0.1
Q276	278.99	1.65	3.53	0.1
Q277	291.69	1.65	3.53	0.1
Q278	304.39	1.65	3.53	0.1
Q279	329.79	1.65	3.53	0.1
Q280	355.19	1.65	3.53	0.1
Q281	380.59	1.65	3.53	0.1
Q282	405.26	1.9	3.53	0.1
Q283	430.66	2.16	3.53	0.1
Q284	456.06	2.42	3.53	0.1
Q309	10.46	0.13	5.33	0.13
Q310	12.07	0.13	5.33	0.13
Q311	13.64	0.18	5.33	0.13
Q312	15.24	0.23	5.33	0.13
Q313	16.81	0.23	5.33	0.13
Q314	18.42	0.25	5.33	0.13
Q315	19.99	0.25	5.33	0.13
Q316	21.59	0.25	5.33	0.13
Q317	23.16	0.25	5.33	0.13
Q318	24.77	0.25	5.33	0.13
Q319	26.34	0.25	5.33	0.13
Q320	27.94	0.3	5.33	0.13
Q321	29.51	0.3	5.33	0.13
Q322	31.12	0.3	5.33	0.13
Q323	32.69	0.3	5.33	0.13
Q324	34.29	0.3	5.33	0.13
Q325	37.47	0.38	5.33	0.13
Q326A	39.2	0.38	5.33	0.13
Q326	40.64	0.38	5.33	0.13
Q327	43.82	0.38	5.33	0.13
Q328A	45.2	0.38	5.33	0.13
Q328	46.99	0.38	5.33	0.13

星型圈

型号	内径		截面尺寸	
	d1	+	w	+
Q329	50.17	0.46	5.33	0.13
Q330	53.34	0.46	5.33	0.13
Q331	56.52	0.46	5.33	0.13
Q332	59.69	0.46	5.33	0.13
Q333	62.87	0.51	5.33	0.13
Q334	66.04	0.51	5.33	0.13
Q335	69.22	0.51	5.33	0.13
Q336	72.39	0.51	5.33	0.13
Q337	75.57	0.61	5.33	0.13
Q338	78.74	0.61	5.33	0.13
Q339	81.92	0.61	5.33	0.13
Q340	85.09	0.61	5.33	0.13
Q341	88.27	0.61	5.33	0.13
Q342	91.44	0.71	5.33	0.13
Q343	94.62	0.71	5.33	0.13
Q344	97.79	0.71	5.33	0.13
Q345	100.97	0.71	5.33	0.13
Q346	104.14	0.71	5.33	0.13
Q347	107.32	0.76	5.33	0.13
Q348	110.49	0.76	5.33	0.13
Q349	113.67	0.76	5.33	0.13
Q350	116.84	0.76	5.33	0.13
Q351	120.02	0.76	5.33	0.13
Q352	123.19	0.76	5.33	0.13
Q353	126.37	0.94	5.33	0.13
Q354	129.54	0.94	5.33	0.13
Q355	132.72	0.94	5.33	0.13
Q356	135.89	0.94	5.33	0.13
Q357	139.07	0.94	5.33	0.13
Q358	142.24	0.94	5.33	0.13
Q359	145.42	0.94	5.33	0.13
Q360	148.49	0.94	5.33	0.13
Q361	151.77	0.94	5.33	0.13
Q362	158.12	1.02	5.33	0.13
Q363	164.47	1.02	5.33	0.13
Q364	170.82	1.02	5.33	0.13
Q365	177.17	1.02	5.33	0.13
Q366	185.52	1.14	5.33	0.13
Q367	189.87	1.14	5.33	0.13
Q368	196.22	1.14	5.33	0.13
Q369	202.57	1.14	5.33	0.13

服務源自專業...

型号	内径		截面尺寸	
	d1	+	w	+
Q370	208.92	1.27	5.33	0.13
Q371	215.27	1.27	5.33	0.13
Q372	221.62	1.27	5.33	0.13
Q373	227.97	1.27	5.33	0.13
Q374	234.32	1.4	5.33	0.13
Q375	240.67	1.4	5.33	0.13
Q376	247.02	1.4	5.33	0.13
Q337	75.57	0.61	5.33	0.13
Q378	266.07	1.52	5.33	0.13
Q379	278.77	1.52	5.33	0.13
Q380	291.47	1.65	5.33	0.13
Q381	304.17	1.65	5.33	0.13
Q382	329.57	1.65	5.33	0.13
Q383	354.97	1.78	5.33	0.13
Q384	380.37	1.78	5.33	0.13
Q385	405.26	1.91	5.33	0.13
Q386	430.66	2.03	5.33	0.13
Q387	456.06	2.15	5.33	0.13
Q388	481.41	2.25	5.33	0.13
Q389	506.81	2.41	5.33	0.13
Q390	532.21	2.41	5.33	0.13
Q391	557.61	2.54	5.33	0.13
Q392	582.68	2.67	5.33	0.13
Q393	608.08	2.79	5.33	0.13
Q394	633.48	2.92	5.33	0.13
Q395	658.88	3.05	5.33	0.13
Q425	113.67	0.84	7	0.15
Q426	116.84	0.84	7	0.15
Q427	120.02	0.84	7	0.15
Q428	123.19	0.84	7	0.15
Q429	126.37	0.94	7	0.15
Q430	129.54	0.94	7	0.15
Q431	132.72	0.94	7	0.15
Q432	135.89	0.94	7	0.15
Q433	139.07	0.94	7	0.15
Q434	142.24	0.94	7	0.15
Q435	145.42	0.94	7	0.15
Q436	148.59	0.94	7	0.15
Q437	151.77	0.94	7	0.15
Q438	158.12	1.02	7	0.15
Q439A	160.5	1.02	7	0.15

星型圈

型号	内径		截面尺寸	
	d1	+	w	+
Q439	164.47	1.02	7	0.15
Q440	170.82	1.02	7	0.15
Q441	177.17	1.02	7	0.15
Q442	183.52	1.14	7	0.15
Q443	189.87	1.14	7	0.15
Q444	196.22	1.14	7	0.15
Q445	202.57	1.14	7	0.15
Q446	215.27	1.4	7	0.15
Q448	240.67	1.4	7	0.15
Q449	253.37	1.4	7	0.15
Q450	266.07	1.52	7	0.15
Q451	278.77	1.52	7	0.15
Q452	291.47	1.52	7	0.15
Q453	304.17	1.52	7	0.15
Q454	316.87	1.52	7	0.15
Q455	329.57	1.52	7	0.15
Q456	342.27	1.79	7	0.15
Q457	354.97	1.79	7	0.15
Q458	367.67	1.79	7	0.15
Q459	380.37	1.79	7	0.15
Q460	393.07	1.79	7	0.15
Q461	405.26	1.9	7	0.15
Q462	417.96	1.9	7	0.15
Q463	430.66	2.05	7	0.15
Q464	443.36	2.15	7	0.15
Q465	456.06	2.15	7	0.15
Q466	468.76	2.15	7	0.15
Q467	481.46	2.29	7	0.15
Q468	494.16	2.29	7	0.15
Q469	506.86	2.41	7	0.15
Q470	532.26	2.41	7	0.15
Q471	557.66	2.55	7	0.15
Q472	582.68	2.65	7	0.15
Q473	608.08	2.8	7	0.15
Q474	633.48	2.9	7	0.15
Q475	658.87	3.05	7	0.15

管接头密封垫

Elastomer Seals: DIN 3869

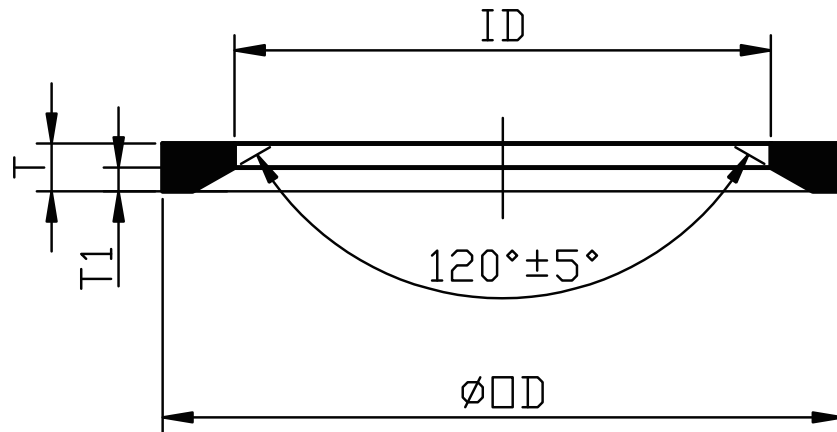

NO.	ID	OD	T	T1	Woogor P/N.
1	6.5	9.9	1.0	0.5	M8
2	8.4	11.9	1.0	0.5	M10 G1/8A
3	9.8	14.4	1.5	0.8	M12
4	11.6	16.5	1.5	0.8	M14 G1/4A
5	13.8	18.9	1.5	0.8	M16
6	14.7	18.9	1.5	0.8	G3/8A
7	15.7	20.9	1.5	0.8	M18
8	17.8	22.9	1.5	0.8	M20
9	18.5	23.9	1.5	0.8	G1/2A
10	19.6	24.3	1.5	0.8	M22
11	23.9	29.2	1.5	0.8	M27 G3/4A
12	29.7	35.7	2.0	1.0	M33 G1A
13	38.8	45.8	2.0	1.0	M42 G1 1/4A
14	44.7	57.7	2.0	1.0	M48 G1 1/2A

活塞组合密封

DAM 型活塞专用组合双作用密封件

1、特点:

滑动材料选用尼龙，适用高压快速工况

2、应用范围

挖掘机、推土机、平路机、装载机、运输车、铲车、冲压机、切割机、折弯机、注塑机、液压设备等

3、使用工况:

往复运动

4、材料:

聚甲醛+聚氨酯+NBR

5、应用极限

最大压力：40 MPa

最大速度：0.5 m/s

温度范围：-40 ~ 100℃

如何决定B的尺寸

决定 $\varnothing B$ 尺寸时，考虑活塞的偏心之后，请把最大挤出间隙（单侧）与下图对照。

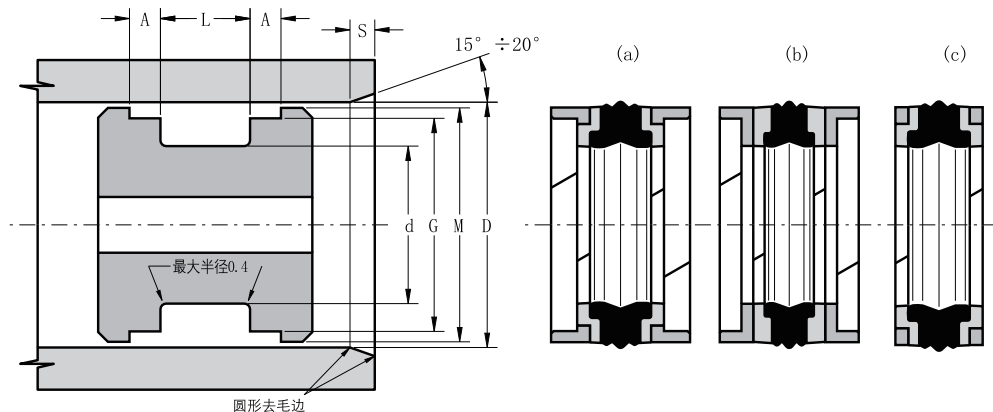

服務源自專業...

序号	型号尺寸	A	B	B1	F	F1	A1
1	DAM 25-15-20	25	15	21.0	12.0	4.00	23.0
2	DAM 25-16-17.7	25	16	22.0	13.5	2.10	24.0
3	DAM 28-19-17.7	28	19	25.0	13.5	2.10	27.0
4	DAM 30-21-17.7	30	21	27.0	13.5	2.10	29.0
5	DAM 32-22-20.7	32	22	28.0	15.5	2.60	31.0
6	DAM 32-22-29.1	32	22	28.5	16.4	6.35	30.5
7	DAM 35-25-20.7	35	25	31.0	15.5	2.60	34.0
8	DAM 35-25-29.1	35	25	31.4	16.4	6.35	33.5
9	DAM 40-24-31.1	40	24	35.4	18.4	6.35	38.5
10	DAM 40-26-20.7	40	26	36.0	15.5	2.60	39.0
11	DAM 40-30-29.1	40	30	35.4	16.4	6.35	38.5
12	DAM 40-30-20.5	40	30	36.0	12.5	4.00	38.0
13	DAM 40-30-20.5	40	30	37.0	12.5	4.00	39.0
14	DAM 42-28-20.7	42	28	38.0	15.5	2.60	41.0
15	DAM 45-29-31.1	45	29	40.4	18.4	6.35	44.0
16	DAM 45-31-20.7	45	31	41.0	15.5	2.60	44.0
17	DAM 45-35-29.1	45	35	40.4	16.4	6.35	43.5
18	DAM 50-34-31.1	50	34	45.4	18.4	6.35	48.5
19	DAM 50-34-26.7	50	34	46.0	20.5	3.10	49.0
20	DAM 50-38-28.9	50	38	46.0	20.5	4.20	48.5
21	DAM 55-39-31.1	55	39	50.36	18.4	6.35	53.5
22	DAM 55-39-26.7	55	39	51.0	20.5	3.10	54.0
23	DAM 56-40-26.7	56	40	52.0	20.5	3.10	55.0
24	DAM 60-44-31.1	60	44	55.4	18.4	6.35	58.5
25	DAM 60-44-26.7	60	44	56.0	20.5	3.10	59.0
26	DAM 60-48-28.9	60	48	56.0	20.5	4.20	58.5
27	DAM 63-47-31.1	63	47	58.4	18.4	6.35	61.5
28	DAM 63-47-32.1	63	47	58.4	19.4	6.35	61.5
29	DAM 63-47-26.7	63	47	59.0	20.5	3.10	62.0
30	DAM 65-51-28.9	65	51	59.0	20.5	4.20	61.5
31	DAM 65-49-26.7	65	49	61.0	20.5	3.10	64.0
32	DAM 65-50-31.1	65	50	60.4	18.4	6.35	63.5
33	DAM 70-50-35.1	70	50	64.2	22.4	6.35	68.3
34	DAM 70-54-26.7	70	54	66.0	20.5	3.10	69.0
35	DAM 70-58-28.9	70	58	66.0	20.5	4.20	68.5
36	DAM 75-55-35.1	75	55	69.2	22.4	6.35	73.3
37	DAM 80-60-35.1	80	60	74.15	22.4	6.35	78.3
38	DAM 80-62-29.7	80	62	76.0	22.5	3.60	79.0
39	DAM 80-66-32.9	80	66	76.0	22.5	5.20	78.5
40	DAM 85-65-35.1	85	65	79.15	22.4	6.35	83.3
41	DAM 90-70-35.1	90	70	84.15	22.4	6.35	88.3
42	DAM 90-72-29.7	90	72	86.0	22.5	3.60	89.0
43	DAM 90-76-32.9	90	76	86.0	22.5	5.20	88.5
44	DAM 95-75-35.1	95	75	89.15	22.4	6.35	93.3
45	DAM 100-75-35.1	100	75	93.15	22.4	6.35	98.0
46	DAM 100-82-29.7	100	82	96.0	22.5	3.60	99.0
47	DAM 100-86-32.9	100	86	96.0	22.5	5.20	98.5

活塞组合密封

序号	型号/尺寸	A	B	B1	F	F1	A1
48	DAM 105-80-35.4	105	80	98.1	22.4	6.5	103.0
49	DAM 110-85-35.1	110	85	103.1	22.4	6.35	108.0
50	DAM 110-92-29.7	110	92	106.0	22.5	3.6	109.0
51	DAM 110-96-32.9	110	96	106.0	22.5	5.2	109.4
52	DAM 115-90-35.1	115	90	108.1	22.4	6.35	113.0
53	DAM 115-97-29.7	115	97	111.0	22.5	3.6	114.0
54	DAM 120-95-35.1	120	95	113.1	22.4	6.35	118.0
55	DAM 120-106-32.9	120	106	116.0	22.5	5.2	118.5
56	DAM 125-100-38.1	125	100	118.1	25.4	6.35	123.0
57	DAM 125-103-36.9	125	103	121.0	26.5	5.2	124.0
58	DAM 125-108-40.9	125	108	121.0	26.5	7.2	124.4
59	DAM 130-105-44.4	130	105	122.6	25.4	9.5	127.5
60	DAM 130-105-38.1	130	105	123.1	25.4	6.35	128.0
61	DAM 135-110-44.4	135	110	127.6	25.4	9.5	132.5
62	DAM 135-110-38.1	135	110	128.1	25.4	6.35	133.0
63	DAM 140-115-44.4	140	115	132.6	25.4	9.5	137.5
64	DAM 140-115-38.1	140	115	133.0	25.4	6.35	138.0
65	DAM 140-118-36.7	140	118	136.0	26.5	5.1	139.0
66	DAM 140-123-40.9	140	123	136.0	26.5	7.2	138.5
67	DAM 145-120-44.4	145	120	137.6	25.4	9.5	142.5
68	DAM 145-120-38.1	145	120	138.3	25.4	6.35	142.95
69	DAM 150-125-44.4	150	125	142.6	25.4	9.5	147.5
70	DAM 150-125-38.1	150	125	143.0	25.4	6.35	148.0
71	DAM 150-128-36.7	150	128	146.0	26.5	5.1	149.0
72	DAM 150-133-40.9	150	133	146.0	26.5	7.2	149.5
73	DAM 155-130-44.4	155	130	147.6	25.4	9.5	152.5
74	DAM 160-135-44.4	160	135	152.6	25.4	9.5	157.5
75	DAM 160-138-36.7	160	138	156.0	26.5	5.1	159.0
76	DAM 160-143-40.9	160	143	156.0	26.5	7.2	159.4
77	DAM 165-140-44.4	165	140	157.6	25.4	9.5	162.5
78	DAM 170-145-50.8	170	145	161.7	25.4	12.7	167.1
79	DAM 175-150-50.8	175	150	166.7	25.4	12.7	172.1
80	DAM 180-150-48.1	180	150	172.95	35.4	6.35	177.87
81	DAM 180-155-50.8	180	155	171.7	25.4	12.7	177.1
82	DAM 185-160-50.8	185	160	176.7	25.4	12.7	182.1
83	DAM 190-165-50.8	190	165	181.7	25.4	12.7	187.0
84	DAM 195-170-50.8	195	170	186.7	25.4	12.7	192.0
85	DAM 200-175-50.8	200	175	191.6	25.4	12.7	197.0
86	DAM 210-185-50.8	210	185	201.6	25.4	12.7	207.0
87	DAM 220-190-48.1	220	190	212.7	35.4	6.35	217.0
88	DAM 220-195-50.8	220	195	211.6	25.4	12.7	217.0
89	DAM 230-205-50.8	230	205	221.6	25.4	12.7	227.0
90	DAM 240-215-50.8	240	215	231.6	25.4	12.7	237.0
91	DAM 250-220-48.1	250	220	242.9	35.4	6.35	247.85
92	DAM 250-225-50.8	250	225	241.6	25.4	12.7	247.0
93	DAM 250-230-49.9	250	230	246.0	31.5	9.20	249.4
94	DAM 280-250-54.44	280	250	272.9	35.4	9.52	277.9
95	DAM 280-250-56.4	280	250	273.0	36.4	10.00	248.0

此表以外的尺寸请向本公司咨询!

服務源自專業...

整体活塞 Complete Piston

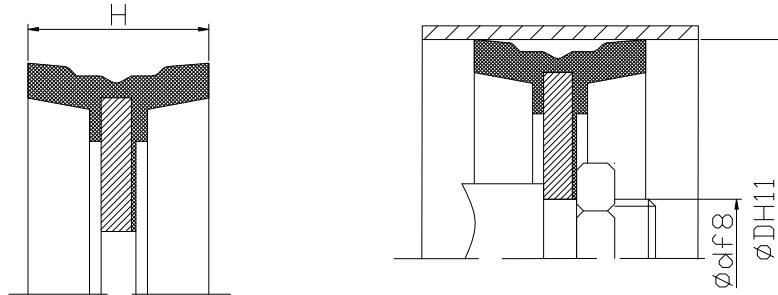

D	d	H	D	d	H
25	8	12	100	16	25
32	8	15	110	18	25
40	10	18	125	20	26
50	10	18	125	20	30
55	10	25	140	20	30
63	12	22	150	20	30
63	16	22	160	27	31
70	12	22	180	27	31
80	16	25	200	27	35
90	16	25	250	30	35

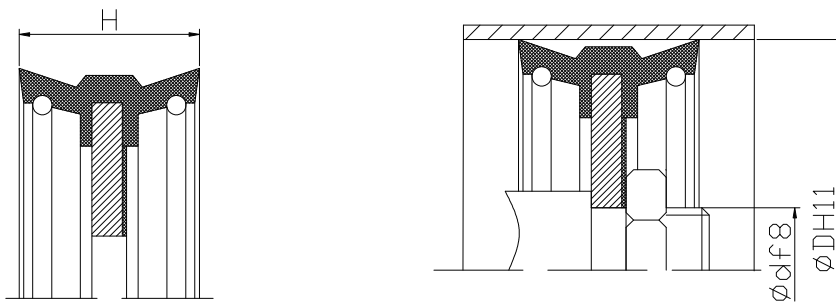

D	d	H	D	d	H
26	8	22	100	12	35
30	8	22	110	12	40
35	8	22	115	20	30
40	10	22	125	20	40
45	10	22	140	20	40
50	10	25	150	20	40
55	10	25	160	20	40
60	12	26	180	20	40
63	12	25	200	20	40
70	12	30	250	30	40
80	12	30	300	35	45

活赛密封

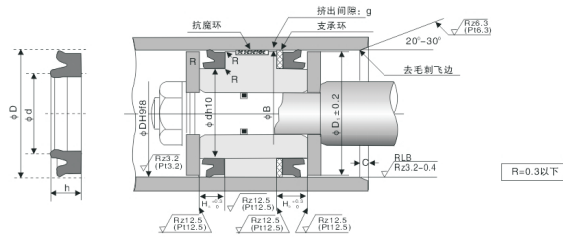

序号	型号	规格	NOK	VALQUA	DZ
1	ODM 16	16*8*5			
2	ODM 18	18*8*7.5	ODI -18		
3	ODM 19.2	19.2*11.2*5	ODI -19.2		D1-11.2
4	ODM 20	20*10*6	ODI-20		
5	ODM 20A	20*10*7.5	ODI-20A		
6	ODM 20B	20*10*8	ODI-20B		
7	ODM 20C	20*12*5	ODI-20C		
8	ODM 22	22*14*5	ODI-22		D1-14
9	ODM 24	24*14*7.5	ODI-24		
10	ODM 25	20*10*6	ODI-25		
11	ODM 25A	20*10*7.5	ODI-25A		
12	ODM 25B	25*10*8	ODI-25B		
13	ODM 25C	25*12*5	ODI-25C		
14	ODM 26	26*16*7.5	ODI-26		
15	ODM 26A	26*18*5	ODI-26A		
16	ODM 28	28*15*10	ODI-28		
17	ODM28A	28*20*5	ODI-28A		
18	ODM 30	30*20*5	ODI-30		
19	ODM 30A	30*20*6	ODI-30A		
20	ODM 30B	30*20*8	ODI-30B		
21	ODM 30C	30*22*5	ODI-30C		
22	ODM 30D	30*22.4*5	ODI-30D		
23	ODM 31	31*18*10	ODI-31		
24	ODM 31.5	31.5*18.5*8	ODI-31.5		
25	ODM 31.5A	31.5*18.5*10	ODI-31.5A		
26	ODM 31.5B	31.5*21.5*6	ODI-31.5B		
27	ODM 31.5C	31.5*21.5*8	ODI-31.5C		
28	ODM 31.5D	31.5*23.5*5	ODI-31.5D		
29	ODM 32	32*22*6			
30	ODM 32A	32*24*5			
31	ODM 33	33*20*10	ODI-33		
32	ODM 33A	33*25*5	ODI-33A		
33	ODM 35	35*22*10	ODI-35		
34	ODM 35A	35*25*6	ODI-35A		
35	ODM 35B	35*25*8	ODI-35B		
36	ODM 35C	35*27*6			
37	ODM 35.4	35.4*22.4*10	ODI-35.4		
38	ODM 35.5	35.5*22.5*8	ODI-35.5		
39	ODM 35.5A	35.5*22.5*10	ODI-35.5A		
40	ODM 35.5B	35.5*25.5*6	ODI-35.5B		
41	ODM 35.5C	35.5*25.5*8	ODI-35.5C		
42	ODM 35.5D	35.5*27.5*5			

服務源自專業...

序号	型号	规格	NOK	VALQUA	DZ
43	ODM 35.5E	35.5*28*5			
44	ODM 35.5F	35.5*28*6			
45	ODM 35.5G	35.5*38*25			
46	ODM 40	40*25*9	ODI-40		
47	ODM 40A	40*25*10	ODI-40A		
48	ODM 40B	40*27*8	ODI-40B		
49	ODM 40C	40*27*10	ODI-40C		
50	ODM 40D	40*30*6	OSI-40	MLP-40	
51	ODM 40E	40*30*8	ODI-40E		
52	ODM 40F	40*32*5			
53	ODM 41	41*28*10	ODI-41		
54	ODM 41.5	41.5*31.5*6	OSI-41.5		
55	ODM 43	43*30*10	ODI-43		
56	ODM 44.5	44.5*31.5*10	ODI-44.5		
57	ODM 45	45*30*6			
58	ODM 45A	45*32*9			
59	ODM 45B	45*32*10	ODI-45B		
60	ODM 45C	45*35*6	OSI-45		
61	ODM 45D	45*35*10			
62	ODM 45E	45*35.5*6	OSI-45		
63	ODM 45F	45*35.5*8	ODI-45A		
64	ODM 50	50*34*10	ODI-50		
65	ODM 50A	50*34*12	ODI-50A		
66	ODM 50B	50*35*9	ODI-50B		
67	ODM 50C	50*35*10	ODI-50C		
68	ODM 50D	50*35*12	ODI-50D		
69	ODM 50E	50*40*6	OSI-50	MLP-50	D1-40
70	ODM 50F	50*40*8	ODI-50F		D1-40
71	ODM 51.5	51.5*35.5*12	ODI-51.5		
72	ODM 55	55*40*9	ODI-55		
73	ODM 55A	55*40*10	ODI-55A		
74	ODM 55B	55*45*6	OSI-55		
75	ODM 55C	55*45*8	ODI-55C		
76	ODM 56	56*40*10	ODI-56		
77	ODM 56A	56*40*12	ODI-56A		
78	ODM 56B	56*41*9	ODI-56B		
79	ODM 56C	56*41*10	ODI-56C		
80	ODM 56D	56*45*7	OSI-56		
81	ODM 56E	56*46*6	OSI-56A		
82	ODM 56F	56*46*8	ODI-56F		
83	ODM 60	60*45*9	ODI-60		
84	ODM 60A	60*45*10	ODI-60A		

活赛密封

序号	型号	规格	NOK	VALQUA	DZ
85	ODM 60B	60*50*6	OSI-60		
86	ODM 60C	60*50*8	ODI-60C		
87	ODM 61	61*45*12	ODI-61		
88	ODM 63	63*47*10	ODI-63		
89	ODM 63A	63*47*12	ODI-63A		
90	ODM 63B	63*48*9	ODI-63B		
91	ODM 63C	63*48*10	ODI-63C		
92	ODM 63D	63*53*6	OSI-63	MLP-63	
93	ODM 63E	63*53*8	ODI-63E		
94	ODM 65	65*50*9	ODI-65		
95	ODM 65A	65*50*10	ODI-65A		
96	ODM 65B	65*55*6	OSI-65		
97	ODM 65C	65*55*8	ODI-65C		
98	ODM 66	66*50*12	ODI-66		
99	ODM 66A	66*56*6	OSI-66		
100	ODM 69	69*53*12	ODI-69		
101	ODM 70	70*50*12	ODI-70		D1-50
102	ODM 70A	70*55*9	ODI-70A		D1-55
103	ODM 70B	70*55*10	ODI-70B		D1-55
104	ODM70C	70*60*6	OSI-70		DI-60
105	ODM 70D	70*60*8	ODI-70D		D1-60
106	ODM 71	71*51*12	ODI-71		
107	ODM 71A	71*55*10	ODI-71A		
108	ODM 71B	71*55*12	ODI-71B		
109	ODM 71C	71*56*9	ODI-71C		
110	ODM 71D	71*56*10	ODI-71D		
111	ODM 71E	71*60*7	OSI-71		
112	ODM 71F	71*61*6	OSI-71A		
113	ODM 71G	71*61*8	ODI-71G		
114	ODM 73	73*63*6	OSI-73		
115	ODM 75	75*55*12	ODI-75		
116	ODM 75A	75*60*12	ODI-75A		
117	OSM 75B	75*60*10	ODI-75B		
118	ODM 75C	75*65*6	OSI-75		
119	ODM 75D	75*65*8	ODI-75D		
120	ODM 76	76*60*12	ODI-76		
121	ODM 77	77*67*6	OSI-77		
122	ODM 80	80*60*12	ODI-80		
123	ODM 80A	80*64*10	ODI-80A		
124	ODM 80B	80*64*12	ODI-80B		D1-64
125	ODM 80C	80*65*9	ODI-80C		
126	ODM 80D	80*65*10	ODI-80D		D1-65

服務源自專業…

序号	型号	规格	NOK	VALQUA	DZ
127	ODM 80E	80*70*6	OSI-80		D1-70
128	ODM 80F	80*70*8	ODI-80		D1-70A
129	ODM 80G	80*71*6	OSI-80A	MLP-80	
130	ODM 85	85*65*12	ODI-85		
131	ODM 85A	85*70*9	ODI-85A		
132	ODM 85B	85*70*10	ODI-85B		
133	ODM 85C	85*75*6	OSI-85		
134	ODM 85D	85*75*8	ODI85C		
135	ODM 90	90*70*12	ODI-90		
136	ODM 90A	90*70*15	ODI-90A		
137	ODM 90B	90*75*9	ODI-90B		D1-75
138	ODM 90C	90*75*10	ODI-90C		D1-75A
139	ODM 90D	90*80*6	OSI-90		D1-80
140	ODM 90E	90*80*8	ODI-90D		
141	ODM 95	95*75*12	ODI-95		
142	ODM 95A	95*75*15	ODI-95A		
143	ODM 95B	95*80*9	ODI-95B		
144	ODM 95C	95*80*10	ODI-95C		
145	ODM 100	100*80*12	ODI-100		
146	ODM 100A	100*80*15	ODI-100A		
147	ODM 100B	100*85*9	OSI-100	MLP-100	D1-85
148	ODM 100C	100*85*10	ODI-100B		
149	ODM 105	105*85*15	ODI-105		
150	ODM 105A	105*90*9	OSI-105		
151	ODM 110	110*90*12	ODI-110		
152	ODM 110A	110*90*15	ODI-110A		
153	ODM 110B	110*95*9	OSI-110		D1-95
154	ODM 110C	110*95*10	ODI-110B		
155	ODM 112	112*92*12	ODI-112		
156	ODM 112A	112*92*15	ODI-112A		
157	ODM 112B	112*97*9	ODI-112B		
158	ODM 112C	112*97*10	ODI-112C		
159	ODM 112D	112*98*8.5	OSI-112		
160	ODM 115	115*95*15	ODI-115		
161	ODM 115A	115*110*9			
162	ODM 115B	115*100*15			
163	ODM 115C	115*105*9	OSI-115		
164	ODM 115D	115*105*10			
165	ODM 115E	115*106*8.5			
166	ODM 125	125*100*15			
167	ODM 125A	125*105*12	ODI-125		
168	ODM 125B	125*105*15	ODI-125A		
169	ODM 125C	125*105*16	ODI-125B	MLP-125	

活赛密封

序号	型号	规格	NOK	VALQUA	DZ
170	ODM 125D	125*110*9	ODI-125C		D1-110
171	ODM125E	125*110*10	ODI-125D		D1-110A
172	ODM 125F	125*112*9	OSI-125	UHP-125	D1-112
173	ODM 130	130*110*12	ODI-130		D1-110B
174	ODM 130A	130*110*15	ODI-130A		
175	ODM 130B	130*110*16	ODI-130B		
176	ODM 130C	130*115*9	OSI-130		D1-115
177	ODM 130D	130*115*10	ODI-130C		
178	ODM 132	132*112*15	ODI-132		
179	ODM 135	135*115*12			
180	ODM 140	140*120*12	ODI-140		
181	ODM 140A	140*120*15	ODI-140A		
182	ODM 140B	140*120*16	ODI-140B	MLP-140	
183	ODM 140C	140*125*9	OSI-140		D1-125
184	ODM 140D	140*125*10	ODI-140C		
185	ODM 145	145*125*12			
186	ODM 150	150*125*19	ODI-150		
187	ODM 150A	150*125*20	ODI-150A		
188	ODM 150B	150*130*12	ODI-150B		
189	ODM 150C	150*130*16	ODI-130C		
190	ODM 150D	150*135*9	OSI-150		D1-135
191	ODM 150E	150*135*10	ODI-150D		
192	ODM 150F	150*136*8.5	OSI-150A		
193	ODM 155	155*135*12			
194	ODM 155A	155*140*9	OSI-155		
195	ODM 157	157*132*20	ODI-175		
196	ODM 160	160*135*15		MLP-160	
197	ODM 160A	160*135*19	ODI-160		
198	ODM 160B	160*135*20	ODI-160A		
199	ODM 160C	160*140*12	ODI-160B		
200	ODM 160D	160*140*16	ODI-160C		
201	ODM 160E	160*145*9	OSI-160		D1-145
202	ODM 160F	160*145*10	ODI-160D		
203	ODM 165	165*140*19	ODI-165		
204	ODM 165A	165*140*20	ODI-165A		
205	ODM 170	170*145*19	ODI-170		
206	ODM 170A	170*145*20	ODI-170A		
207	ODM 170B	170*150*12	ODI-170B		
208	ODM 170C	170*150*16	ODI-170C		
209	ODM 170D	170*155*9	OSI-170		D1-155
210	ODM 170E	170*155*10	ODI-170D		
211	ODM 175	175*160*9	OSI-175		
212	ODM 180	180*155*16	ODI-180	UNP-180	
213	ODM 180A	180*155*19	ODI-180A		
214	ODM 180B	180*155*20	ODI-180B		
215	ODM 180C	180*160*12	ODI-180C		

服務源自專業...

序号	型号	规格	NOK	VALQUA	DZ
216	ODM 180D	180*160*16	ODI-180D		
217	ODM 180E	180*165*9	OSI-180		D1-165
218	ODM 180F	180*165*10	ODI-180E		
219	ODM 185	185*160*19	ODI-185		
220	ODM 185A	185*160*20	ODI-185A		
221	ODM 190	190*165*16	ODI-190	UNP-190	
222	ODM 190A	190*165*20	ODI-190A		
223	ODM 190B	190*170*12	ODI-190B		
224	ODM 190C	190*170*16	ODI-190C		
225	ODM 190D	190*175*9	OSI-190		D1-175
226	ODM 190E	190*175*10	ODI-190D		
227	ODM 200	200*170*19			
228	ODM 200A	200*175*15			
229	ODM 200B	200*175*16	ODI-200	UNP-200	
230	ODM 200C	200*175*19	ODI-200A		
231	ODM 200D	200*175*20	ODI-200B		
232	ODM 200E	200*180*12	OSI-200		
233	ODM 200F	200*180*16	ODI-200C		
234	ODM 205	205*180*19	ODI-205		
235	ODM 205A	205*180*20	ODI-205A		
236	ODM 210	210*185*16	ODI-210		
237	ODM 210A	210*185*20	ODI-210A		
238	ODM 210B	210*190*12	OSI-210		D1-190
239	ODM 210C	210*190*16	ODI-210B		
240	ODM 220	220*195*15			
241	ODM 220A	220*195*16	ODI-220		
242	ODM 220B	220*195*20	ODI-220A		
243	ODM 220C	220*200*12	OSI-220		D1-200
244	ODM 220D	220*200*16	ODI-220B		
245	ODM 224	224*199*16	ODI-224	UNP-224	
246	ODM 224A	224*199*20	ODI-224A		
247	ODM 224B	224*204*12	OSI-224		
248	ODM 224C	224*204*16	ODI-224B		
249	ODM 225	225*200*16	ODI-225		
250	ODM 225A	225*200*19	ODI-225A		
251	ODM 225B	225*200*20	ODI-225B		
252	ODM 225C	225*205*12	OSI-225		
253	ODM 225D	225*205*16	ODI-225C		
254	ODM 230	230*205*16	ODI-230		
255	ODM 230A	230*205*19	ODI-230A		
256	ODM 230B	230*205*20	ODI-230B		
257	ODM 230C	230*210*12	OSI-230		
258	ODM 230D	230*210*16	ODI-230C		
259	ODM 240	240*215*16	ODI-240		D1-210
260	ODM 240A	240*215*19	ODI-240A		
261	ODM 240B	240*215*20	ODI-240B		

活赛密封

序号	型号	规格	NOK	VALQUA	DZ
262	ODM 240C	240*220*12	OSI-240		
263	ODM 240D	240*220*16	ODI-240C		
264	ODM 250	250*220*19			
265	ODM 250A	250*225*15			
266	ODM 250B	250*225*16	ODI-250		
267	ODM 250C	250*225*19	ODI-250A	UNP-250	D1-225
268	ODM 250D	250*225*20	ODI-250B		
269	ODM 250E	250*230*12	OSI-250		
270	ODM 250F	250*230*16	ODI-250C		
271	ODM 260	260*235*16	ODI-260		
272	ODM 260A	260*235*19	ODI-260A		
273	ODM 260B	260*240*12	OSI-260		
274	ODM 260C	260*240*16	ODI-260B		
275	ODM 270	270*245*16	ODI-270		
276	ODM 270A	270*245*19	ODI-270A		
277	ODM 270B	270*250*12	OSI-270		
278	ODM 270C	270*250*16	ODI-270B		
279	ODM 275	275*250*19	ODI-275	UNP275	
280	ODM 275A	275*250*20	ODI-275A		
281	ODM 280	280*250*19	ODI-280		
282	ODM 280A	280*255*15			
283	ODM 280B	280*255*16	OSI-280		
284	ODM 280C	280*255*19	ODI-280A	UNP-280	
285	ODM 285	285*255*19			
286	ODM 290	290*260*19	ODI-290		
287	ODM 290A	290*265*16	ODI-290A		
288	ODM 290B	290*265*19	OSI-290		
289	ODM 297	297*265*24	ODI-297		
290	ODM 297A	297*265*25	ODI-297A		
291	ODM 300	300*270*19	ODI-300		D1-270
292	ODM 300A	300*270*24	ODI-300A		
293	ODM 300B	300*270*25	ODI-300B		
294	ODM 300C	300*275*16	OSI-300		
295	ODM 300D	300*275*19	ODI-300C		
296	ODM 312	312*280*24	ODI-312		
297	ODM 320	320*290*19			D1-290
298	ODM 320A	320*295*15			
299	ODM 332	332*300*24	ODI-332		

服務源自專業...

活塞杆密封IDM

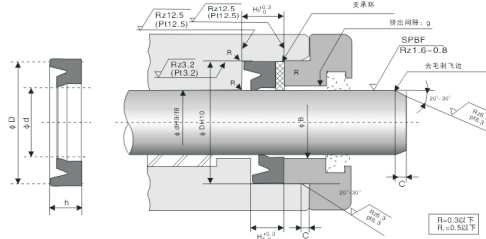

序号	型号	规格	NOK	VALQUA	DZ
1	IDM 4	4*12*5			
2	IDM 5	5*13*5			
3	IDM 6	6*14*5			
4	IDM 6.3	6.3*14.3*5	IDI-6.3		
5	IDM 6.3A	6.3*16.3*6	IDI-6.3A		
6	IDM 6.3B	6.3*16.3*7.5	IDI-6.3B		
7	IDM 6.3C	6.3*16.3*8	IDI-6.3C		
8	IDM 8	8*16*5	IDI-8		
9	IDM 8A	8*18*6	IDI-8A		
10	IDM 8B	8*18*7.5	IDI-8B		
11	IDM 8C	8*18*8	IDI-8C		
12	IDM 9	9*17*5	IDI-9		
13	IDM 9A	9*19*6	IDI-9A		
14	IDM 9B	9*19*7.5	IDI-9B		
15	IDM 9C	9*19*8	IDI-9C		
16	IDM 10	10*18*5	IDI-10		
17	IDM 10A	10*20*6	IDI-10A		
18	IDM 10B	10*20*7.5	IDI-10B		
19	IDM 10C	10*20*8	IDI-10C		
20	IDM 11.2	11.2*19.2*5	IDI-11.2		
21	IDM 11.2A	11.2*21.2*6	IDI-11.2A		
22	IDM 11.2B	11.2*21.2*7.5	IDI-11.2B		
23	IDM 11.2C	11.2*21.2*8	IDI-11.2C		
24	IDM 12	12*20*5			
25	IDM 12A	12*22*6			
26	IDM 12.5	12.5*20.5*5	IDI-12.5		
27	IDM 12.5A	12.5*22.5*6	IDI-12.5A		
28	IDM 12.5B	12.5*22.5*7.5	IDI-12.5B		
29	IDM 12.5C	12.5*22.5*8	IDI-12.5C		
30	IDM 14	14*22*5	IDI-14		D2-14
31	IDM 14A	14*24*6	IDI-14A		
32	IDM 14B	14*24*7.5	IDI-14B		
33	IDM 14C	14*24*8	IDI-14C		
34	IDM 15	15*23*5	IDI-15		
35	IDM 15A	15*25*6	IDI-15A		
36	IDM 15B	15*25*8	IDI-15B		
37	IDM 15C	15*28*8	IDI-15C		
38	IDM 15D	15*28*10	IDI-15D		
39	IDM 16	16*24*5	IDI-16		
40	IDM 16A	16*26*6	IDI-16A		
41	IDM 16B	16*26*7.5	IDI-16B		
42	IDM 16C	16*26*8	IDI-16C		
43	IDM 18	18*26*5	ISI-18	UHR-18	
44	IDM 18A	18*28*6	IDI-18		
45	IDM 18B	18*28*8	IDI-18A		
46	IDM 18C	18*31*8	IDI-18B		

活赛杆密封

序号	型号	规格	NOK	VALQUA	DZ
47	IDM 18D	18*31*10	IDI-18C		
48	IDM 20	20*28*5	ISI-20	UHR-20	
49	IDM 20A	20*30*6	IDI-20		
50	IDM 20B	20*30*8	IDI-20A		
51	IDM 20C	20*33*8	IDI-20B		
52	IDM 20D	20*33*10	IDI-20C		D2-20
53	IDM 20E	20*36*9			
54	IDM 22	22*30*5			
55	IDM 22A	22*32*6			
56	IDM 22B	22*35*10	IDI-22		
57	IDM 22.4	22.4*30*5	ISI-22.4	UHR-22.4	D2-22.4
58	IDM 22.4A	22.4*30.4*5	ISI-22.4A		
59	IDM 22.4B	22.4*32.4*6	IDI-22.4		
60	IDM 22.4C	22.4*32.4*8	IDI-22.4A		
61	IDM 22.4D	22.4*35.4*8	IDI-22.4B		
62	IDM 22.4E	22.4*35.4*10	IDI-22.4C	MLR-22.4	
63	IDM 23.5	23.5*31.5*5	ISI-23.5		
64	IDM 25	25*33*5	ISI-25		D2-25A1
65	IDM 25A	25*35*5	ISI-25A		
66	IDM 25B	25*35*6	IDI-25		
67	IDM 25C	25*35*8	IDI-25A		
68	IDM 25D	25*38*8	IDI-25B		
69	IDM 25E	25*38*10	IDI-25C		
70	IDM 25F	25*40*9	IDI-25D		
71	IDM 25G	25*40*10	IDI-25E		
72	IDM 27	27*40*10	IDI-27		
73	IDM 28	28*35.5*5	ISI-28	UHR-28	D2-28
74	IDM 28A	28*36*5	ISI-28A		
75	IDM 28B	28*38*6	IDI-28		
76	IDM 28C	28*38*8	IDI-28A		
77	IDM 28D	28*41*8	IDI-28B		
78	IDM 28E	28*41*10	IDI-28C	MLR-28	
79	IDM 28F	28*43*9	IDI-28D		
80	IDM 28G	28*43*10	IDI-28E		
81	IDM 30	30*40*6	ISI-30		D2-30
82	IDM 30A	30*40*8	IDI-30		
83	IDM 30B	30*43*10	IDI-30A		D2-30A1
84	IDM 30C	30*45*9	IDI-30B		
85	IDM 30D	30*45*10	IDI-30C		
86	IDM 30E	30*46*9			
87	IDM31.5	31.5*41.5*6	ISI-31.5		
88	IDM 31.5A	31.5*41.5*8	IDI-31.5		
89	IDM 31.5B	31.5*44.5*8	IDI-31.5A		
90	IDM 31.5C	31.5*44.5*10	IDI-31.5B		
91	IDM 31.5D	31.5*46.5*9	IDI-31.5C		
92	IDM 31.5E	31.5*46.5*10	IDI-31.5D		

服務源自專業…

序号	型号	规格	NOK	VALQUA	DZ
93	IDM 32	32*40*5			D2-32A1
94	IDM 32A	32*42*6			D2-32A2
95	IDM 32B	32*47*9			
96	IDM 34	34*50*12	IDI-34		
97	IDM 35	35*45*6	ISI-35		D2-35A1
98	IDM 35A	35*45*8	IDI-35		
99	IDM 35B	35*50*9	IDI-35A		
100	IDM 35C	35*50*10	IDI-35B		
101	IDM 35D	35*50*12	IDI-35C		
102	IDM 35E	35*51*9			
103	IDM 35.5	35.5*45*6	ISI-35.5	UHR-35.5	
104	IDM 35.5A	35.5*45.5*6	ISI-35.5A		
105	IDM 35.5B	35.5*45.5*8	IDI-35.5		
106	IDM 35.5C	35.5*50.5*9	IDI-35.5A		
107	IDM 35.5D	35.5*50.5*10	IDI-35.5B		
108	IDM 35.5E	35.5*51.5*10	IDI-35.5C	MLR-35.5	
109	IDM 35.5F	35.5*51.5*12	IDI-35.5D		
110	IDM 35.5G	35.5*53.5*10			
111	IDM 36	36*46*6			
112	IDM 36A	36*51*9			
113	IDM 40	40*50*6	ISI-40	UHR-40	D2-40
114	IDM 40A	40*50*8	IDI-40		
115	IDM 40B	40*55*9	IDI-40A		D2-40B
116	IDM 40C	40*55*10	IDI-40B		D2-40C
117	IDM 40D	40*56*10	IDI-40C		
118	IDM 40E	40*56*12	IDI-40E		
119	IDM 40F	40*60*12			
120	IDM 45	45*55*6	ISI-45	UHR-45A	D2-45A1
121	IDM 45A	45*55*8	IDI-45		
122	IDM 45B	45*56*7	ISI-45A	UHR-45	
123	IDM 45C	45*56*12			
124	IDM 45D	45*60*9	IDI-45A		D2-45B
125	IDM 45E	45*60*10	IDI-45B		
126	IDM 45F	45*61*10	IDI-45C	MLR-45	
127	IDM 45G	45*61*12	IDI-45D		
128	IDM 45H	45*65*12			
129	IDM 47	47*63*12	IDI-47		
130	IDM 50	50*60*6	ISI-50	UHR-50	D2-50
131	IDM 50A	50*60*8	IDI-50		
132	IDM 50B	50*65*9	IDI-50A		D2-50B
133	IDM 50C	50*65*10	IDI-50B		
134	IDM 50D	50*66*10	IDI-50C		
135	IDM 50E	50*66*12	IDI-50D		
136	IDM 50F	50*70*12	IDI-50E		
137	IDM 52	52*67*9			
138	IDM 53	53*63*6	ISI-53		

活赛杆密封

序号	型号	规格	NOK	VALQUA	DZ
139	IDM 53A	53*69*12	IDI-53		
140	IDM 55	55*65*6	ISI-55		D2-55
141	IDM 55A	55*65*8	IDI-55		
142	IDM 55B	55*70*9	IDI-55A		D2-55B
143	IDM 55C	55*70*10	IDI-55B		
144	IDM 55D	55*71*10	IDI-55C		
145	IDM 55E	55*71*12	IDI-55D		
146	IDM 55F	55*75*12	IDI-55E		
147	IDM 56	56*66*6	ISI-56	UHR-56	
148	IDM 56A	56*66*8	IDI-56		
149	IDM 56B	56*71*9	IDI-56A		
150	IDM 56C	56*71*10	IDI-56B		
151	IDM 56D	56*72*10	IDI-56C	MLR-56	
152	IDM 56E	56*72*12	IDI-56D		
153	IDM 56F	56*76*12	IDI-56E		
154	IDM 60	60*70*6	ISI-60		D2-60A1-2
155	IDM 60A	60*70*8	IDI-60		
156	IDM 60B	60*71*7	ISI-60A		
157	IDM 60C	60*75*9	IDI-60A		D2-60A
158	IDM 60D	60*75*10	IDI-60B		
159	IDM 60E	60*76*10	IDI-60C		
160	IDM 60F	60*76*12	IDI-60D		
161	IDM 60G	60*80*12	IDI-60E		D2-60B
162	IDM 63	63*73*6	ISI-63	UHR-63	
163	IDM 63A	63*73*8	IDI-63		
164	IDM 63B	63*78*9	IDI-63A		
165	IDM 63C	63*78*10	IDI-63B		
166	IDM 63D	63*79*10	IDI-63C		
167	IDM 63E	63*79*12	IDI-63D		
168	IDM 63F	63*83*12	IDI-63E		
169	IDM 64	64*80*12	IDI-64		
170	IDM 65	65*75*6	ISI-65		D2-65
171	IDM 65A	65*75*8	IDI-65		
172	IDM 65B	65*80*9	IDI-65A		D2-65B
173	IDM 65C	65*80*12	IDI-65B		D2-65C
174	IDM 65D	65*85*12	IDI-65C		D2-65D
175	IDM 67	67*77*6	ISI-67	UHR-67	
176	IDM 67A	67*82*9	IDI-67		
177	IDM 67B	67*87*15	IDI-67A		
178	IDM 70	70*80*6	ISI-70		D2-40A1
179	IDM 70A	70*80*8	IDI-70		
180	IDM 70B	70*85*9	IDI-70A		D2-70B
181	IDM 70C	70*85*10	IDI-70B		
182	IDM 70D	70*90*12	IDI-70C		D2-70C
183	IDM 70E	70*90*15	IDI-70D		
184	IDM 71	71*81*6	ISI-71	UHR-71	

服務源自專業...

序号	型号	规格	NOK	VALQUA	DZ
185	IDM 71A	71*81*8	IDI-71		
186	IDM 71B	71*86*9	IDI-71A		
187	IDM 71C	71*86*10	IDI-71B		
188	IDM 71D	71*91*12	IDI-71C		
189	IDM 71E	71*91*15	IDI-71D	MLR-71	
190	IDM 75	75*85*6	ISI-75		D2-75
191	IDM 75A	75*85*8	IDI-75		
192	IDM 75B	75*90*9	IDI-75A		D2-75B
193	IDM 75C	75*90*10	IDI-75B		
194	IDM 75D	75*95*12	IDI-75C		D2-75C
195	IDM 75E	75*95*15	IDI-75D		
196	IDM 80	80*90*6	ISI-80	UHR-80	
197	IDM 80A	80*90*8	IDI-80		D2-80
198	IDM 80B	80*95*9	IDI-80A		D2-80C
199	IDM 80C	80*95*10	IDI-80B		
200	IDM 80D	80*100*12	IDI-80C		D2-80D
201	IDM 80E	80*100*15	IDI-80D	MLR-80	
202	IDM 85	85*100*9	ISI-85	UHR-85	D2-85
203	IDM 85A	85*100*10	IDI-85		D2-85A
204	IDM 85B	85*105*12	IDI-85A		D2-85B
205	IDM 85C	85*105*15	IDI-85B		
206	IDM 90	90*105*9	ISI-90	UHR-90	
207	IDM 90A	90*105*10	IDI-90		D2-90A
208	IDM 90B	90*110*12	IDI-90A		D2-90C
209	IDM 90C	90*110*15	IDI-90B	MLR-90	
210	IDM 90D	90*115*15	IDI-90C		
211	IDM 95	95*110*9	ISI-95		D2-95
212	IDM 95A	95*110*10	IDI-95		D2-95A
213	IDM 95B	95*115*12	IDI-95A		D2-95C
214	IDM 95C	95*115*15	IDI-95B		
215	IDM 98	98*112*8.5	ISI-98		
216	IDM 100	100*115*9	ISI-100	UHR-100	D2-100
217	IDM 100A	100*115*10	IDI-100		D2-100A
218	IDM 100B	100*120*12	IDI-100A		D2-100C
219	IDM 100C	100*120*15	IDI-100B	MLR-100	
220	IDM 105	105*120*9	ISI-105		D2-105
221	IDM 105A	105*120*10	IDI-105		
222	IDM 105B	105*125*12			D2-105A
223	IDM 105C	105*125*15	IDI-105A		
224	IDM 105D	105*125*16	IDI-105B		
225	IDM 106	106*120*8.5	ISI-106		
226	IDM 106A	106*121*9	ISI-106A		
227	IDM 106B	106*121*10	IDI-106		
228	IDM 106C	106*126*15	IDI-106A		
229	IDM 106D	106*126*16	IDI-106B		
230	IDM 110	110*125*9	ISI-110		D2-110

活赛杆密封

序号	型号	规格	NOK	VALQUA	DZ
231	IDM 110A	110*125*10	IDI-110		
232	IDM 110B	110*130*12			D2-110A
233	IDM 110C	110*130*15	IDI-110A		
234	IDM 110D	110*130*16	IDI-110B		
235	IDM 112	112*125*9	ISI-112	UHR-112	
236	IDM 112A	112*127*9	IDI-112		
237	IDM 112B	112*127*10	IDI-112A		
238	IDM 112C	112*132*15	IDI-112B		
239	IDM 112D	112*132*16	IDI-112C		
240	IDM 115	115*130*9			
241	IDM 115A	115*135*12			D2-115A1
242	IDM 118	118*133*9	ISI-118		
243	IDM 118A	118*133*10	IDI-118		
244	IDM 118B	118*138*15	IDI-118A		
245	IDM 118C	118*138*16	IDI-118B		
246	IDM 120	120*135*9	ISI-120		D2-120
247	IDM 120A	120*135*10	IDI-120		
248	IDM 120B	120*140*12			D2-120A
249	IDM 120C	120*140*15	IDI-120A		
250	IDM 120D	120*140*16	IDI-120B		
251	IDM 125	125*140*9	ISI-125	UHR-125	
252	IDM 125A	125*140*10	IDI-125		
253	IDM 125B	125*140*15			
254	IDM 125C	125*145*12	IDI-125A		
255	IDM 125D	125*145*16	IDI-125B		
256	IDM 125E	125*150*19	IDI-125C		
257	IDM 125F	125*150*20	IDI-125D		
258	IDM 130	130*145*9	ISI-130		D2-130A
259	IDM 130A	130*145*10	IDI-130		
260	IDM 130B	130*150*12	IDI-130A		D2-130
261	IDM 130C	130*150*16	IDI-130B		
262	IDM 132	132*157*20	IDI-132		
263	IDM 135	135*155*12			
264	IDM 135A	135*160*19	IDI-135		
265	IDM 135B	135*160*20	IDI-135A		
266	IDM 136	136*150*8.5	ISI-136		
267	IDM 140	140*155*9	ISI-140	UHR-140	D2-140
268	IDM 140A	140*155*10	IDI-140		D2-140A
269	IDM 140B	140*160*12	IDI-140A		
270	IDM 140C	140*160*16	IDI-140B		
271	IDM 140D	140*165*15			
272	IDM 140E	140*165*19	IDI-140C		
273	IDM 140F	140*165*20	IDI-140D		
274	IDM 145	145*160*9	ISI-145		
275	IDM 145A	145*165*12			
276	IDM 145B	145*170*19	IDI-145		

服務源自專業…

序号	型号	规格	NOK	VALQUA	DZ
277	IDM 145C	145*170*20	IDI-145A		
278	IDM 150	150*165*9	ISI-150		
279	IDM 150A	150*165*10	IDI-150		
280	IDM 150B	150*170*12	IDI-150A		
281	IDM 150C	150*170*15			
282	IDM 150D	150*170*16	IDI-150B		
283	IDM 150E	150*175*16	IDI-150C		
284	IDM 150F	150*175*20	IDI-150D		
285	IDM 155	155*170*9	ISI-155		
286	IDM 155A	155*175*12			
287	IDM 155B	155*180*19	IDI-155		
288	IDM 155C	155*180*20	IDI-155A		
289	IDM 160	160*175*9	ISI-160	UHR-160	
290	IDM 160A	160*175*10	IDI-160		
291	IDM 160B	160*180*12	IDI-160A		
292	IDM 160C	160*180*16	IDI-160B		
293	IDM 160D	160*185*15			
294	IDM 160E	160*185*16	IDI-160C	UNR-160	D2-160
295	IDM 160F	160*185*19	IDI-160D		
296	IDM 160G	160*185*20	IDI-160E		
297	IDM 160H	160*190*19			
298	IDM 165	165*180*9	ISI-165		
299	IDM 165A	165*185*12			
300	IDM 170	170*185*9	ISI-170		
301	IDM 170A	170*185*10	IDI-170		
302	IDM 170B	170*190*12	IDI-170A		
303	IDM 170C	170*190*16	IDI-170B		
304	IDM 170D	170*195*16	IDI-170C	UNR-170	D2-170A
305	IDM 170E	170*195*20	IDI-170D		
306	IDM 175	175*190*9	ISI-175		
307	IDM 175A	175*200*15			
308	IDM 175B	175*200*19	IDI-175		
309	IDM 175C	175*200*20	IDI-175A		
310	IDM 180	180*200*12	ISI-180	UHR-180	D2-180A
311	IDM 180A	180*200*16	IDI-180		
312	IDM 180B	180*205*15			
313	IDM 180C	180*205*16	IDI-180A	UNR-180	D2-180
314	IDM 180D	180*205*19	IDI-180B		
315	IDM 180E	180*205*20	IDI-180C		
316	IDM 180F	180*210*19			
317	IDM 185	185*200*9			
318	IDM 190	190*210*12	ISI-190		
319	IDM 190A	190*210*16	IDI-190		
320	IDM 190B	190*215*15			
321	IDM 190C	190*215*16	IDI-190A	UNR-190	
322	IDM 190D	190*215*19	IDI-190B		

活赛杆密封

序号	型号	规格	NOK	VALQUA	DZ
323	IDM 199	199*219*11	IDI-199		
324	IDM 199A	199*219*15	IDI-199A		
325	IDM 199B	199*224*16	IDI-199B		
326	IDM 199C	199*224*19	IDI-199C		
327	IDM 200	200*220*12	ISI-200		
328	IDM 200A	200*220*16	IDI-200		
329	IDM 200B	200*225*15			
330	IDM 200C	200*225*16	IDI-200A	UNR-200	
331	IDM 200D	200*225*19	IDI-200B		
332	IDM 200E	200*225*20	IDI-200C		
333	IDM 200F	200*230*19			
334	IDM 204	204*224*12	ISI-204		
335	IDM 210	210*230*12	ISI-210		
336	IDM 210A	210*230*16	IDI-210		
337	IDM 210B	210*235*15			
338	IDM 210C	210*235*16	IDI-210A		
339	IDM 210D	210*235*19	IDI-210B		
340	IDM 210E	210*235*20	IDI-210C		
341	IDM 220	220*240*12	ISI-220		
342	IDM 220A	220*240*16	IDI-220		
343	IDM 220B	220*245*15			
344	IDM 220C	220*245*16	IDI-220A		
345	IDM 220D	220*245*19	IDI-220B		
346	IDM 220E	220*245*20	IDI-220C		
347	IDM 220F	220*250*19			D2-220
348	IDM 224	224*244*11	IDI-224		
349	IDM 224A	224*244*15	IDI-224A		
350	IDM 224B	224*249*15	IDI-224B		
351	IDM 224C	224*249*18	IDI-224C		
352	IDM 224D	224*249*19	IDI-224D	UNR-224	
353	IDM 225	225*245*12	ISI-225		
354	IDM 225A	225*245*16	IDI-225		
355	IDM 225B	225*250*16	IDI-225A		
356	IDM 225C	225*250*19	IDI-225B		
357	IDM 225D	225*250*20	IDI-225C		
358	IDM 230	230*250*12	ISI-230		
359	IDM 230A	230*250*16	IDI-230		
360	IDM 230B	230*255*16	IDI-230A		
361	IDM 230C	230*255*19	IDI-230B	UNR-230	
362	IDM 230D	230*255*20	IDI-230C		
363	IDM 240	240*260*12	ISI-240		
364	IDM 240A	240*260*16	IDI-240		
365	IDM 240B	240*265*16	IDI-240A		
366	IDM 240C	240*265*19	IDI-240B		
367	IDM 240D	240*265*20	IDI-240C		
368	IDM 250	250*270*12	ISI-250		

服務源自專業…

序号	型号	规格	NOK	VALQUA	DZ
369	IDM 250A	250*270*16	IDI-250		
370	IDM 250B	250*275*15			
371	IDM 250C	250*275*16	IDI-250A		
372	IDM 250D	250*275*19	IDI-250B	UNR-250	
373	IDM 250E	250*275*20	IDI-250C		
374	IDM 250F	250*280*19	IDI-250D		
375	IDM 260	260*285*16	ISI-260		
376	IDM 260A	260*285*19	IDI-260		
377	IDM 260B	260*290*19	IDI-260A		
378	IDM 265	265*297*24	IDI-265		
379	IDM 265A	265*297*25	IDI-265A		
380	IDM 270	270*295*16	ISI-270		
381	IDM 270A	270*295*19	IDI-270		
382	IDM 270B	270*300*19	IDI-270A	UNR-270	
383	IDM 270C	270*300*24	IDI-270B		
384	IDM 270D	270*300*25	IDI-270C		
385	IDM 280	280*305*16	ISI-280		
386	IDM 280A	280*305*19	IDI-280		
387	IDM 280B	280*310*19	IDI-280A	UNR-280	
388	IDM 280C	280*312*24	IDI-280B		
389	IDM 280D	280*312*25	IDI-280C		
390	IDM 290	290*315*16	ISI-290		
391	IDM 290A	290*315*19	IDI-290		
392	IDM 290B	290*320*19	IDI-290A		
393	IDM 300	300*325*16	ISI-300		
394	IDM 300A	300*325*19	IDI-300		
395	IDM 300B	300*330*19	IDI-300A		
396	IDM 300C	300*332*24	IDI-300B		
397	IDM 300D	300*332*25	IDI-300C		
398	IDM 320	320*350*19			
399	IDM 320A	320*360*25			

服務源自專業…

序号	型号	规格	NOK	VALQUA	DZ
43	UPM 23.5	23.5*31.5*5	USI-23.5	UHS-31.5	UN-23.5
44	UPM 25	25*33*5	USI-25	UHS-25	UN-25
45	UPM 25A	25*35*8	UPI-25	UNS-25	UN-25F
46	UPM 25B	25*38*8	UPI-25A		UN-25H
47	UPM 25C	25*38*10			UN-25I
48	UPM 25D	25*40*10	UPI-25B		UN-25J
49	UPM 25E	25*45*12	UPI-25C		
50	UPM 25.5	25.5*35.5*8	UPI-25.5		
51	UPM 27	27*40*10			
52	UPM 27.5	27.5*35.5*5			
53	UPM 28	28*35.5*5	UPI-28		UN-28
54	UPM 28A	28*36*5	USI-28A		UN-28A
55	UPM 28B	28*40*10	UPI-28A		UN-28B
56	UPM 28C	28*41*10			
57	UPM 28D	28*43*10	UPI-28B	UNS-28	UN-28C
58	UPM 30	30*40*6	USI-30A	UHS-30	UN-30D
59	UPM 30A	30*43*10			
60	UPM 30B	30*45*10	UPI-30		UN-30J
61	UPM 30C	30*46*10	UPI-30A		
62	UPM 31.5	31.5*41.5*6	USI-31.5	UHS-31.5	UN-31.5
63	UPM 31.5A	31.5*44.5*10			
64	UPM 31.5B	31.5*46.5*10	UPI-31.5		UN-31.5B
65	UPM 32	32*46*10	UPI-32		UN-32C
66	UPM 32A	32*48*10			UN-32E
67	UPM 34	34*50*12			UN-34
68	UPM 35	35*45*6	USI-35	UHS-35	UN-35
69	UPM 35A	35*50*10	UPI-35		UN-35F
70	UPM 35B	35*50*12			
71	UPM 35.5	35.5*45*6	USI-35.5	UHS-35.5	UN-35.5
72	UPM 35.5A	35.5*45.5*6			
73	UPM 35.5B	35.5*50.5*10	UPI-35.5	UNS-35.5	UN-35.5A
74	UPM 35.5C	35.5*51.5*12			
75	UPM 38	38*52*10	UPI-38		
76	UPM 40	40*50*6	USI-40	UHS-40	UN-40
77	UPM 40A	40*55*10	UPI-40	UNS-40	UN-40F
78	UPM 40B	40*56*10	UPI-40A		
79	UPM 40C	40*56*12			
80	UPM 40D	40*60*12	UPI-40B		UN-40H
81	UPM 41	41*56*10	UPI-41		
82	UPM 45	45*55*6	USI-45	UHS-45	UN-45A
83	UPM 45A	45*56*6			
84	UPM 45B	45*56*7	UPI-45		UN-45D

孔轴通用密封圈

序号	型号	规格	NOK	VALQUA	DZ
85	UPM 45C	45*60*10	UPI-45A	UNS-45	UN-45E
86	UPM 45D	45*61*10	UPI-45B		
87	UPM 45E	45*61*12			
88	UPM 46	46*60*10	UPI-46		
89	UPM 47	47*63*12			
90	UPM 48	48*63*10	UPI-48	UNS-48	UN-48
91	UPM 50	50*60*6	USI-50	UHS-50	UN-50A
92	UPM 50A	50*65*10	UPI-50	UNS-50	UN-50H
93	UPM 50B	50*66*12	UPI-50A		UN-50I
94	UPM 50C	50*70*12	UPI-50B		UN-50K
95	UPM 51	51*71*12	UPI-51		
96	UPM 53	53*63*6	USI-53	UHS-53	UN-53
97	UPM 55	55*73*12		UNS-55	
98	UPM 55A	55*65*6	USI-55	UHS-55	UN-55
99	UPM 55B	55*71*12	UPI-55		UN-55E
100	UPM 55C	55*75*12	UPI-55A	UNS-55	UN-55F
101	UPM 55D	55*80*15	UPI-55B		
102	UPM 56	56*66*6	USI-56	UHS-56	UN-56
103	UPM 56A	56*72*12	UPI-56		
104	UPM 56B	56*76*12	UPI-56A	UNS-56	UN-56A
105	UPM 58	58*78*12	UPI-58		
106	UPM 60	60*70*6	USI-60	UHS-60	UN-60
107	UPM 60A	60*71*7	UPI-60		UN-60D
108	UPM 60B	60*76*12			
109	UPM 60C	60*80*12	UPI-60A	UNS-60	UN-60I
110	UPM 62	62*82*12	UPI-62		
111	UPM 63	63*73*6	USI-63	UHS-63	UN-63
112	UPM 63A	63*83*12	UPI-63	UNS-63	UN-63C
113	UPM 64	64*80*12			UN-64
114	UPM 65	65*75*6	USI-65	UHS-65	UN-65
115	UPM 65A	65*85*12	UPI-65	UNS-65	UN-65D
116	UPM 67	67*77*6	USI-67	UHS-67	UN-67
117	UPM 67A	67*87*12	UPI-67	UNS-67	UN-67A
118	UPM 70	70*80*6	USI-70	UHS-70	UN-70
119	UPM 70A	70*90*12	UPI-70	UNS-70	UN-70G
120	UPM 70B	70*90*15			
121	UPM 71	71*80*6	USI-71	UHS-71	UN-71
122	UPM 71A	71*91*12	UPI-71A	UNS-71	UN-71A
123	UPM 75	75*85*6	USI-75	UHS-75	UN-75
124	UPM 75A	75*95*12	UPI-75	UNS-75	UN-75D
125	UPM 75B	75*95*15			
126	UPM 80	80*90*6	USI-80	UHS-80	UN-80

服務源自專業…

序号	型号	规格	NOK	VALQUA	DZ
127	UPM 80A	80*100*12	UPI-80	UNS-80	UN-80F
128	UPM 80B	80*100*15	UPI-80A		
129	UPM 85	85*100*9	USI-85	UHS-85	UN-85C
130	UPM 85A	85*105*12	UPI-85	UNS-85	UN-85E
131	UPM 85B	85*105*15			
132	UPM 90	90*105*9	USI-90	UHS-90	UN-90B
133	UPM 90A	90*110*12	UPI-90	UNS-90	UN-90D
134	UPM 90B	90*110*15			
135	UPM 95	95*110*9	USI-95	UHS-95	UN-95
136	UPM 95A	95*115*12	UPI-95	UNS-95	UN-95B
137	UPM 95B	95*115*15			
138	UPM 95C	95*120*15	UPI-95A		
139	UPM 98	98*112*8.5	USI-98		
140	UPM 98A	98*112*9	UPI-98	UHS-98	UN-98
141	UPM 100	100*115*9	USI-100	UHS-100	UN-100A
142	UPM 100A	100*120*12		UN-100	UN-100C
143	UPM 100B	100*120*15			
144	UPM 100C	100*125*15	UPI-100		UN-100E
145	UPM 105	105*125*15	UPI-105		UN-105B
146	UPM 106	106*120*8.5	USI-106		
147	UPM 106A	106*126*15	UPI-106		UN-106
148	UPM 110	110*130*15	UPI-110		UN-110C
149	UPM 112	112*125*9	USI-115	UHS-112	UN-112
150	UPM 112A	112*132*15	UPI-112		UN-112A
151	UPM 115	115*135*15	UPI-115		UN-115
152	UPM 118	118*132*8.5	USI-118		
153	UPM 118A	118*132*9	UPI-118		
154	UPM 118B	118*138*15	UPI-118A	UNS-118	
155	UPM 120	120*140*15	UPI-120		UN-120A
156	UPM 125	125*140*9	USI-125	UHS-125	UN-125
157	UPM 125A	125*145*15	UPI-125		UN-125B
158	UPM 130	130*150*15	UPI-130		UN-130A
159	UPM 132	132*145*8.5	USI-132		
160	UPM 132A	132*152*15	UPI-132		
161	UPM 135	135*155*15	UPI-135		
162	UPM 136	136*150*8.5	USI-136		
163	UPM 136A	136*150*9	UPI-136	UHS-136	UN-136
164	UPM 140	140*155*9		USH-140	UN-140
165	UPM 140A	140*160*15	UPI-140		
166	UPM 140B	140*165*15	UPI-140		
167	UPM 145	145*160*9	USI-145	USH-145	
168	UPM 145A	145*165*15	UPI-145		

防尘圈

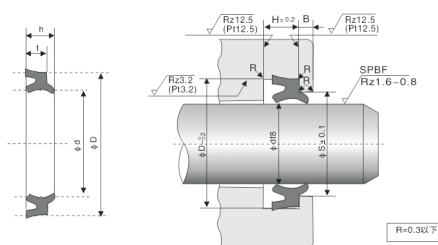

序号	型号	规格	NOK	VALQUA	DZ
1	LBM 11.2	11.2*19.2*4.5/6		DHS-11.2	DH11.2
2	LBM 12.5	12.5*20.2*4.6/6	LBI-12.5	DHS-12.5	
3	LBM 14	14*22*4.5/6	LBI-14	DHS-14	DH-14
4	LBM 16	16*24*4.5/6	LBI-16	DHS-16	DH-16
5	LBM 18	18*26*4.5/6	LBI-18	DHS-18	DH-18
6	LBM 20	20*28*4.5/6	LBI-20	DHS-20	DH-20
7	LBM 22	22*30*4.5/6	LBI-22		DH-22
8	LBM 22.4	22.4*30.4*4.5/6	LBI-22.4	DHS-22.4	DH-22.4
9	LBM 25	25*33*4.5/6	LBI-25	DHS-25	DH-25
10	LBM 28	28*36*4.5/6	LBI-28	DHS-28	DH-28
11	LBM 30	30*38*5/6.5	LBI-30	DHS-30	DH-30
12	LBM 31.5	31.5*39.5*5/6.5	LBI-31.5	DH-31.5	DH-31.5
13	LBM 35	35*43*5/6.5	LBI-35	DHS-35	DH-35
14	LBM 35.5	35.5*43.5*5/6.5	LBI-35.5	DHS-35.5	DH-35.5
15	LBM 40	40*48*5/6.5	LBI-40	DHS-40	DH-40
16	LBM 45	45*53*5/6.5	LBI-45	DHS-45	DH-45
17	LBM 50	50*58*5/6.5	LBI-50	DHS-50	DH-50
18	LBM 53	53*61*5/6.5	LBI-53	DHS-53	DH-53
19	LBM 55	55*63*5/6.5	LBI-55	DHS-55	DH-55
20	LBM 56	56*64*5/6.5	LBI-56	DHS-56	DH-56
21	LBM 60	60*68*5/6.5	LBI-60	DHS-60	DH-60
22	LBM 63	63*71*5/6.5	LBI-63	DHS-63	DH-63
23	LBM 65	65*73*5/6.5	LBI-65	DHS-65	DH-65
24	LBM 67	67*75*5/6.5	LBI-67	DHS-67	DH-67
25	LBM 70	70*80*6/8	LBI-70	DHS-70	DH-70
26	LBM 71	71*81*6/8	LBI-71	DHS-71	DH-71
27	LBM 75	75*85*6/8	LBI-75	DHS-75	DH-75
28	LBM 80	80*90*6/8	LBI-80	DHS-80	DH-80
29	LBM 85	85*95*6/8	LBI-85	DHS-85	DH-85
30	LBM 90	90*100*6/8	LBI-90	DHS-90	DH-90
31	LBM 95	95*105*6/8	LBI-95	DHS-95	DH-95
32	LBM 100	100*110*6/8	LBI-100	DHS-100	DH-100
33	LBM 105	105*115*6/8	LBI-105	DHS-105	DH-105
34	LBM 110	110*120*6/8	LBI-110		DH-110
35	LBM 112	112*122*6/8	LBI-112	DHS-112	DH-112
36	LBM 120	120*130*6/8			
37	LBM 125	125*138*7/9.5	LBI-125	DHS-125	DH-125
38	LBM 130	130*143*7/9.5			
39	LBM 132	132*145*7/9.5	LBI-132		DH-132
40	LBM 135	135*148*7/9.5			
41	LBM 140	140*153*7/9.5	LBI-140	DHS-140	DH-140
42	LBM145	145*158*7/9.5	LBI-145	DHS-145	DH-145

服務源自專業...

防尘圈Wiper

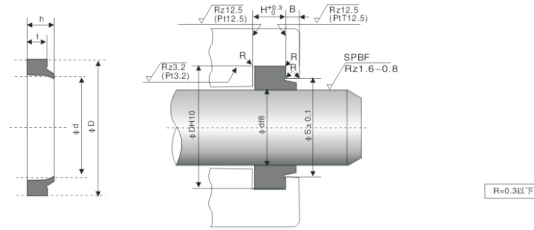

序号	型号	规格	NOK	VALQUA	DZ
1	DSM 6.3	6.3*14.3*4.5*6	DSI-6.3		
2	DSM 8	8*16*4.5*6	DSI-8		
3	DSM 9	9*17*4.5*6	DSI-9		
4	DSM 10	10*18*4.5*6	DSI-10		
5	DSM 11.2	11.2*19.2*4.5*6	DSI-11.2		
6	DSM 12.5	12.5*20.5*4.5*6	DSI-12.5		
7	DSM 14	14*22*4.5*6	DSI-14		
8	DSM 15	15*23*4.5*6	DSI-15		
9	DSM 16	16*24*4.5*6	DSI-16		
10	DSM 18	18*26*4.5*6	DSI-18		
11	DSM 20	20*28*4.5*6	DSI-20		
12	DSM 22.4	22.4*30.4*4.5*6	DSI-22.4		
13	DSM 22.4A	22.4*30.4*5*6.5			
14	DSM 23.5	23.5*31.5*4.5*6	DSI-23.5		
15	DSM 25	25*33*4.5*6	DSI-25		
16	DSM 25A	25*33*5*6.5			
17	DSM 28	28*36*4.5*6	DSI-28		
18	DSM 28A	28*36*5*6.5			
19	DSM 30	30*38*5*6.5	DSI-30		
20	DSM 30A	30*40*6*8			
21	DSM 31.5	31.5*39.5*5*6.5	DSI-31.5		
22	DSM 35	35*43*5*6.5	DSI-35		
23	DSM 35A	35*43*6*8			
24	DSM 35.5	35.5*43.5*5*6.5	DSI-35.5		
25	DSM 35.5A	35.5*43.5*6*8			
26	DSM 40	40*48*5*6.5	DSI-40		
27	DSM 40A	40*50*6*8			
28	DSM 45	45*53*5*6.5	DSI-45		
29	DSM 45A	45*55*6*8			
30	DSM 50	50*58*5*6.5	DSI-50		
31	DSM 50A	50*60*6*8			
32	DSM 53	53*61*5*6.5	DSI-53		
33	DSM 53A	53*63*6*8			
34	DSM 53B	53*66*7*9.5			
35	DSM 55	55*63*5*6.5	DSI-55		
36	DSM 55A	55*65*6*8			
37	DSM 55B	55*68*7*9.5			

防尘圈

序号	型号	规格	NOK	VALQUA	DZ
38	DSM 56	56*64*5*6.5	DSI-56		
39	DSM 56A	56*66*6*8			
40	DSM 56B	56*69*7*9.5			
41	DSM 60	60*68*5*6.5	DSI-60		
42	DSM 60A	60*73*7*9.5			
43	DSM 63	63*71*5*6.5	DSI-63		
44	DSM 63A	63*76*7*9.5			
45	DSM 65	65*73*5*6.5	DSI-65		
46	DSM 65A	65*78*7*9.5			
47	DSM 67	67*75*5*6.5	DSI-67		
48	DSM 67A	67*80*7*9.5			
49	DSM 70	70*80*6*8	DSI-70		
50	DSM 70A	70*83*7*9.5			
51	DSM 71	71*81*6*8	DSI-71		
52	DSM 71A	71*84*7*9.5			
53	DSM 75	75*85*6*8	DSI-75		
54	DSM 75A	75*88*7*9.5			
55	DSM 80	80*90*6*8	DSI-80		
56	DSM 80A	80*93*7*9.5			
57	DSM 85	85*95*6*8	DSI-85		
58	DSM 85A	85*98*7*9.5			
59	DSM 90	90*100*6*8	DSI-90		
60	DSM 90A	90*103*7*9.5			
61	DSM 95	95*105*6*8	DSI-95		
62	DSM 95A	95*108*7*9.5			
63	DSM 100	100*110*6*8	DSI-100		
64	DSM 100A	100*113*7*9.5			
65	DSM 105	105*115*6*8	DSI-105		
66	DSM 105A	105*118*7*9.5			
67	DSM 106	106*116*6*8	DSI-106		
68	DSM 106A	106*119*7*9.5			
69	DSM 110	110*1120*6*8	DSI-110		
70	DSM 110A	110*123*7*9.5			
71	DSM 112	112*122*6*8	DSI-112		
72	DSM 112A	112*125*7*9.5			
73	DSM 118	118*128*6*8	DSI-118		
74	DSM 120	120*130*6*8	SDI-120		

服務源自專業...

序号	型号	规格	NOK	VALQUA	DZ
75	DSM 120A	120*133*7*9.			
76	DSM 125	125*138*7*9.	DSI-125		
77	DSM 130	130*143*7*9.	DSI-130		
78	DSM 132	132*145*7*9.	DSI-132		
79	DSM 135	135*148*7*9.			
80	DSM 140	140*153*7*9.	DSI-140		
80	DSM 145	145*158*7*9.	DSI-145		
81	DSM 150	150*163*7*9.	DSI-150		
82	DSM 155	155*168*7*9.	DSI-155		
83	DSM 160	160*173*7*9.	DSI-160		
84	DSM 170	170*183*7*9.	DSI-170		
85	DSM 175	175*188*7*9.	DSI-175		
86	DSM 180	180*193*7*9.	DSI-180		
87	DSM 185	185*198*7*9.	DSI-185		
88	DSM 190	190*203*7*9.	DSI-190		
89	DSM 199	199*212*7*9.	DSI-199		
90	DSM 200	200*213*7*9.	DSI-200		
91	DSM 204	204*217*7*9.	DSI-204		
92	DSM 210	210*223*7*9.	DSI-210		
93	DSM 210A	210*226*9*12			
94	DSM 220	220*233*7*9.	DSI-220		
95	DSM 220A	220*236*9*12			
96	DSM 224	224*237*7*9.	DSI-224		
97	DSM 225	225*238*7*9.	DSI-225		
98	DSM 230	230*243*7*9.	DSI-230		
99	DSM 230A	230*246*9*12			
100	DSM 250	250*263*7*9.	DSI-250		
101	DSM 250A	250*266*9*12			
102	DSM 260	260*275*9*12			
103	DSM 260A	260*276*9*12			
104	DSM 270	270*285*9*12			
105	DSM 270A	270*286*9*12			
106	DSM 280	280*295*9*12			
107	DSM 280A	280*296*9*12			
108	DSM 290	290*305*9*12			
109	DSM 290A	290*306*9*12			
110	DSM 300	300*315*9*12			
111	DSM 300A	300*316*9*12			

骨架防尘圈

DKB 系列

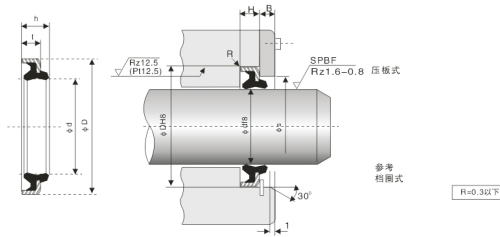

型号	规格
DKB	12.5*19*3/5
DKB	14*24*5/7
DKB	16*26*5/7
DKB	18*30*6/9
DKB	19*26*5/7
DKB	19*31*6/9
DKB	19*32*6/9
DKB	20*30*4/6
DKB	20*32*6/9
DKB	22*32*6/9
DKB	22*34*6/9
DKB	22.4*34.4*6/9
DKB	25*37*6/9
DKB	28*38*7/10
DKB	28*40*6/9
DKB	30*42*6/9
DKB	30*45*6/9
DKB	30*47*7/10
DKB	31.5*44*7/10
DKB	32*44*7/10
DKB	32*45*5/8
DKB	32*45*7/10
DKB	32*52*8/11
DKB	35*47*7/10
DKB	35.5*47.5*7/10
DKB	36*48*7/10
DKB	38*50*7/10
DKB	40*50*7/10
DKB	40*52*7/10
DKB	44.45*60.2*7.1/9
DKB	45*57*7/10
DKB	50*62*7/10
DKB	50*72*8/11
DKB	55*65*7/10
DKB	55*69*8/11

型号	规格
DKB	56*70*8/11
DKB	60*74*8/11
DKB	63*77*8/11
DKB	65*79*8/11
DKB	70*84*8/11
DKB	70*90*10/14
DKB	75*89*8/11
DKB	80*94*8/11
DKB	85*99*8/11
DKB	90*104*8/11
DKB	95*109*8/11
DKB	100*114*8/11
DKB	105*121*9/12
DKB	110*125*9/12
DKB	112*128*9/12
DKB	115*131*9/12
DKB	120*136*9/12
DKB	125*141*9/12
DKB	130*148*9/12
DKB	140*160*10/14
DKB	145*165*10/14
DKB	150*170*10/14
DKB	155*175*10/14
DKB	160*180*10/14
DKB	170*190*10/14
DKB	175*195*10/14
DKB	180*205*10/14
DKB	190*215*12/17
DKB	200*225*12/17
DKB	210*250*12/17
DKB	220*245*12/17
DKB	225*250*12/17
DKB	230*255*12/17
DKB	240*265*12/17
DKB	250*275*12/17

服務源自專業...

GA系列

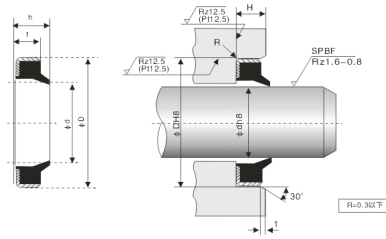

型号	规格
GA	10*16*3/4.5
GA	10*20*5/8
GA	10*26*5/8
GA	10*20*4/6
GA	12*20*4/6
GA	12*22*5/8
GA	14*20*3.5/5
GA	14*20*4/5
GA	14*22*3/4
GA	15*25*5/8
GA	16*22*3/4
GA	16*26*5/8
GA	18*28*7/10
GA	18*35*5/8
GA	20*26*5/8
GA	20*28*3/5
GA	20*28*5/8
GA	20*30*4/6
GA	20*30*7/10
GA	20*32*5/8
GA	20*35*7/10
GA	22*28*5/8
GA	22*32*5/8
GA	22*32*7/10
GA	22*35*5/8
GA	24*32*5/7
GA	25*31*5/7
GA	25*35*5/8
GA	25*37*7/10
GA	28*38*5/8
GA	28*38*7/10
GA	28*40*7/10
GA	30*40*5/8
GA	30*40*7/10
GA	30*42*5/7
GA	32*42*7/10
GA	32*45*5/8
GA	32*45*7/10
GA	35*41*5/7
GA	35*45*5/8
GA	35*45*7/10
GA	35*52*7/10

型号	规格
GA	36*45*5/7
GA	36*45*7/10
GA	36*46*7/10
GA	37*47*5/8
GA	38*53*5/8
GA	40*50*5/8
GA	40*50*7/10
GA	40*52*5/7
GA	42*52*7/10
GA	45*53*5/8
GA	45*55*7/10
GA	45*60*7/10
GA	48*60*7/10
GA	50*56*5/7
GA	50*60*7/10
GA	50*65*5/8
GA	50*65*7/10
GA	50*70*7/10
GA	52*62*7/10
GA	55*63*7/10
GA	55*65*7/10
GA	56*65*7/10
GA	56*66*5/8
GA	56*66*7/10
GA	60*70*7/10
GA	63*73*7/10
GA	63*75*7/10
GA	65*75*7/10
GA	70*80*7/10
GA	75*85*7/10
GA	80*88*7/10
GA	80*90*7/10
GA	80*94*7/10
GA	82*92*7/10
GA	85*95*7/10
GA	85*105*9/11
GA	90*100*7/10
GA	95*105*7/10
GA	100*110*7/10
GA	100*115*9/12
GA	105*115*7/10
GA	105.5*115*7/10
GA	108*120*7/10

型号	规格
GA	110*120*7/10
GA	110*125*9/12
GA	110*130*7/10
GA	115*125*7/10
GA	120*130*7/10
GA	125*135*7/10
GA	125*140*9/12
GA	125*141*9/12
GA	130*140*7/10
GA	130*145*9/12
GA	132*145*9/12
GA	135*150*7/10
GA	135*150*9/12
GA	140*155*9/12
GA	145*160*9/12
GA	145*165*9/12
GA	150*165*9/12
GA	160*175*9/12
GA	165*180*9/12
GA	170*185*9/12
GA	170*185*10/14
GA	175*190*10/14
GA	180*195*10/14
GA	185*200*10/14
GA	200*215*9/13
GA	200*220*10/14
GA	200*220*12/16
GA	210*230*10/15
GA	210*230*12/16
GA	220*235*10/14
GA	220*240*12/16
GA	225*250*12/16
GA	240*260*12/16
GA	250*265*10/16
GA	250*270*12/16
GA	260*290*12/16
GA	270*290*12/16
GA	270*295*12/16
GA	280*300*12/16
GA	300*320*12/16
GA	320*340*12/16
GA	350*370*12/16
GA	360*380*15/18

斯特封

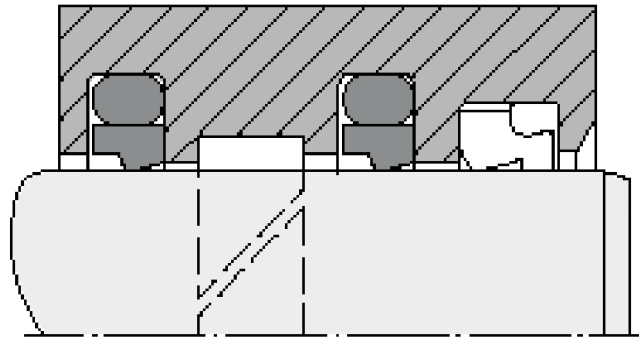

拉杆直径	沟槽外径	沟槽宽度	公称型号 (B+S)	O圈型号
df8	BH9	F+0.2		
4	8.9	2.2	GS55013-0040	5.6*1.8
5	9.9	2.2	GS55013-0050	6.7*1.8
6	10.9	2.2	GS55013-0060	AS-011
8	15.3	3.2	GS55013-0080	AS-111
10	14.9	2.2	GS55015-0100	11.8*1.8
10	17.3	3.2	GS55013-0100	AS-112
12	16.9	2.2	GS55015-0120	AS-015
12	19.3	3.2	GS55013-0120	AS-113
14	18.9	2.2	GS55015-0140	AS-016
14	21.3	3.2	GS55013-0140	AS-115
15	19.9	2.2	GS55015-0150	AS-017
15	22.3	3.2	GS55013-0150	AS-115
16	20.9	2.2	GS55015-0160	AS-017
16	23.3	3.2	GS55013-0160	AS-116
18	22.9	2.2	GS55015-0180	AS-018
18	25.3	3.2	GS55013-0180	AS-117
19	29.7	4.2	GS55013-0190	AS-213
20	27.3	3.2	GS55015-0200	AS-118
20	30.7	4.2	GS55013-0200	AS-213
22	29.3	3.2	GS55015-0220	AS-120
22	32.7	4.2	GS55013-0220	AS-215
25	32.3	3.2	GS55015-0250	AS-121
25	35.7	4.2	GS55013-0250	AS-217
28	35.3	3.2	GS55015-0280	AS-123
28	38.7	4.2	GS55013-0280	AS-219

拉杆直径	沟槽外径	沟槽宽度	公称型号 (B+S)	O圈型号
df8	BH9	F+0.2		
30	37.3	3.2	GS55015-0300	AS-125
30	40.7	4.2	GS55013-0300	AS-220
32	39.3	3.2	GS55015-0320	AS-126
32	42.7	4.2	GS55013-0320	AS-221
35	42.3	3.2	GS55015-0350	AS-128
35	45.7	4.2	GS55013-0350	AS-222
36	43.3	3.2	GS55015-0360	AS-129
36	46.7	4.2	GS55013-0360	AS-223
38	48.7	4.2	GS55015-0380	AS-223
38	53.1	6.3	GS55013-0380	AS-327
40	50.7	4.2	GS55015-0400	AS-224
40	55.1	6.3	GS55013-0400	AS-327
42	52.7	4.2	GS55015-0420	AS-225
42	57.1	6.3	GS55013-0420	AS-328
45	55.7	4.2	GS55015-0450	AS-226
45	60.1	6.3	GS55013-0450	AS-329
48	58.7	4.2	GS55015-0480	51.5*3.55
48	63.1	6.3	GS55013-0480	AS-330
50	60.7	4.2	GS55015-1500	AS-227
50	65.1	6.3	GS55013-0500	AS-331
55	65.7	4.2	GS55015-0500	AS-229
55	70.1	6.3	GS55013-0550	AS-332
56	66.7	4.2	GS55015-0560	AS-229
56	71.1	6.3	GS55013-0560	AS-333
56	76.5	8.1	GS55011-0560	63*7.0

服務源自專業...

拉杆直径	沟槽外径	沟槽宽度	公称型号 (B+S)	O圈型号
df8	BH9	F+0.2		
60	70.7	4.2	GS55015-0600	AS-230
60	75.1	6.3	GS55013-0600	AS-334
63	73.7	4.2	GS55015-0630	AS-231
63	78.1	6.3	GS55015-0630	AS-335
65	75.7	4.2	GS55013-0650	AS-232
65	80.1	6.3	GS55015-0650	AS-335
70	80.7	4.2	GS55015-0700	AS-234
70	85.1	6.3	GS55013-0700	AS-337
70	90.5	8.1	GS55011-0700	78*7.0
75	85.7	4.2	GS55015-0750	AS-235
75	90.1	6.3	GS55013-0750	AS-339
80	90.7	4.2	GS55015-0800	AS-237
80	95.1	6.3	GS55015-0800	AS-340
80	100.5	8.1	GS55011-0800	88*7.0
85	95.7	4.2	GS55015-0850	AS-238
85	100.1	6.3	GS55013-0850	AS-342
85	105.5	8.1	GS55011-0850	93*7.0
90	100.7	4.2	GS55015-0900	AS-240
90	105.1	6.3	GS55013-0900	AS-343
90	110.5	8.1	GS55011-0900	98*7.0
95	105.7	4.2	GS55015-0950	AS-242
95	110.1	6.3	GS55013-0950	AS-345
100	110.7	4.2	GS55015-1000	AS-243
100	115.1	6.3	GS55013-1000	AS-347
100	120.5	8.1	GS55011-1000	108*7.0
105	120.1	6.3	GS55013-1050	AS-348
105	125.5	8.1	GS55011-1050	AS-425
110	120.7	4.2	GS55015-1100	AS-246
110	125.1	6.3	GS55013-1100	AS-350
110	130.5	8.1	GS55011-1100	AS-426
115	130.1	6.3	GS55013-1150	AS-351
120	135.1	6.3	GS55013-1200	AS-353
120	140.5	8.1	GS55011-1200	AS-430
125	140.1	6.3	GS55013-1250	AS-354
125	145.5	8.1	GS55011-1250	AS-431
130	145.1	6.3	GS55013-1300	AS-356
130	150.5	8.1	GS55011-1300	AS-433
140	150.7	4.2	GS55015-1400	AS-256

斯特封

拉杆直径	沟槽外径	沟槽宽度	公称型号 (B+S)	O圈型号
df8	BH9	F+0.2		
140	155.1	6.3	GS55013-1400	AS-359
140	160.5	8.1	GS55011-1400	AS-436
145	160.1	6.3	GS55013-1450	AS-361
145	165.5	8.1	GS55011-1450	AS-437
150	165.1	6.3	GS55013-1500	AS-362
150	170.5	8.1	GS55011-1500	AS-438
160	175.1	6.3	GS55013-1600	AS-363
160	180.5	8.1	GS55011-1600	AS-440
165	180.5	6.3	GS55013-1650	AS-364
170	185.1	6.3	GS55013-1700	AS-365
170	190.5	8.1	GS55011-1700	AS-441
175	190.1	6.3	GS55013-1750	AS-366
180	195.1	6.3	GS55013-1800	AS-366
180	200.5	8.1	GS55011-1800	AS-443
185	200.1	6.3	GS55013-1850	AS-367
185	205.5	8.1	GS55011-1850	AS-444
190	205.1	6.3	GS55013-1900	AS-368
190	210.5	8.1	GS55011-1900	AS-444
195	210.1	6.3	GS55013-1950	AS-369
200	215.1	6.3	GS55015-2000	AS-370
200	220.5	8.1	GS55013-2000	AS-445
205	225.5	8.1	GS55013-2050	AS-446
210	230.5	8.1	GS55013-2100	AS-446
215	235.5	8.1	GS55013-2150	AS-447
220	240.5	8.1	GS55013-2200	AS-447
225	245.5	8.1	GS55013-2250	AS-448
230	245.1	6.3	GS55015-2300	AS-374
230	250.5	8.1	GS55013-2300	AS-448
235	255.5	8.1	GS55013-2350	AS-448
240	260.5	8.1	GS55013-2400	AS-449
245	265.5	8.1	GS55013-2450	AS-449
250	270.5	8.1	GS55013-2500	AS-450
260	284	8.1	GS55013-2600	AS-450
265	289	8.1	GS55013-2650	AS-451
270	290.5	8.1	GS55015-2700	AS-451
270	294	8.1	GS55013-2700	AS-451
275	299	8.1	GS55013-2750	AS-452
280	304	8.1	GS55013-2800	AS-452

服務源自專業...

拉杆直径	沟槽外径	沟槽宽度	公称型号 (B+S)	O圈型号
df8	BH9	F+0.2		
285	309	8.1	GS55013-2850	AS-452
290	314	8.1	GS55013-2900	AS-453
295	319	8.1	GS55013-2950	AS-453
300	320.5	8.1	GS55015-3000	AS-453
300	324	8.1	GS55013-3000	AS-453
310	334	8.1	GS55013-3100	AS-454
320	344	8.1	GS55013-3200	AS-455
330	354	8.1	GS55013-3300	AS-456
340	364	8.1	GS55013-3400	AS-457
350	374	8.1	GS55013-3500	AS-458
360	384	8.1	GS55013-3600	AS-458
365	389	8.1	GS55013-3650	AS-459
370	394	8.1	GS55013-3700	AS-459
375	399	8.1	GS55013-3750	AS-460
380	404	8.1	GS55013-3800	AS-460
390	414	8.1	GS55013-3900	AS-461
400	424	8.1	GS55013-4000	AS-462
410	434	8.1	GS55013-4100	AS-462
420	444	8.1	GS55013-4200	AS-463
430	454	8.1	GS55013-4300	AS-464
435	459	8.1	GS55013-4350	AS-464
440	464	8.1	GS55013-4400	AS-465
450	474	8.1	GS55013-4500	AS-466
460	484	8.1	GS55013-4600	AS-466
470	494	8.1	GS55013-4700	AS-467
480	504	8.1	GS55013-4800	AS-468
485	509	8.1	GS55013-4850	AS-468
490	514	8.1	GS55013-4900	AS-469
500	524	8.1	GS55013-5000	AS-469
510	534	8.1	GS55013-5100	AS-470
520	544	8.1	GS55013-5200	AS-470
530	554	8.1	GS55013-5300	AS-471
540	564	8.1	GS55013-5400	AS-471
550	574	8.1	GS55013-5500	AS-471
560	584	8.1	GS55013-5600	AS-472
580	604	8.1	GS55013-5800	AS-475
600	624	8.1	GS55013-6000	AS-475
610	634	8.1	GS55013-6100	633*7.0

格莱圈

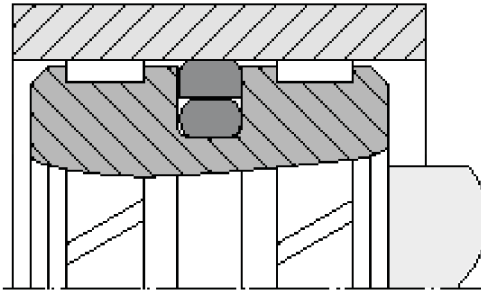

缸径	沟槽 外径	沟槽 宽度	公称型号 (B+S)	O圈型号
Dh9	Bh9	F+0.2		
8	3.1	2.2	GS55044-0080	AS-006
10	5.1	2.2	GS55044-0100	4.8*1.8
14	9.1	2.2	GS55044-0140	8.8*1.8
15	10.1	2.2	GS55046-0150	9.8*1.8
15	7.5	3.2	GS55044-0150	AS-109
16	11.1	2.2	GS55046-0160	AS-013
16	8.5	3.2	GS55044-0160	AS-109
18	13.1	2.2	GS55046-0180	AS-014
18	10.5	3.2	GS55044-0180	AS-110
20	15.1	2.2	GS55046-0200	AS-015
20	12.5	3.2	GS55044-0200	AS-112
24	19.1	2.2	GS55046-0240	AS-018
24	16.5	3.2	GS55044-0240	AS-114
25	17.5	3.2	GS55044-0250	AS-115
25	14	4.2	GS55042-0250	AS-207
28	20.5	3.2	GS55044-0280	AS-117
28	17	4.2	GS55042-0280	AS-209
30	22.5	3.2	GS55044-0320	AS-118
30	19	4.2	GS55042-0300	AS-210
32	24.5	3.2	GS55044-0320	AS-119
32	21	4.2	GS55042-0320	AS-211
35	27.5	3.2	GS55044-0350	AS-121
35	24	4.2	GS55042-0350	AS-213
36	28.5	3.2	GS55044-0360	AS-122
36	25	4.2	GS55042-0360	AS-214
38	30.5	3.2	GS55044-0380	AS-123

缸径	沟槽 外径	沟槽 宽度	公称型号 (B+S)	O圈型号
Dh9	Bh9	F+0.2		
38	27	4.2	GS55042-0380	AS-215
40	32.5	3.2	GS55046-0400	AS-124
40	29	4.2	GS55044-0400	AS-216
45	37.5	3.2	GS55046-0450	AS-127
45	34	4.2	GS55044-0450	AS-219
48	40.5	3.2	GS55046-0480	AS-129
48	37	4.2	GS55044-0480	AS-221
50	39	4.2	GS55044-0500	AS-222
50	34.5	6.3	GS55042-0500	AS-323
52	41	4.2	GS55044-0520	AS-223
52	36.5	6.3	GS55042-0520	35*5.3
55	44	4.2	GS55044-0550	AS-224
55	39.5	6.3	GS55042-0550	AS-325
56	45	4.2	GS55044-0560	AS-224
56	40.5	6.3	GS55042-0560	39*5.3
60	49	4.2	GS55044-0600	AS-225
60	44.5	6.3	GS55042-0600	AS-327
63	52	4.2	GS55044-0630	AS-226
63	47.5	6.3	GS55042-0630	AS-328
64	53	4.2	GS55044-0640	52*3.5
64	48.5	6.3	GS55042-0640	AS-328
65	54	4.2	GS55044-0650	AS-227
65	49.5	6.3	GS55042-0650	48*5.3
70	59	4.2	GS55044-0700	AS-228
70	54.5	6.3	GS55042-0700	AS-330
75	64	4.2	GS55044-0750	AS-230

服務源自專業...

缸径	沟槽外径	沟槽宽度	公称型号 (B+S)	O圈型号
Dh9	Bh9	F+0.2		
75	59.5	6.3	GS55042-0750	AS-331
80	69	4.2	GS55046-0800	AS-231
80	64.5	6.3	GS55044-0800	AS-333
85	74	4.2	GS55046-0850	73*3.5
85	69.5	6.3	GS55044-0850	AS-335
90	79	4.2	GS55046-0900	AS-235
90	74.5	6.3	GS55044-0900	AS-336
95	84	4.2	GS55046-0950	84*3.5
95	79.5	6.3	GS55044-0950	AS-338
100	89	4.2	GS55046-1000	AS-238
100	84.5	6.3	GS55044-1000	AS-339
105	94	4.2	GS55046-1050	AS-239
105	89.5	6.3	GS55044-1050	AS-341
110	99	4.2	GS55046-1100	AS-241
110	94.5	6.3	GS55044-1100	AS-342
115	99.5	6.3	GS55044-1150	AS-344
120	104.5	6.3	GS55044-1200	AS-345
125	109.5	6.3	GS55044-1250	AS-347
125	104	8.1	GS55042-1250	103*7.0
130	114.5	6.3	GS55044-1300	AS-349
130	109	8.1	GS55042-1300	108*7.0
135	119.5	6.3	GS55046-1350	118*5.3
135	114	8.1	GS55044-1350	AS-425
140	124.5	6.3	GS55046-1400	AS-352
140	119	8.1	GS55044-1400	AS-426
145	124	8.1	GS55044-1450	AS-428
150	129	8.1	GS55044-1500	AS-429
155	134	8.1	GS55044-1550	AS-431
160	139	8.1	GS55044-1600	AS-432
165	144	8.1	GS55044-1650	AS-434
170	149	8.1	GS55044-1700	AS-435
175	154	8.1	GS55044-1750	AS-437
180	159	8.1	GS55044-1800	AS-438
190	169	8.1	GS55044-1900	AS-439
200	179	8.1	GS55044-2000	AS-441
210	189	8.1	GS55044-2100	AS-442
220	199	8.1	GS55044-2200	AS-444
230	209	8.1	GS55044-2300	209*7.0

格莱圈

缸径	沟槽外径	沟槽宽度	公称型号 (B+S)	O圈型号
Dh9	Bh9	F+0.2		
240	219	8.1	GS55044-2400	AS-446
250	229	8.1	GS55044-2500	AS-447
260	239	8.1	GS55044-2600	AS-448
270	249	8.1	GS55044-2700	AS-448
275	254	8.1	GS55044-2750	AS-449
280	259	8.1	GS55044-2800	AS-449
290	269	8.1	GS55044-2900	AS-450
300	279	8.1	GS55044-3000	AS-451
310	289	8.1	GS55044-3100	AS-451
320	299	8.1	GS55044-3200	AS-452
330	305.5	8.1	GS55044-3300	AS-453
340	315.5	8.1	GS55044-3400	AS-454
350	325.5	8.1	GS55044-3500	AS-454
360	335.5	8.1	GS55044-3600	AS-455
370	345.5	8.1	GS55044-3700	AS-456
380	355.5	8.1	GS55044-3800	AS-457
390	365.5	8.1	GS55044-3900	360*7.0
400	375.5	8.1	GS55044-4000	AS-458
410	385.5	8.1	GS55044-4100	AS-459
420	395.5	8.1	GS55044-4200	AS-460
430	405.5	8.1	GS55044-4300	AS-461
435	410.5	8.1	GS55044-4350	405*7.0
440	415.5	8.1	GS55044-4400	AS-461
450	425.5	8.1	GS55044-4500	AS-462
460	435.5	8.1	GS55044-4600	AS-463
470	445.5	8.1	GS55044-4700	AS-464
480	455.5	8.1	GS55044-4800	AS-465
490	465.5	8.1	GS55044-4900	460*7.0
500	475.5	8.1	GS55044-5000	AS-466
510	485.5	8.1	GS55044-5100	AS-467
520	495.5	8.1	GS55044-5200	AS-468
530	505.5	8.1	GS55044-5300	AS-468
540	515.5	8.1	GS55044-5400	AS-469
550	525.5	8.1	GS55044-5500	AS-469
560	535.5	8.1	GS55044-5600	AS-470
570	545.5	8.1	GS55044-5700	AS-470
580	555.5	8.1	GS55044-5800	550*7.0
600	575.5	8.1	GS55044-6000	AS-471
610	585.5	8.1	GS55044-6100	AS-472

抗磨环及支撑环Wearing

在液压油缸、气缸中，抗磨环、耐磨环、支撑（承）环的基本作用都是一样的，精确的导向作用和缓解径向力，同时防止缸内滑动部件的金属件接触磨损。与金属耐磨环比较，非金属耐磨环有以下优点：

- 1、优良的耐磨特性；
- 2、避免金属间的接触；
- 3、抑制缸体的冲击振动；
- 4、基于耐磨环的对中作用，允许较大的径向间隙存在；
- 5、沟槽结构简单，易于安装；

耐磨环常用材料：

- 1、PTFE添加青铜、二硫化钼、纤维。一般成卷供应。
- 2、聚甲醛合成纤维。成卷供应或单件供应。
- 3、酚醛树脂合成纤维。成卷供应或单件供应。

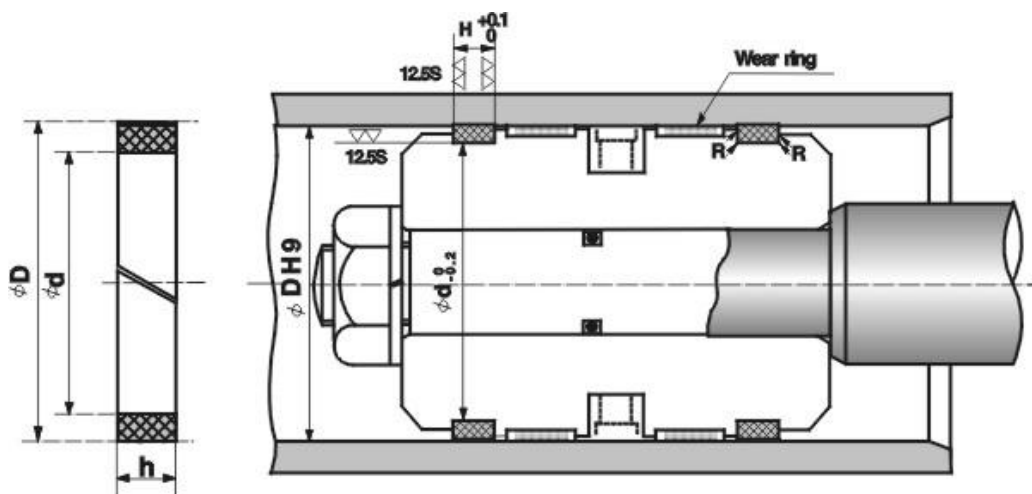

抗磨环及支撑环

PWR抗磨环：酚醛夹布树脂材质

规格	内径	外径	宽度
WR-018	14.00	18.00	8.00
WR-019.2	15.200	19.200	8.00
WR-020	16.00	20.00	8.00
WR-022	18.00	22.00	8.00
WR-024	20.00	24.00	8.00
WR-025	21.00	25.00	8.00
WR-026	22.00	26.00	8.00
WR-028	24.00	28.00	8.00
WR-030	26.00	30.00	8.00
WR-031	27.00	31.00	8.00
WR-031.5	27.50	31.50	8.00
WR-033	29.00	33.00	10.00
WR-035	31.00	35.00	10.00
WR-035.4	31.40	35.40	10.00
WR-035.5	31.50	35.50	10.00
WR-038	34.00	38.00	10.00
WR-040	36.00	40.00	10.00
WR-041	37.00	41.00	15.00
WR-043	38.00	43.00	15.00
WR-044.5	39.50	44.50	15.00
WR-045	40.00	45.00	15.00
WR-050	45.00	50.00	15.00
WR-051.5	46.50	51.50	15.00
WR-055	50.00	55.00	15.00
WR-056	51.00	56.00	15.00
WR-060	55.00	60.00	15.00
WR-061	56.00	61.00	15.00
WR-063	58.00	63.00	15.00
WR-065	60.00	65.00	20.00
WR-066	61.00	66.00	20.00
WR-069	64.00	69.00	20.00
WR-070	65.00	70.00	20.00
WR-071	66.00	71.00	20.00
WR-075	70.00	75.00	20.00
WR-076	71.00	76.00	20.00
WR-080	75.00	80.00	20.00
WR-085	85.00	79.00	25.00

规格	内径	外径	宽度
WR-090	84.00	90.00	25.00
WR-095	89.00	95.00	25.00
WR-100	94.00	100.00	25.00
WR-105	99.00	105.00	25.00
WR-110	104.00	110.00	25.00
WR-112	106.00	112.00	30.00
WR-115	109.00	115.00	30.00
WR-120	114.00	120.00	30.00
WR-125	119.00	125.00	30.00
WR-130	123.00	130.00	30.00
WR-132	125.00	132.00	35.00
WR-140	133.00	140.00	35.00
WR-150	143.00	150.00	35.00
WR-157	150.00	157.00	40.00
WR-160	153.00	160.00	40.00
WR-165	157.00	165.00	45.00
WR-170	162.00	170.00	45.00
WR-180	172.00	180.00	45.00
WR-185	177.00	185.00	45.00
WR-190	182.00	190.00	45.00
WR-200	192.00	200.00	45.00
WR-205	197.00	205.00	50.00
WR-210	202.00	210.00	50.00
WR-220	212.00	220.00	50.00
WR-224	216.00	224.00	50.00
WR-225	217.00	225.00	50.00
WR-230	222.00	230.00	55.00
WR-240	232.00	240.00	55.00
WR-250	242.00	250.00	55.00
WR-260	252.00	260.00	60.00
WR-270	262.00	270.00	60.00
WR-275	267.00	275.00	60.00
WR-290	282.00	290.00	70.00
WR-297	289.00	297.00	70.00
WR-300	292.00	300.00	70.00
WR-312	304.00	312.00	70.00
WR-332	324.00	332.00	70.00

服務源自專業...

耐磨环（带）：材质-PTFE+BRONZ+MuS2+GLASS

产品规格	宽度	厚度	备注
GT-3.2	3.2	1.50	
GT-3.2A	3.2	2.00	
GT-4.2	4.2	2.50	
GT-4.2A	4.2	2.00	
GT-4.2B	4.2	2.50	
GT-4.2C	4.2	3.00	
GT-5.6	5.6	1.50	
GT-5.6A	5.6	2.00	BS50703
GT-5.6B	5.6	2.50	
GT-5.6C	5.6	3.00	
GT-6.3	6.3	1.50	
GT-6.3A	6.3	2.00	
GT-6.3B	6.3	2.50	
GT-6.3C	6.3	3.00	
GT-8.1	8.1	1.50	
GT-8.1A	8.1	2.00	
GT-8.1B	8.1	2.50	
GT-8.1C	8.1	3.00	
GT-9.7	9.7	1.50	
GT-9.7A	9.7	2.00	
GT-9.7B	9.7	2.50	BS50704
GT-9.7C	9.7	3.00	
GT-15	15	1.50	BS50705
GT-15A	15	2.00	

产品规格	宽度	厚度	备注
GT-15B	15	2.50	
GT-15C	15	3.00	BS50705
GT-15D	15	4.00	
GT-20	20	1.50	
GT-20A	20	2.00	
GT-20B	20	2.50	
GT-20C	20	3.00	
GT-20D	20	4.00	
GT-25	25	1.50	
GT-25A	25	2.00	
GT-25B	25	2.50	BS50706
GT-25C	25	3.00	
GT-25D	25	4.00	
GT-30	30	1.50	
GT-30A	30	2.00	
GT-30B	30	2.50	
GT-30C	30	3.00	
GT-30D	30	4.00	
GT-40	40	1.50	
GT-40A	40	2.00	
GT-40B	40	2.50	
GT-40C	40	3.00	
GT-40D	40	4.00	

活塞杆衬套

BUSHING 开口型Atraight Joint

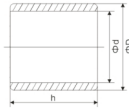

ITEM	Part.No	Shaft Dia.	Housing Dia.	Length
1	DU3015	30	34	15
2	DU3020			20
3	DU3025			25
4	DU3030			30
5	DU3040			40
6	DU3520	35	39	20
7	DU3525			25
8	DU3530			30
9	DU4020	40	44	20
10	DU4025			25
11	DU4030			30
12	DU4035			35
13	DU4040			40
14	DU4530	45	50	30
15	DU4535			35
16	DU5035	50	55	35
17	DU5040			40
18	DU6030	60	65	30
19	DU6035			35
20	DU6040			40
21	DU6530	65	70	30
22	DU6535			35
23	DU6540			40
24	DU6560			60
25	DU7030	70	75	30
26	DU7035			35
27	DU7040			40
28	DU7530	75	80	30
29	DU7535			35
30	DU7540			40
31	DU8030	80	85	30
32	DU8035			35
33	DU8040			40
34	DU8060			60
35	DU8530	85	90	30
36	DU8535			35
37	DU8540			40
38	DU8550			50
39	DU8560			60

服務源自專業...

ITEM	Part.No	Shaft Dia.	Housing Dia.	Length
40	DU9030	90	95	30
41	DU9035			35
42	DU9040			40
43	DU9045			45
44	DU9050			50
45	DU9060			60
46	DU9530	95	100	30
47	DU9535			35
48	DU9540			40
49	DU9550			50
50	DU9560			60
51	DU10030	100	105	30
52	DU10035			35
53	DU10040			40
54	DU10045			45
55	DU10050			50
56	DU10060			60
57	DU10535	105	110	35
58	DU10540			40
59	DU10545			45
60	DU10550			50
61	DU10560			60
62	DU10565			65
63	DU11030	110	115	30
64	DU11040			40
65	DU11050			50
66	DU11055			55
67	DU11060			60
68	DU11540	115	120	40
69	DU11545			45
70	DU11560			60
71	DU12045	120	125	45
72	DU12060			60
73	DU12550	125	130	50
74	DU12560			60
75	DU13035	130	135	35
76	DU13040			40
77	DU13050			50
78	DU13060			60



www.hanzl.com.cn