



Low Profile Single-Point

FEATURES

- Capacities: 0.6 to 200 kg
- Small size with low profile
- Anodized aluminum
- NTEP Class III 5000S approval from 3 kg to 30 kg
- OIML C3 approval from 6 kg to 35 kg
- Platform size: 16"x16"/ 40 cm x 40 cm
- **Optional**
 - FM approval available



APPLICATIONS

- Packaging machines
- Dosing/filling
- Belt scales/conveyor scales
- In-motion check weigher
- Retail scales/counting scales



DESCRIPTION

LPS is designed for electronic scales and platform scales where only one load cell can be used and low profile is required. It is the lightest model of Celtron single-point

load cell family. The design is most suitable for mass production operations.

LPS is constructed of anodized aluminum and is fully potted IP66 levels, providing excellent protection against moisture ingress.

OUTLINE DIMENSIONS

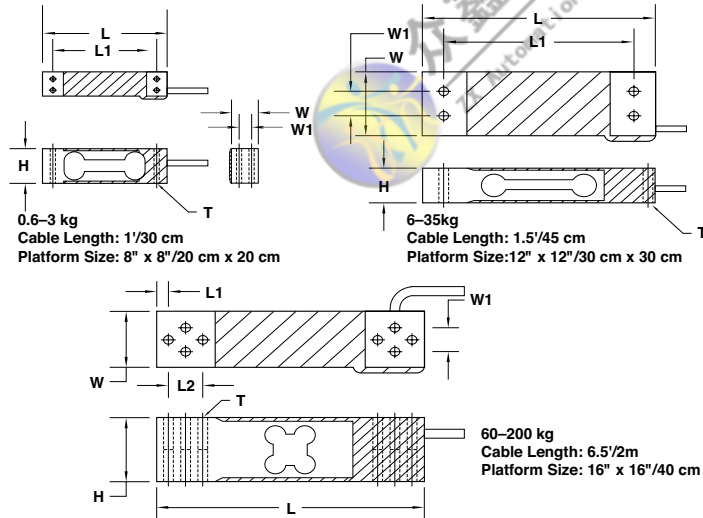

Wiring diagram

- + Excitation Red
- Excitation Black
- + Signal Green
- Signal White

CAPACITY (kg)		L	L ₁	L ₂	W	W ₁	H	T
0.6/1/2/3	mm	70.0	58.0	-	15.0	7.0	22.0	M3 x 0.5
	(inch)	2.76	2.28	-	0.59	0.28	0.87	
6/10/15/20	mm	130.0	106.0	-	30.0	15.0	22.0	M6 x 1.0
	(inch)	5.12	4.17	-	1.18	0.59	0.87	
30/35	mm	130.0	106.0	-	40.0	15.0	22.0	M6 x 1.0
	(inch)	5.12	4.17	-	1.57	0.59	0.87	
60/100/200	mm	150.0	7.0	19.0	35.0	15.0	40.0	M6 x 1.0
	(inch)	5.91	0.28	0.75	1.38	0.59	1.57	



Low Profile Single-Point

SPECIFICATIONS				
PARAMETER	VALUE			UNIT
NTEP/OIML accuracy class	NTEP III	Non-Approved	C3	
Maximum no. of intervals (n)	5000 single ⁽¹⁾	1000	3000 ⁽²⁾	
Y = E _{max} /V _{min}	8000	1400	6000	Maximum available 12000
Standard capacities (E _{max})	0.6, 1, 2, 3, 6, 10, 15, 20, 30, 35, 60, 100, 200			kg
Rated output—R.O.	2.0 ⁽³⁾			mV/V
Rated output tolerance	10			±% of rated output
Zero balance	3			±% of rated output
Non-linearity	0.025	0.030	0.020	±% of rated output
Hysteresis	0.025	0.030	0.020	±% of rated output
Non-repeatability	0.020			±% of rated output
Creep error (20 minutes)	0.030	0.030	0.017	±% of rated output
Zero return (20 minutes)	0.030	0.030	0.017	±% of rated output
Temperature effect on min. dead load output	0.0026	0.0026	0.014	±% of rated output/°C
Temperature effect on sensitivity	0.0015	0.0015	0.008	±% of applied load/°C
Compensated temperature range	-10 to +40			°C
Operating temperature range	-20 to +60			°C
Safe overload	150			% of R.C.
Ultimate overload	200			% of R.C.
Excitation, recommended	10			VDC or VAC RMS
Excitation, maximum	15			VDC or VAC RMS
Input impedance	410±10			Ω
Output impedance	350±3			Ω
Insulation resistance	>5000			MΩ
Construction	Anodized aluminum			
Environmental protection	IP66			

Notes
⁽¹⁾ Capacities 3–30 kg

⁽²⁾ Capacities 6–35 kg

⁽³⁾ 1 mV/V for 1 kg and below

All specifications subject to change without notice.

FM Approval

Intrinsically Safe: Class I, II, III; Div. 1 Groups A-G

Non-Incendive: Class I; Div. 2 Groups A-D



众鑫自动化

专注传感器品质

为多种工业领域提供完整的自动化称重解决方案

联系人：陈经理

QQ：2473329660

TEL：185-2027-1262

网址：www.zhongxintmt.com



Legal Disclaimer Notice
Vishay Precision Group, Inc.

Disclaimer

ALL PRODUCTS, PRODUCT SPECIFICATIONS AND DATA ARE SUBJECT TO CHANGE WITHOUT NOTICE.

Vishay Precision Group, Inc., its affiliates, agents, and employees, and all persons acting on its or their behalf (collectively, "VPG"), disclaim any and all liability for any errors, inaccuracies or incompleteness contained herein or in any other disclosure relating to any product.

The product specifications do not expand or otherwise modify VPG's terms and conditions of purchase, including but not limited to, the warranty expressed therein.

VPG makes no warranty, representation or guarantee other than as set forth in the terms and conditions of purchase.

To the maximum extent permitted by applicable law, VPG disclaims (i) any and all liability arising out of the application or use of any product, (ii) any and all liability, including without limitation special, consequential or incidental damages, and (iii) any and all implied warranties, including warranties of fitness for particular purpose, non-infringement and merchantability.

Information provided in datasheets and/or specifications may vary from actual results in different applications and performance may vary over time. Statements regarding the suitability of products for certain types of applications are based on VPG's knowledge of typical requirements that are often placed on VPG products. It is the customer's responsibility to validate that a particular product with the properties described in the product specification is suitable for use in a particular application. You should ensure you have the current version of the relevant information by contacting VPG prior to performing installation or use of the product, such as on our website at vpgsensors.com.

No license, express, implied, or otherwise, to any intellectual property rights is granted by this document, or by any conduct of VPG.

The products shown herein are not designed for use in life-saving or life-sustaining applications unless otherwise expressly indicated. Customers using or selling VPG products not expressly indicated for use in such applications do so entirely at their own risk and agree to fully indemnify VPG for any damages arising or resulting from such use or sale. Please contact authorized VPG personnel to obtain written terms and conditions regarding products designed for such applications.

Product names and markings noted herein may be trademarks of their respective owners.

Copyright Vishay Precision Group, Inc., 2014. All rights reserved.