

Hand lever presses

Series 5501

Code:	5501 EN
Delivery:	ex stock/2-3 weeks
Warranty:	24 months



- Range of forces 1.5 kN to 30 kN
- Toggle-action or rack-and-pinion version
- Hardened, ground ram
- Direct force measurement by designed-to-fit sensors
- Various mounting options for displacement sensors to suit task in hand

5501 EN

Application

It is easy to equip these manual presses with force and displacement sensors to guarantee comprehensive force-displacement monitoring during assembly, stamping, punching or press-fitting of parts. They are ideal tools for the multi-purpose workstations that are typically used for assembling components in relatively short to medium production runs. The presses themselves – whether rack-and-pinion or toggle-action version – are designed to be multifunctional, with rapid retooling and practically zero maintenance. They offer unrivalled economy and efficiency where production processes and batch sizes vary. With an option for a longer overhang and greater working heights, they can cover an even wider range of potential applications. Thanks to high-precision guidance of the circular ram through the long, honed guide in the press head, the presses are also perfect for assembly processes in precision and instrument engineering.

Description

Used with relevant instrumentation, the press can be regarded as a complete, standalone assembly system. The load cell is fitted in the press as an extension of the ram, and so measures the applied force directly in the press axis. The displacement sensor is mounted on the side of the press head and travels with it, parallel to the ram axis. To handle different component sizes, a leadscrew mechanism provides rapid adjustment of the press head to various working heights on the press pillar. A larger working stroke for the press ram and an extended press-head overhang, depending on the force range, are optionally available. The wide choice of optional extras includes fine adjustment of the working pressure point on toggle presses, and table holes to enable correct positioning of the die. Presses fitted with square rams are also available where particular precision is required in aligning ultra-small parts. These rams also rule out any possible twisting of parts.

Selection of Several Hand Lever Presses with Round Plungers

Model	Compressive Force	Working Stroke [mm]	Overhang A [mm]	Working height B [mm]	Table width by length [mm]	Groove [mm]	Ram bore Ø x depth [mm]	Ram Ø F [mm]	Footprint [mm]	Weight [kg]
5501-6001,5-ZA0000	1.5 kN	40	63	40-235	100 x 65	10	10 ^{H7} x 25	25	110 x 160	8.5
5501-6002,5-ZA0000	2.5 kN	50	80	42-290	157 x 115	12	10 ^{H7} x 25	25	157 x 237	21
5501-6005-KE0000	5 kN	40	63	40-213	100 x 65	10	10 ^{H7} x 25	20	110 x 160	10
5501-6007,5-KE0000	7.5 kN	40	80	58-265	157 x 115	12	10 ^{H7} x 25	24	157 x 237	20
5501-6015-KE0000	15 kN	40	100	49-168	175 x 140	12	10 ^{H7} x 25	30	175 x 300	39
5501-6025-KE0000	25 kN	40	100	60-290	185 x 145	12	10 ^{H7} x 25	30	185 x 300	41

Toggle presses only reach their maximum compressive force at bottom dead center (BDC), which the operator can achieve by exerting a force of just 150 N on the lever. To make it easier to set up the tools, all models are supplied with a height-adjustable press head. The head is moved into the required position by means of a lead-screw in the press pillar and is then bolted in place. The ergonomically designed hand lever has continuous 360° adjustment about its axis. It can be refitted for left-handed use simply by mounting it in on the other side. The circular hardened, ground ram travels in a particularly long, honed guide, guaranteeing practically zero-maintenance operation. The press table has a ground surface and contains a DIN 650 compliant, transverse groove.

Rack-and-pinion presses exert a constant compressive force on the part over the entire stroke length. The force is transmitted directly and with the exact same leverage at every point, allowing fingertip sensitivity whatever the ram position, even when press-fitting longer parts or joining components over relatively long distances. The standard model comes with a mechanically adjustable limit of travel, which stops the downward movement of the ram in the required position. All other technical features relating to adjustment, operation and assembly match the toggle press specifications. The listed options are also available for both types of press.

Options

Anti-twist device

for toggle presses. A pin, running in a groove in the plunger, largely prevents radial twisting.

Model ...-KFxxxx

In addition, toggle presses are also available fitted with a square hardened, ground ram, which guarantees zero-play guidance. This usually dispenses with the need for a guide in the tool, while also ruling out any possibility of twisting during the process.

Table hole

The lower parts of tools can be retained and centered in the central table hole. Fixing is by means of a transverse screw. The table hole also facilitates fast tool changeover, so reducing the setup times.

Model ...-xxAxxx

Fine adjustment of the pressure working point

for toggle presses

Because toggle presses only reach their maximum force at bottom dead center and adjustment by means of a threaded spindle is often too imprecise, the pressure working point can be accurately adjusted directly at the plunger.

Model ...-KGxxxx

The adjustment scale allows the fine setting to be made and read to an accuracy of 0.02 mm; the setting range is ± 1.5 mm.

Greater working height, extended working stroke or extended overhang available

Accessories

In order to fit the displacement sensor securely and firmly on the press head or on the load cell itself while still allowing fine adjustment, assembly kits are available that include all necessary parts such as carriers, plates, screws and mounting diagram for correct positioning

for 8451 load cell, measurement range up to 0 ... 20 kN **5501-Z002**
for 8451 load cell, measurement range starting from 0 ... 50 kN **5501-Z003**

for 8552 load cell **5501-Z004**

Service

Please check with us your options prior to order or dispatch of any heavyweight material. Options may vary according to your country.

Fitting the displacement sensor on the press head for the full ram stroke **55ANB-V001**

Toggle presses: only the final millimeters of the ram stroke **55ANB-V002**

Rack-and-pinion: only the final millimeters of the ram stroke **55ANB-V003**

Technical changes reserved. All data sheets at www.burster.com

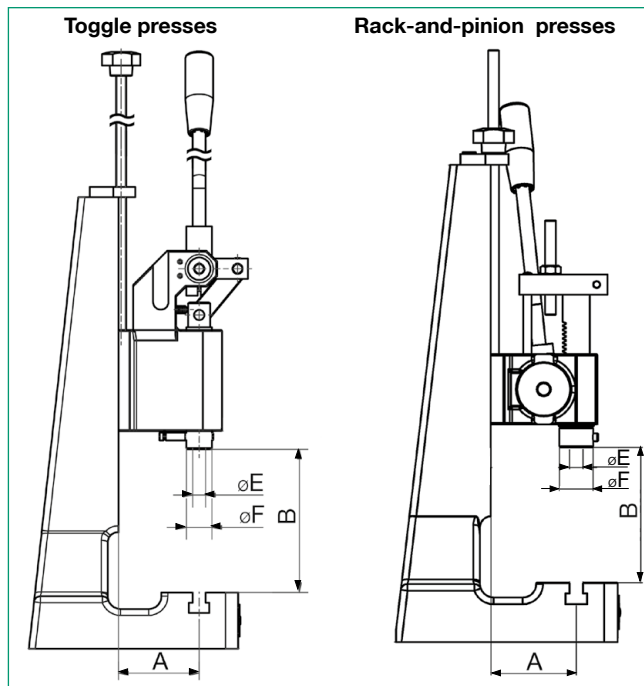

Application example

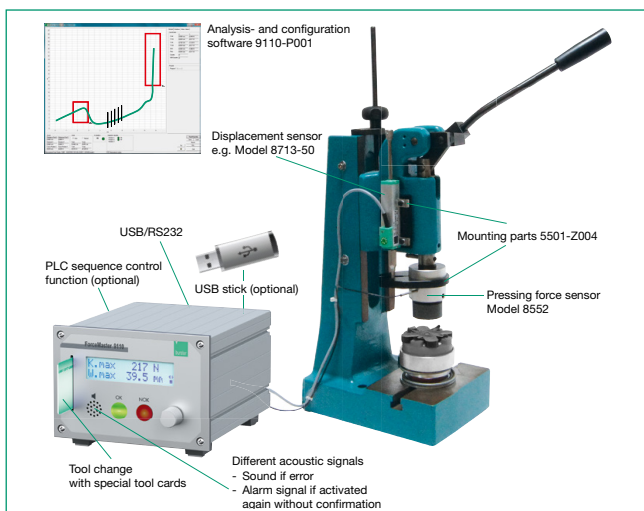

Detailed technical data on the components mentioned in the example application is given in the data sheets for the products concerned.

Presses load cell

Model 8451/8552

Displacement sensor

Model 8712/8713

ForceMaster

Model 9110