

東莞市帝仁精密機電有限公司

Dongguan City Dili Precision Electrical and Mechanical Services Limited

VGM[®] Since 1990

正齒式減速齒輪箱
工業機器人關節齒輪箱

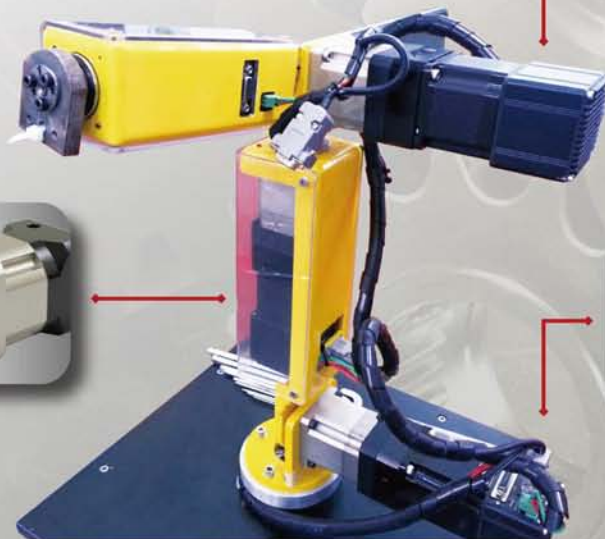

目錄

德国alpha阿尔法行星减速机
德国NEUGART纽卡特行星减速机
德国STOBER斯德博行星减速机
日本HD哈默纳科谐波减速机
日本帝人RV機器人减速机
日本新宝shimpo减速机
日本东方旋转平台
日本住友摆线减速机
韓國SPG行星減速機
韓國SPG旋轉平台
台湾村田RV機器人减速机
台湾柯泰精密大扭矩滚柱减速机
台湾寰宇精密滚柱减速机
台湾精锐广用APEX行星减速机
台湾聚盛VGM行星减速机
台湾品宏科技PHT行星减速机
台湾世协SESAME行星减速机
台湾利明LIMING行星减速机
台湾SG精密行星减速机
台湾CST精密行星减速机
台湾FHT行星减速机
台湾晶贺旋转平台

目錄 Contents



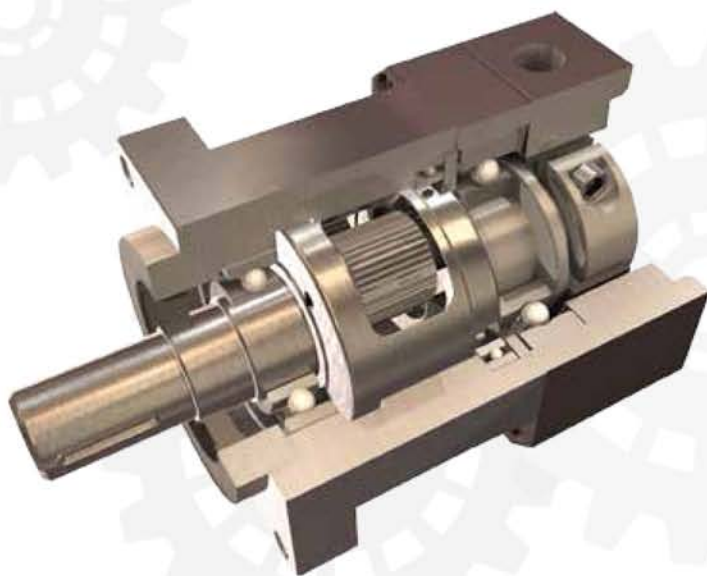

機型代碼：

MF60H

L1

10

M

K

馬達

Model :
MF40H
MF60H
MF90H
MF120H
MF150H
MF180H

段數：
L1：一段比數
L2：二段比數
L3：三段比數

減速比：

i：明細請參考減速比組成表.(P3)

背隙：

M：標準背隙
H：精密背隙

出力軸型式：

K：有鍵槽
S：無鍵槽(光軸)

伺服馬達
廠牌/型號

容許徑向力：垂直於軸心的力量
容許軸向力：平行於軸心的力量

容許徑/軸向力與齒輪箱的出力軸轉速及施力點的距離相關

- a：轉速越快，容許徑向力會降低
- b：負載的距離越遠，容許的徑向力也隨之降低

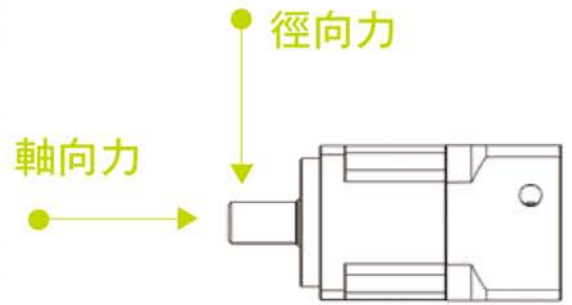

徑向負荷表 (MF-H)

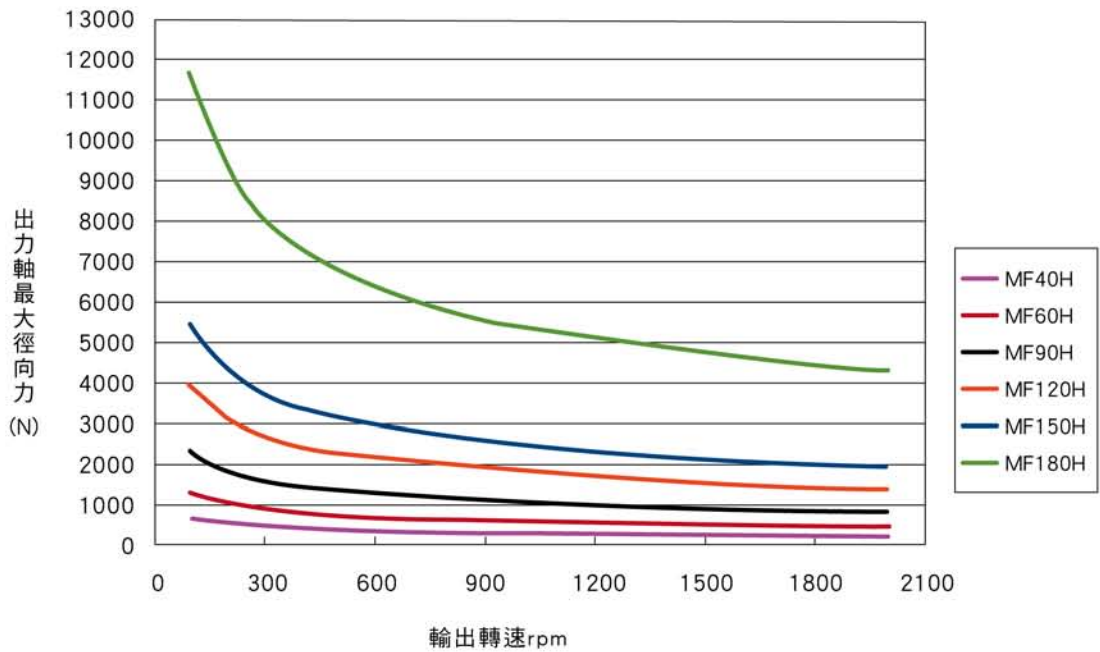

負載係數表 (MF-H)

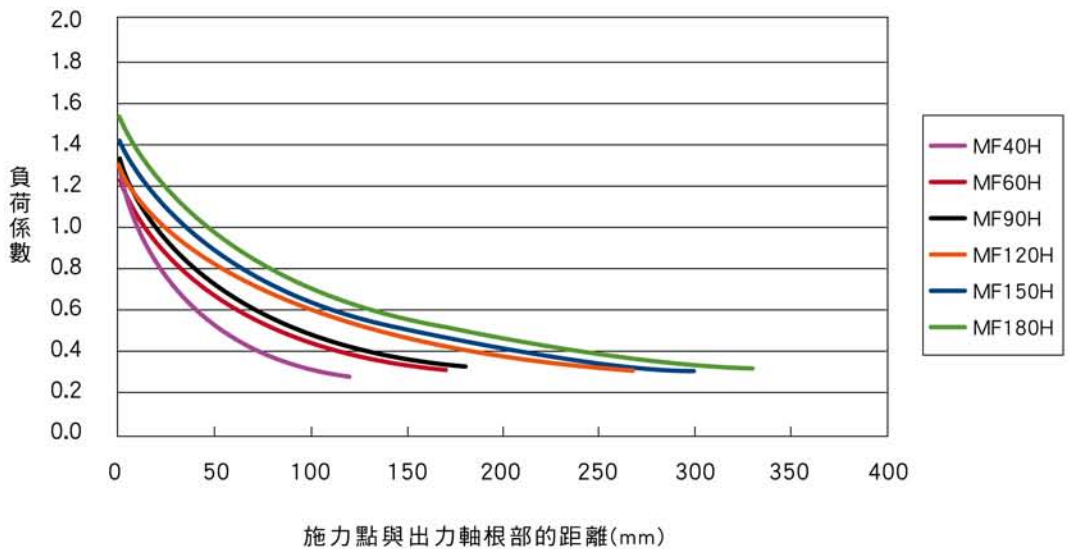

MF-H 齒輪箱選用參考表 (依據伺服馬達輸出功率選擇)																					
		比數																			
馬達功率	齒輪箱型號	1/3	1/4	1/5	1/6	1/7	1/8	1/9	1/10	1/15	1/20	1/25	1/30	1/35	1/40	1/50	1/60	1/70	1/80	1/90	1/100
50W	MF40H	●	●	●	●	●	●		●	●	●	●	●	●	●	●					
100W	MF40H	●	●	●	●	●	●		●												
	MF60H	●	●	●	●	●		●	●	●	●	●	●	●	●	●	●	●		●	●
200W	MF60H	●	●	●	●	●		●	●	●	●	●	●	●	●	●					
	MF90H	●	●	●	●	●	●	●	●	●	●	●	●	●	●	●	●	●	●	●	●
400W	MF60H	●	●	●	●	●		●	●	●	●	●	●	●	●						
	MF90H	●	●	●	●	●	●	●	●	●	●	●	●	●	●	●	●	●	●	●	●
500W	MF90H	●	●	●	●	●	●	●	●	●	●	●	●	●	●	●					
	MF120H	●	●	●	●	●		●	●	●	●	●	●	●	●	●	●	●		●	●
750W	MF90H	●	●	●	●	●	●	●	●	●	●	●	●	●	●	●					
	MF120H	●	●	●	●	●		●	●	●	●	●	●	●	●	●	●				
1KW	MF120H	●	●	●	●	●		●	●	●	●	●	●	●	●	●					
	MF150H	●	●	●	●	●		●	●	●	●	●	●	●	●	●	●	●		●	●
1.5KW	MF120H	●	●	●	●	●		●	●	●	●	●	●	●	●	●					
	MF150H	●	●	●	●	●		●	●	●	●	●	●	●	●	●	●	●			
	MF180H	●	●	●		●			●	●	●	●	●	●	●	●	●	●	●		●
2.0KW	MF150H	●	●	●		●			●	●	●	●	●	●	●	●					
	MF180H	●	●	●		●			●	●	●	●	●	●	●	●	●	●	●		●
3.5KW	MF150H	●	●	●		●			●	●	●	●	●	●	●						
	MF180H	●	●	●		●			●	●	●	●	●	●	●	●	●	●	●		
5.0KW	MF150H	●	●	●		●			●	●	●	●									
	MF180H	●	●	●		●			●	●	●	●	●	●	●	●					
7.0KW	MF150H	●	●	●		●			●												
	MF180H	●	●	●		●			●	●	●										
11.0KW	MF180H	●	●	●		●			●												

備註：

1. 可以依馬達輸出功率選用該比數有'●'記號之齒輪箱型號.
2. 當應用於扭矩或慣性矩較大之場合，必須選用較大一級齒輪箱.
3. 上表未列出之比數，如有需要請洽詢業務工程師.

MF-H 比數組成			
齒輪箱型號	齒輪箱各段可選擇基本齒輪比數		
	一段式比數 (L1)	二段式比數 (L2)	三段式比數 (L3)
MF40H	3, 4, 5, 6, 7, 8, 10	15, 20, 25, 30, 35, 40, 50	
MF60H	3, 4, 5, 6, 7, 9, 10	12, 15, 16, 20, 21, 25, 28, 30, 35, 40, 45, 50, 60, 70, 90, 100	120, 150, 200, 250, 300, 350, 400, 450, 500, 600, 700, 900, 1000
MF90H	3, 4, 5, 6, 7, 8, 9, 10	12, 15, 16, 20, 21, 25, 28, 30, 35, 40, 45, 50, 60, 70, 80, 90, 100	120, 150, 200, 250, 300, 350, 400, 450, 500, 600, 700, 800, 900, 1000
MF120H	3, 4, 5, 6, 7, 8, 9, 10	12, 15, 16, 20, 21, 25, 28, 30, 35, 40, 45, 50, 60, 70, 80, 90, 100	120, 150, 200, 250, 300, 350, 400, 450, 500, 600, 700, 800, 900, 1000
MF150H	3, 4, 5, 7, 10	12, 15, 16, 20, 21, 25, 28, 30, 35, 40, 50, 70, 100	120, 150, 200, 250, 300, 350, 400, 500, 600, 700, 1000
MF180H	3, 4, 5, 6, 7, 10	12, 15, 16, 20, 21, 25, 28, 30, 35, 40, 50, 60, 70, 100	120, 150, 200, 250, 300, 350, 400, 500, 600, 700, 1000

MF-H 技術規格									
規格	單位	段數	比數	MF40H	MF60H	MF90H	MF120H	MF150H	MF180H
額定輸出扭矩 T_{2N}	Nm	L1	3	16	50	125	248	500	1,000
			4	17	43	136	286	580	1,090
			5	17	52	152	320	660	1,215
			6	16	52	145	308	—	1,060
			7	15	46	136	306	540	1,135
			8	13	—	118	240	—	—
			9	—	35	94	225	—	—
			10	13	35	94	225	460	935
			15	13	50	128	210	500	1,000
			20	14	46	142	285	530	1,090
		25	13	58	158	320	660	1,215	
		30	14	52	146	308	610	1,200	
		35	13	48	136	306	540	1,135	
		40	11	43	118	252	530	1,090	
		45	—	36	98	225	—	—	
		50	12	56	156	320	660	1,215	
		60	—	53	148	308	—	1,060	
		70	—	46	135	306	540	1,135	
		80	—	—	116	—	—	—	
		90	—	35	94	225	—	—	
100	—	35	94	225	460	935			
急停扭矩	Nm	L1, L2	3-100	3倍額定輸出扭矩					
額定輸入轉速 n_{1N}	rpm	L1, L2	3-100	3,000	3,000	3,000	2,500	2,500	2,500
最大輸入轉速 n_{1B}	rpm	L1, L2	3-100	6,000	6,000	6,000	5,000	5,000	5,000
精密背隙 H	arcmin	L1	3-10	≤5	≤3	≤3	≤3	≤3	≤3
		L2	15-100	≤8	≤5	≤5	≤5	≤5	≤5
標準背隙 M	arcmin	L1	3-10	≤8	≤5	≤5	≤5	≤5	≤5
		L2	15-100	≤10	≤8	≤8	≤8	≤8	≤8
扭轉剛性	Nm/arcmin	L1, L2	3-100	2.6	7	15	28	51	142
容許徑向力 $F_{r,off}$	N	L1, L2	3-100	750	1,530	3,000	6,200	9,000	14,200
容許軸向力 $F_{a,off}$	N	L1, L2	3-100	375	765	1,500	3,100	4,500	7,100
平均使用壽命	hr	L1, L2	3-100	20,000					
全負載時效率 η	%	L1	3-10	≥98%					
		L2	15-100	≥95%					
淨重	kg	L1	3-10	0.53	1.55	4.37	9.56	17.7	28.75
		L2	15-100	0.7	2	5.52	11.21	22.3	37.8
使用溫度	°C	L1, L2	3-100	-10°C ~ +90°C					
潤滑		L1, L2	3-100	鋰基複合全合成潤滑油脂					
安裝方向		L1, L2	3-100	任意方向					
防護等級		L1, L2	3-100	IP65					
噪音值	dB(A)	L1, L2	3-100	≤65	≤65	≤65	≤68	≤68	≤70

1. 上述單段齒輪箱(未指定比數)相關規格, 主要為使用各型號5比齒輪箱所測得之數據。
2. 減速比: $i = \text{輸入轉速} / \text{輸出轉速}$ 。
3. 背隙值: 為在2%額定輸出扭矩下測試所得之數據。
4. 最大徑向力及最大軸向力: 施力於出力軸中心位置, 週期負載時間50%, 轉速100rpm, 條件下所測得之數據。
5. 運轉負載週期<60%狀況下, 平均使用壽命如列表數據值; 負載週期≥60%之連續運轉狀況下, 平均使用壽命可能會降低至正常值的50%以下。
6. 噪音值: 距離1公尺, 空載運轉, 額定輸入轉速, 條件下所測得之數據。

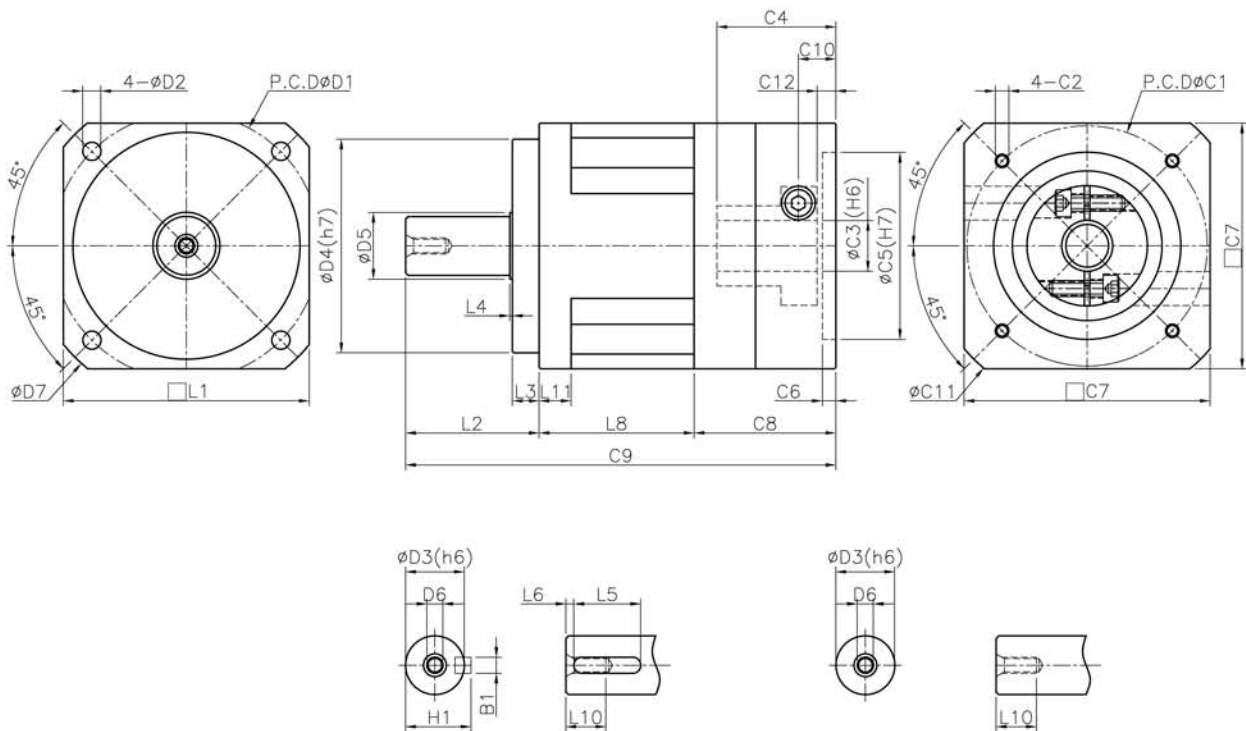

Shaft Option 1(K)

Shaft Option 2(S)

(單位：mm)

尺寸	MF40H-L1	MF60H-L1	MF90H-L1	MF120H-L1	MF150H-L1	MF180H-L1
D1	50	70	100	130	165	215
D2	3.5	5.5	6.8	8.7	11	13
D3	13	16	22	32	38(40)	50(55)
D4	35	50	80	110	130	160
D5	15	18	25	35	40(45)	60
D6	M4×0.7P	M5×0.8P	M6×1.0P	M8×1.25P	M12×1.75P	M12×1.75P(M20×2.5P)
D7	55	80	118	158	190	245
L1	42	60	92	120	142	182
L2	25.5	35.5	50	65	86	105
L3	5.5	7.5	10	12	15	20
L4	0.5	1.5	1	1	3	2
L5	15	20	25	40	45	70
L6	2	3	5	3	5	6
L8	33.5	49	58	69	79	85.5
L10	8	12	15	20	32	42
L11	7	10	12	15	12	15
C1	46	70	90	145	200	200
C2	M4x0.7P(MAX)	M5x0.8P(MAX)	M6x1.0P(MAX)	M8x1.25P(MAX)	M12x1.75P(MAX)	M12x1.75P(MAX)
C3	5-8	6-14	14-19	16-24	19-42	19-42
C4	28	33	39	65	88	85
C5	30	50	70	110	114.3	114.3
C6	4	4	5	7	6	7
C7	42	62	92	120	176	182
C8	34	39.5	49	78	98	100
C9	93	124	157	212	263	290.5
C10	12.5	13	15	28.5	47	33.5
C11	56	80	120	160	230	240
C12	7.5	7	7	20	35	17
B1	4 ^{-0.01} _{-0.03}	5 ^{-0.01} _{-0.03}	6 ^{-0.01} _{-0.03}	10 ^{-0.01} _{-0.03}	10 ^{-0.01} _{-0.03} (12 ^{-0.02} _{-0.04})	14 ^{-0.02} _{-0.06} (16 ^{-0.01} _{-0.04})
H1	14.5	18	24.5	35	41(43)	53.5(59)

1. C1-C6 為公制標準馬達連接板尺寸，尺寸依搭配伺服馬達而改變。
2. C1-C6 為標規品最大max尺寸。如超出尺寸屬特規品。請與我司聯絡。

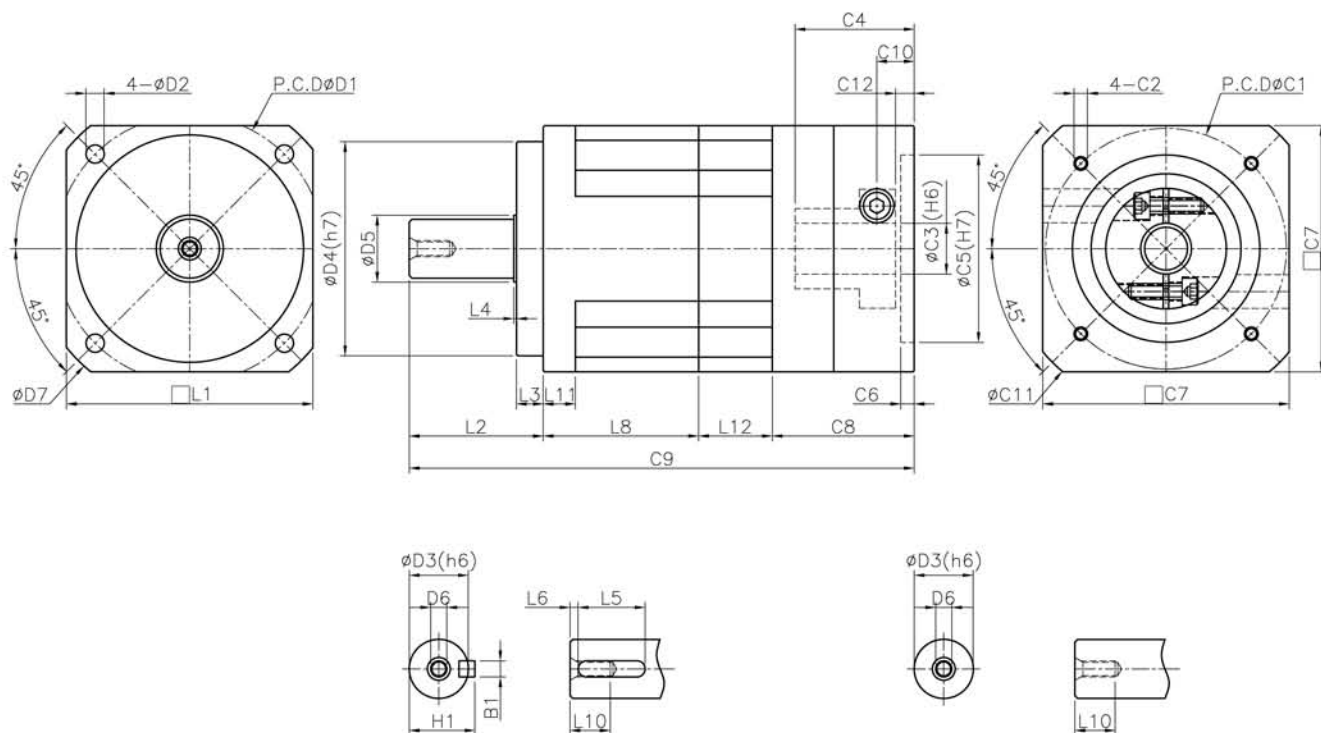

Shaft Option 1(K)

Shaft Option 2(S)

(單位：mm)

尺寸	MF40H-L2	MF60H-L2	MF90H-L2	MF120H-L2	MF150H-L2	MF180H-L2
D1	50	70	100	130	165	215
D2	3.5	5.5	6.8	8.7	11	13
D3	13	16	22	32	38(40)	50(55)
D4	35	50	80	110	130	160
D5	15	18	25	35	40(45)	60
D6	M4×0.7P	M5×0.8P	M6×1.0P	M8×1.25P	M12×1.75P	M12×1.75P(M20×2.5P)
D7	55	80	118	158	190	245
L1	42	60	92	120	142	182
L2	25.5	35.5	50	65	86	105
L3	5.5	7.5	10	12	15	20
L4	0.5	1.5	1	1	3	2
L5	15	20	25	40	45	70
L6	2	3	5	3	5	6
L8	33.5	49	58	69	79	85.5
L10	8	12	15	20	32	42
L11	7	10	12	15	12	15
L12	19	16	27.5	33.2	46	51.5
C1	46	70	90	145	200	200
C2	M4x0.7P(MAX)	M5x0.8P(MAX)	M6x1.0P(MAX)	M8x1.25P(MAX)	M12x1.75P(MAX)	M12x1.75P(MAX)
C3	5-8	6-14	14-19	16-24	19-42	19-42
C4	28	33	39	65	88	85
C5	30	50	70	110	114.3	114.3
C6	4	4	5	7	6	7
C7	42	62	92	120	176	182
C8	34	39.5	49	78	98	100
C9	112	140	184.5	245.2	309	342
C10	12.5	13	15	28.5	47	33.5
C11	56	80	120	160	230	240
C12	7.5	7	7	20	35	17
B1	4 ^{-0.01/-0.03}	5 ^{-0.01/-0.03}	6 ^{-0.01/-0.03}	10 ^{-0.01/-0.03}	10 ^{-0.01/-0.03} (12 ^{-0.02/-0.04})	14 ^{-0.02/-0.06} (16 ^{-0.01/-0.04})
H1	14.5	18	24.5	35	41(43)	53.5(59)

1. C1-C6 為公制標準馬達連接板尺寸，尺寸依搭配伺服馬達而改變。
2. C1-C6 為標規品最大max尺寸。如超出尺寸屬特規品。請與我司聯絡。



MFIX 系列

機型代碼：

MF60X

L1

10

K

馬達

Model :
MF40X
MF60X
MF90X
MF120X
MF150X
MF180X
MF220X

段數：
L1：一段比數
L2：二段比數
L3：三段比數

減速比：

i：明細請參考減速比組成表.(P9)

出力軸型式：
K：有鍵槽
S：無鍵槽(光軸)

伺服馬達
廠牌/型號

容許徑向力：垂直於軸心的力量
容許軸向力：平行於軸心的力量

容許徑/軸向力與減速機的出力軸轉速及施力點的距離相關

- a：轉速越快，容許徑向力會降低
- b：負載的距離越遠，容許的徑向力也隨之降低

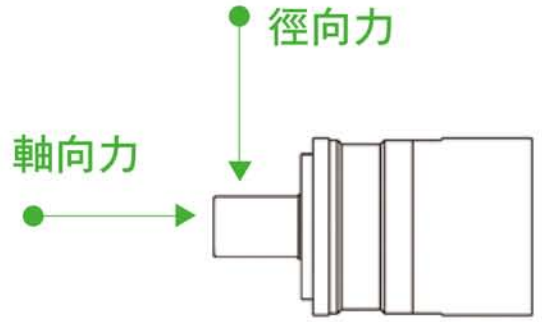

徑向負荷表 (MF-X)

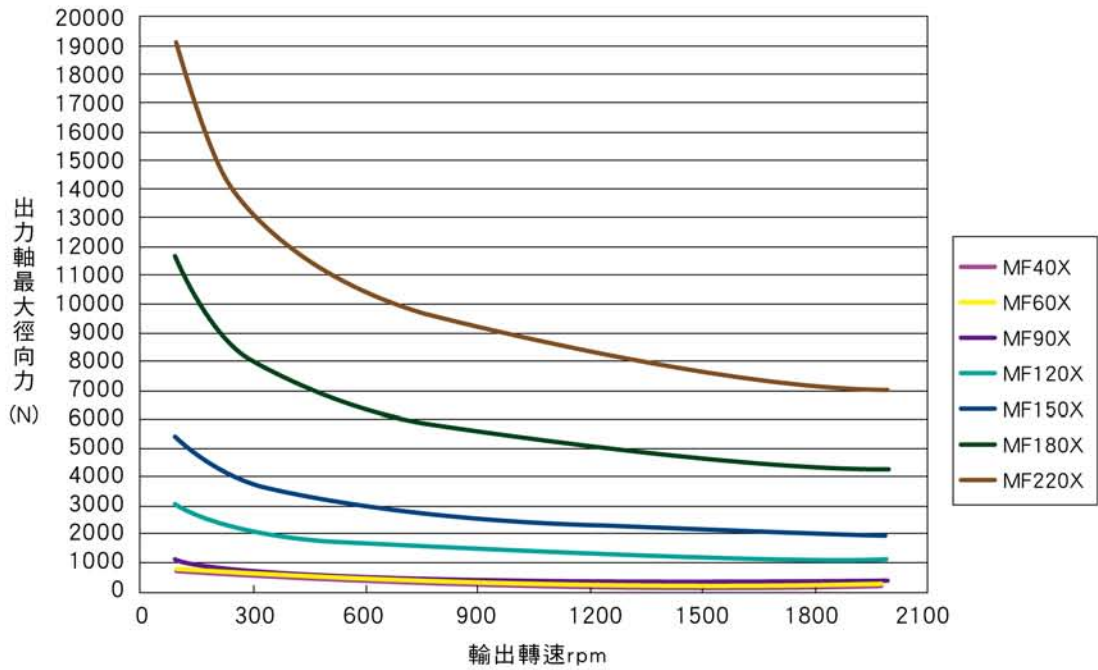

負載係數表 (MF-X)

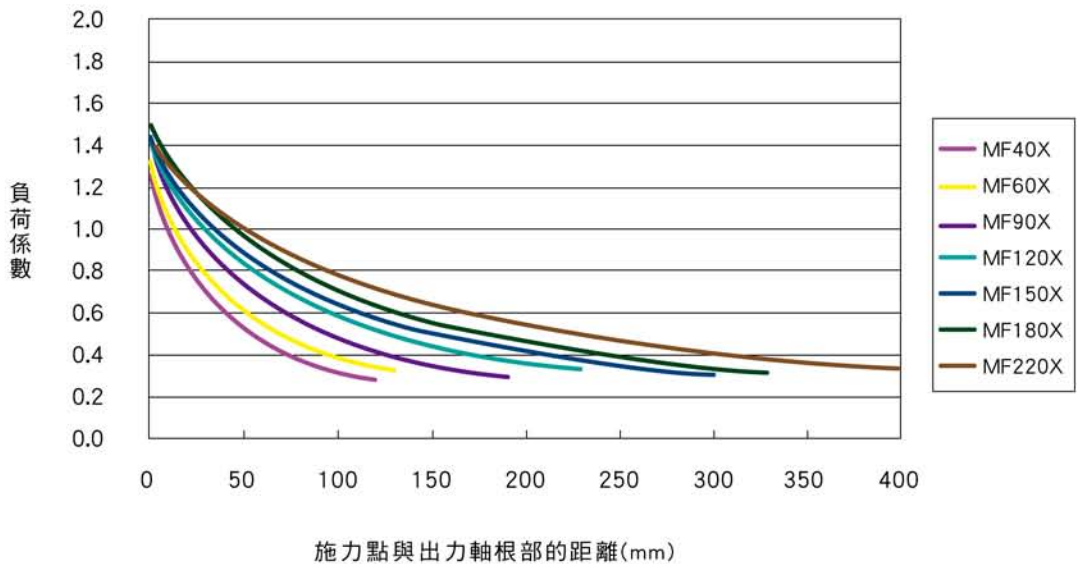

MF-X 齒輪箱選用參考表 (依據伺服馬達輸出功率選擇)		比數																	
馬達功率	齒輪箱型號	1/3	1/4	1/5	1/6	1/7	1/8	1/10	1/15	1/20	1/25	1/30	1/35	1/40	1/50	1/60	1/70	1/100	
50W	MF40X	●	●	●	●	●	●	●	●	●	●	●	●	●	●				
100W	MF40X	●	●	●	●	●	●	●	●	●	●	●	●	●	●				
	MF60X	●	●	●		●		●	●	●	●	●	●	●	●		●	●	
200W	MF60X	●	●	●		●		●	●	●	●	●	●	●	●				
	MF90X	●	●	●		●		●	●	●	●	●	●	●	●		●	●	
400W	MF60X	●	●	●		●		●	●	●	●	●	●	●	●				
	MF90X	●	●	●		●		●	●	●	●	●	●	●	●		●		
500W	MF90X	●	●	●		●		●	●	●	●	●	●	●	●				
	MF120X	●	●	●		●		●	●	●	●	●	●	●	●		●	●	
750W	MF90X	●	●	●		●		●	●	●	●	●	●	●	●				
	MF120X	●	●	●		●		●	●	●	●	●	●	●	●				
1.0KW	MF120X	●	●	●		●		●	●	●	●	●	●	●	●				
	MF150X	●	●	●	●	●		●	●	●	●	●	●	●	●	●	●	●	
1.5KW	MF120X	●	●	●		●		●	●	●	●	●	●	●	●				
	MF150X	●	●	●	●	●		●	●	●	●	●	●	●	●	●			
2.0KW	MF150X	●	●	●	●	●		●	●	●	●	●	●	●	●				
	MF180X	●	●	●		●		●	●	●	●	●	●	●	●		●	●	
3.5KW	MF150X	●	●	●	●	●		●	●	●	●	●	●	●	●				
	MF180X	●	●	●		●		●	●	●	●	●	●	●	●				
5.0KW	MF150X	●	●	●	●	●		●	●	●	●	●	●	●	●				
	MF180X	●	●	●		●		●	●	●	●	●	●	●	●				
7.0KW	MF180X	●	●	●		●		●	●	●	●	●	●	●	●				
	MF220X		●	●		●		●	●	●	●	●	●	●	●				
11.0KW	MF180X	●	●	●		●		●	●	●	●	●	●	●	●				
	MF220X		●	●		●		●	●	●	●	●	●	●	●				
12.0KW	MF220X		●	●		●		●	●	●	●	●	●	●	●				
15.0KW	MF220X		●	●		●		●	●	●	●	●	●	●	●				

MF-X 系列

備註：

1. 可以依馬達輸出功率選用該比數有'●'記號之齒輪箱型號.
2. 當應用於扭矩或慣性矩較大之場合，必須選用較大一級齒輪箱.
3. 上表未列出之比數，如有需要請洽詢業務工程師.

MF-X 比數組成			
齒輪箱型號	齒輪箱各段可選擇基本齒輪比數		
	一段式比數 (L1)	二段式比數 (L2)	三段式比數 (L3)
MF40X	3, 4, 5, 6, 7, 8, 10	15, 20, 25, 30, 35, 40, 50	
MF60X	3, 4, 5, 7, 10	12, 15, 16, 20, 21, 25, 28, 30, 35, 40, 50, 70, 100	120, 150, 200, 250, 300, 350, 400, 500, 700, 1000
MF90X	3, 4, 5, 7, 10	12, 15, 16, 20, 21, 25, 28, 30, 35, 40, 50, 70, 100	120, 150, 200, 250, 300, 350, 400, 500, 700, 1000
MF120X	3, 4, 5, 7, 10	12, 15, 16, 20, 21, 25, 28, 30, 35, 40, 50, 70, 100	120, 150, 200, 250, 300, 350, 400, 500, 700, 1000
MF150X	3, 4, 5, 6, 7, 10	12, 15, 16, 20, 21, 25, 28, 30, 35, 40, 50, 60, 70, 100	120, 150, 200, 250, 300, 350, 400, 500, 700, 1000
MF180X	3, 4, 5, 6, 7, 10	12, 15, 16, 20, 21, 25, 28, 30, 35, 40, 50, 60, 70, 100	120, 150, 200, 250, 300, 350, 400, 500, 700, 1000
MF220X	4, 5, 7, 10	16, 20, 25, 28, 35, 40, 50, 70, 100	

MF-X 技術規格											
規格	單位	段數	比數	MF40X	MF60X	MF90X	MF120X	MF150X	MF180X	MF220X	
額定輸出扭矩 T_{2N}	Nm	L1	3	16	50	125	235	500	1,000	—	
			4	17	35	136	225	580	1,090	1,530	
			5	17	42	152	256	660	1,215	1,900	
			6	16	—	—	—	610	1,060	—	
			7	15	46	136	306	540	1,135	1,620	
			8	13	—	—	—	—	—	—	
		L2	10	13	25	94	225	460	935	1,500	—
			15	13	35	125	210	500	1,000	—	
			20	14	35	142	285	530	1,090	1,530	
			25	13	42	158	320	660	1,215	1,900	
			30	14	42	146	308	610	1,200	—	
			35	13	42	136	306	540	1,135	1,620	
			40	11	25	118	252	530	1,090	1,530	
			45	—	—	—	—	—	—	—	
			50	12	25	156	320	660	1,215	1,500	
			60	—	—	—	—	610	1,060	—	
			70	—	46	135	306	540	1,135	1,620	
			80	—	—	—	—	—	—	—	
			90	—	—	—	—	—	—	—	
100	—	25	94	225	460	935	1,500				
急停扭矩	Nm	L1, L2	3-100	3倍額定輸出扭矩							
額定輸入轉速 n_{1N}	rpm	L1, L2	3-100	3,000	3,000	3,000	2,500	2,500	2,500	2,000	
最大輸入轉速 n_{1B}	rpm	L1, L2	3-100	6,000	6,000	6,000	5,000	5,000	5,000	4,000	
標準背隙	arcmin	L1	3-10	≤10	≤10	≤8	≤8	≤6	≤6	≤6	
		L2	15-100	≤15	≤15	≤12	≤12	≤10	≤10	≤10	
扭轉剛性	Nm/arcmin	L1, L2	3-100	3	6	12	25	51	142	215	
容許徑向力 F_{oB}	N	L1, L2	3-100	750	1,200	2,500	5,600	9,000	14,200	48,000	
容許軸向力 F_{rB}	N	L1, L2	3-100	375	600	1,250	2,800	4,500	7,100	24,000	
平均使用壽命	hr	L1, L2	3-100	20,000							
全負載時效率 η	%	L1	3-10	≥98%							
		L2	15-100	≥95%							
淨重	kg	L1	3-10	0.5	1.05	2.9	7.46	15.1	26	50.3	
		L2	15-100	0.69	1.34	3.75	9.44	18.9	34.33	66.1	
使用溫度	°C	L1, L2	3-100	-10°C ~ +90°C							
潤滑		L1, L2	3-100	鋰基複合全合成潤滑油脂							
安裝方向		L1, L2	3-100	任意方向							
防護等級		L1, L2	3-100	IP65							
噪音值	dBA	L1, L2	3-100	≤65	≤65	≤65	≤68	≤68	≤70	≤72	

1. 上述單段齒輪箱(未指定比數)相關規格，主要為使用各型號5比齒輪箱所測得之數據。
2. 減速比： $i = \text{輸入轉速} / \text{輸出轉速}$ 。
3. 背隙值：為在2%額定輸出扭矩下測試所得之數據。
4. 最大徑向力及最大軸向力：施力於出力軸中心位置，週期負載時間50%，轉速100rpm，條件下所測得之數據。
5. 運轉負載週期<60%狀況下，平均使用壽命如列表數據值；負載週期≥60%之連續運轉狀況下，平均使用壽命可能會降低至正常值的50%以下。
6. 噪音值：距離1公尺，空載運轉，額定輸入轉速，條件下所測得之數據。

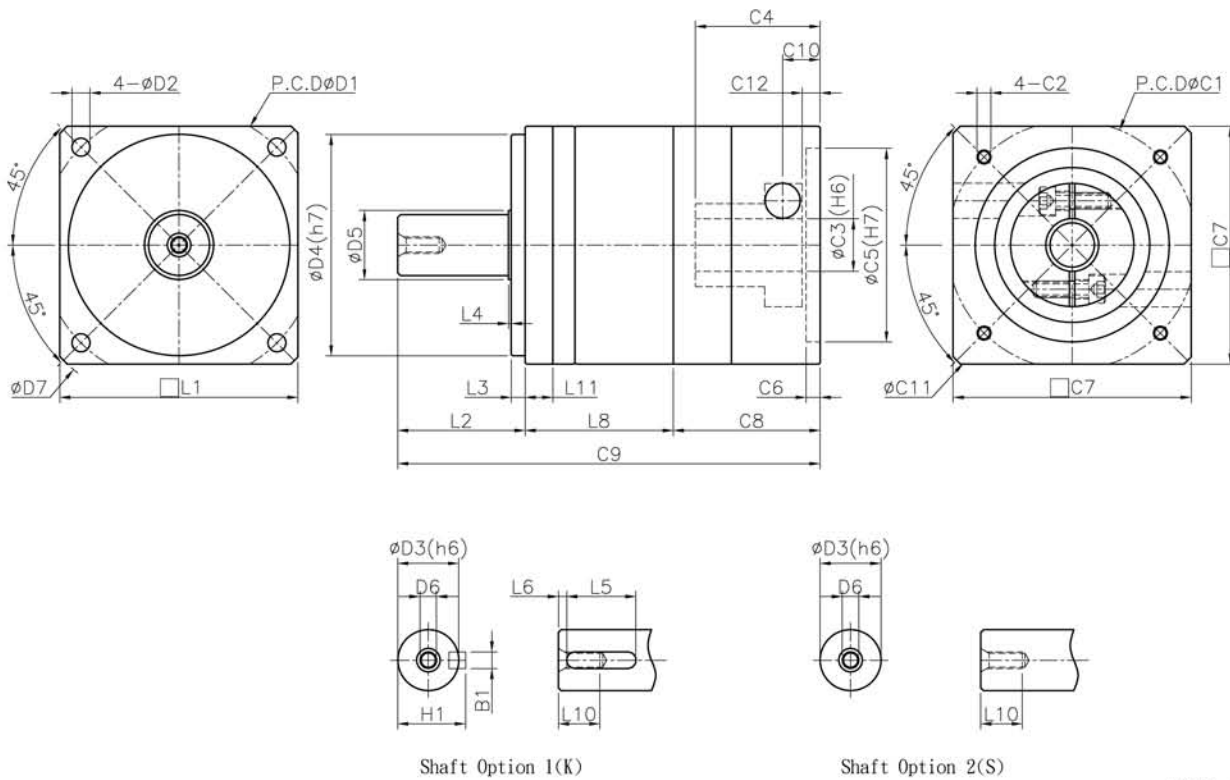

(單位：mm)

尺寸	MF40X-L1	MF60X-L1	MF90X-L1	MF120X-L1	MF150X-L1	MF180X-L1	MF220X-L1
D1	50	70	100	145(130)	165	215	250
D2	3.5	5.5	6.5	8.8	11	13	17
D3	13	16	22	32	38(40)	50(55)	75
D4	35	50	80	110	130	160	180
D5	15	17	25	35	40(45)	60	80
D6	M4×0.7P	M5×0.8P	M6×1.0P	M8×1.25P	M12×1.75P	M12×1.75P(M20×2.5P)	M20×2.5P
D7	60	80	118	160	190	245	292
L1	46	62	86	120	142	182	220
L2	26	33	46	69.5	75	95	123
L3	5.5	5	5	10	4	10	15
L4	1	1.5	1	0.5	3	2	3
L5	15	20	25	40	45	70	90
L6	2	3	3	3	5	6	7
L8	33	43	53.5	70.5	90	95.5	123.5
L10	8	12	15	20	32	42	52
L11	9.5	10	10	15	15	15	20
C1	46	70	90	145	200	200	235
C2	M4×0.7P(MAX)	M5×0.8P(MAX)	M8×1.0P(MAX)	M8×1.25P(MAX)	M12×1.75P(MAX)	M12×1.75P(MAX)	M12×1.75P(MAX)
C3	5-8	6-14	14-19	16-24	19-42	19-42	35-55
C4	26	31	41	66	88	85	128
C5	30	50	70	110	114.3	114.3	200
C6	4	3.5	5	7	6	7	10
C7	46	62	86	120	176	182	220
C8	32.5	37	49.5	77	98	100	148
C9	91.5	113	149	217	263	290.5	394.5
C10	11	12	15	28.5	47	33.5	44
C11	60	80	118	160	240	240	292
C12	6	6	7	20	35	17	27.5
B1	4 ^{-0.01/-0.03}	5 ^{-0.01/-0.03}	6 ^{-0.01/-0.03}	10 ^{-0.02/-0.05}	10 ^{-0.01/-0.03} (12 ^{-0.02/-0.04})	14 ^{-0.02/-0.06} (16 ^{-0.01/-0.04})	20 ^{-0.02/-0.07}
H1	14.5	18	24.5	35	41(43)	53.5(59)	79.5

1. C1-C6 為公制標準馬達連接板尺寸，尺寸依搭配伺服馬達而改變。
2. C1-C6 為標規品最大max尺寸。如超出尺寸屬特規品。請與我司聯絡。

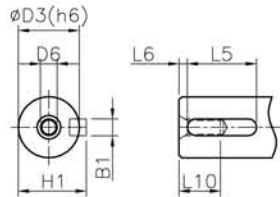
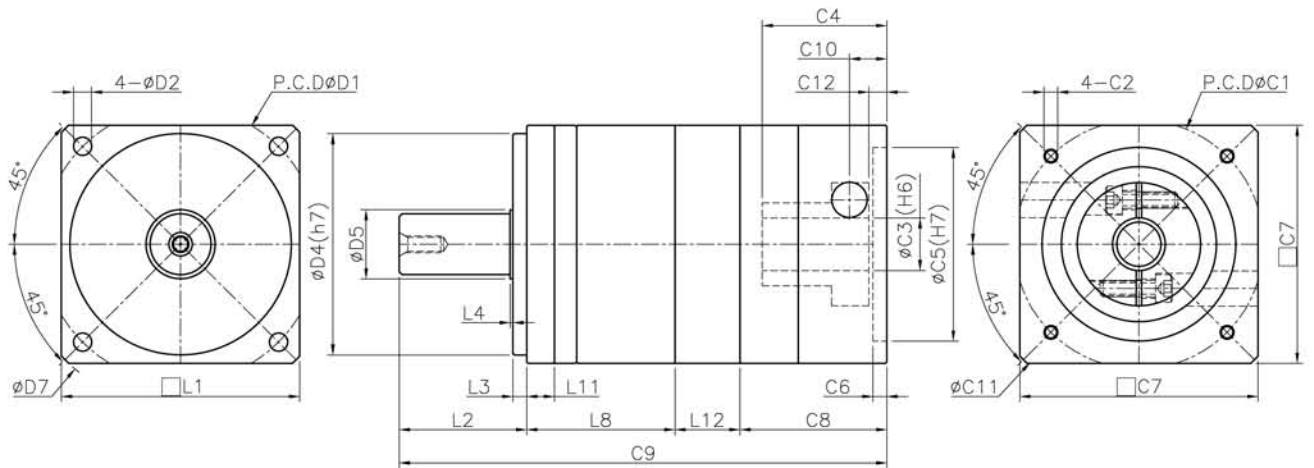

Shaft Option 1(K)

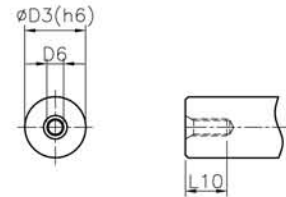

Shaft Option 2(S)

(單位：mm)

尺寸	MF40X-L2	MF60X-L2	MF90X-L2	MF120X-L2	MF150X-L2	MF180X-L2	MF220X-L2
D1	50	70	100	145(130)	165	215	250
D2	3.5	5.5	6.5	8.8	11	13	17
D3	13	16	22	32	38(40)	50(55)	75
D4	35	50	80	110	130	160	180
D5	15	17	25	35	40(45)	60	80
D6	M4×0.7P	M5×0.8P	M6×1.0P	M8×1.25P	M12×1.75P	M12×1.75P(M20X2.5P)	M20×2.5P
D7	60	80	118	160	190	245	292
L1	46	62	86	120	142	182	220
L2	26	33	46	69.5	75	95	123
L3	5.5	5	5	10	4	10	15
L4	1	1.5	1	0.5	3	2	3
L5	15	20	25	40	45	70	90
L6	2	3	3	3	5	6	7
L8	33	43	53.5	70.5	90	95.5	123.5
L10	8	12	15	20	32	42	52
L11	9.5	10	10	15	15	15	20
L12	19	16	23.5	27.2	46	51.5	56.5
C1	46	70	90	145	200	200	235
C2	M4x0.7P(MAX)	M5x0.8P(MAX)	M6x1.0P(MAX)	M8x1.25P(MAX)	M8x1.75P(MAX)	M12x1.75P(MAX)	M12x1.75P(MAX)
C3	5-8	6-14	14-19	16-24	19-42	19-42	35-55
C4	26	31	41	66	88	85	128
C5	30	50	70	110	114.3	114.3	200
C6	4	3.5	5	7	6	7	10
C7	46	62	86	120	176	182	220
C8	32.5	37	49.5	77	98	100	148
C9	110.5	129	172.5	244.2	309	342	451
C10	11	12	15	28.5	47	33.5	44
C11	60	80	118	160	240	240	292
C12	6	6	7	20	35	17	27.5
B1	4 ^{-0.01} / _{-0.03}	5 ^{-0.01} / _{-0.03}	6 ^{-0.01} / _{-0.03}	10 ^{-0.02} / _{-0.05}	10 ^{-0.01} / _{-0.03} (12 ^{-0.02} / _{-0.04})	14 ^{-0.02} / _{-0.06} (16 ^{-0.01} / _{-0.04})	20 ^{-0.02} / _{-0.07}
H1	14.5	18	24.5	35	41(43)	53.5(59)	79.5

1. C1-C6 為公制標準馬達連接板尺寸，尺寸依搭配伺服馬達而改變。
2. C1-C6 為標規品最大max尺寸，如超出尺寸屬特規品，請與我司聯絡。

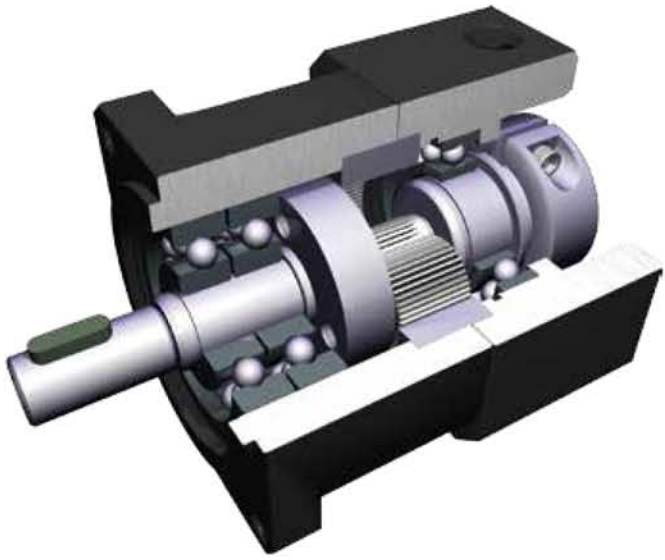

機型代碼：

MF070S — L1 — 10 — 馬達

Model :
MF070S
MF090S
MF120S
MF150S
MF180S

段數：

- L1：一段比數
- L2：二段比數
- L3：三段比數

伺服馬達
廠牌/型號

減速比：

i：明細請參考減速比組成表.(P15)

M
F
|
S
系列

徑向負荷表 (MF-S)

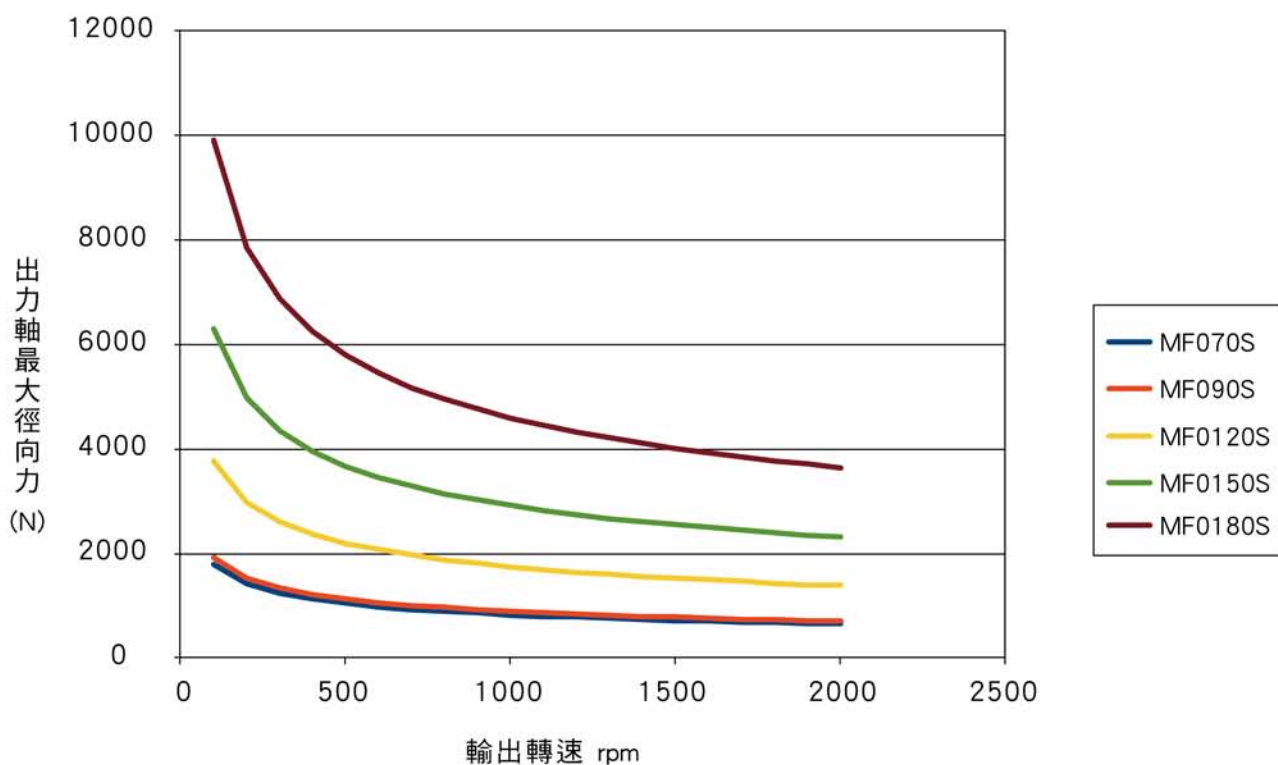

負載係數表 (MF-S)

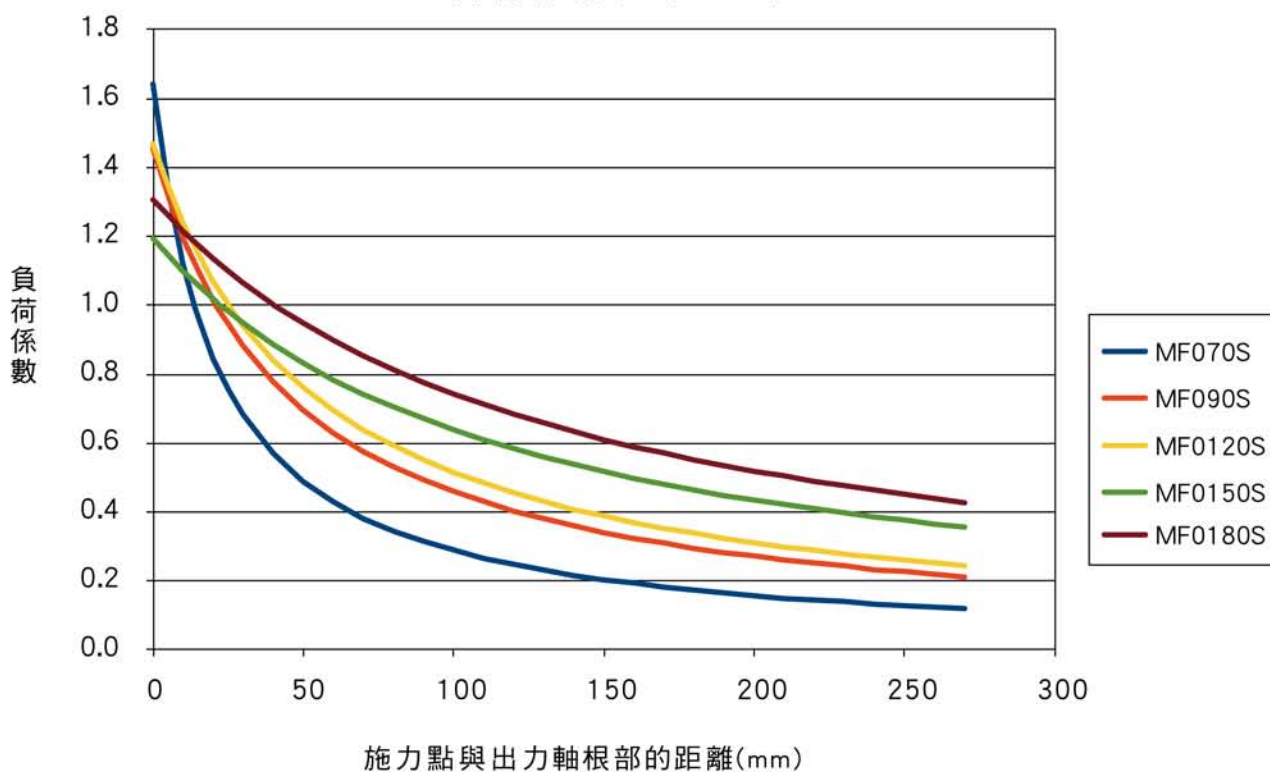

MF/S 齒輪箱選用參考表(依據伺服馬達輸出功率選擇)

馬達功率	齒輪箱型號	比數																			
		1/3	1/4	1/5	1/7	1/9	1/10	1/12	1/15	1/16	1/20	1/21	1/25	1/28	1/30	1/35	1/40	1/49	1/50	1/70	1/100
400W	MF070S	●	●	●	●	●		●	●	●	●	●	●	●	●						
	MF090S	●	●	●	●	●		●	●	●	●	●	●	●	●	●		●			
500W	MF090S	●	●	●	●	●		●	●	●	●	●	●	●	●	●					
	MF120S	●	●	●	●	●		●	●	●	●	●	●	●	●	●		●			●
750W	MF090S	●	●	●	●	●		●	●	●	●	●	●	●	●	●					
	MF120S	●	●	●	●	●		●	●	●	●	●	●	●	●	●		●			
1KW	MF120S	●	●	●	●	●		●	●	●	●	●	●	●	●	●		●			
	MF150S	●	●	●	●	●	●	●	●	●	●	●	●	●	●	●	●	●	●	●	●
1.5KW	MF120S	●	●	●	●	●		●	●	●	●	●	●	●	●	●					
	MF150S	●	●	●	●	●	●	●	●	●	●	●	●	●	●	●	●	●	●	●	●
2.0KW	MF150S	●	●	●	●	●		●	●	●	●	●	●	●	●	●	●	●	●	●	●
	MF180S	●		●	●	●	●	●	●	●	●	●	●	●	●	●	●	●	●	●	●
3.5KW	MF150S	●	●	●	●	●		●	●	●	●	●	●	●	●	●					
	MF180S	●		●	●	●	●	●	●	●	●	●	●	●	●	●	●	●	●	●	●
5.0KW	MF150S	●	●	●	●	●		●	●	●	●	●	●	●	●	●					
	MF180S	●		●	●	●	●	●	●	●	●	●	●	●	●	●	●	●	●	●	●
7.0KW	MF180S	●		●	●	●	●	●	●	●	●	●	●	●	●	●	●	●	●	●	●

備註：

1. 可以依馬達輸出功率選用該比數有'●'記號之齒輪箱型號.
2. 當應用於扭矩或慣性矩較大之場合，必須選用較大一級齒輪箱.
3. 上表未列出之比數，如有需要請洽詢業務工程師.

MF-S 比數選擇

齒輪箱型號	比數		
	一段式比數 (L1)	二段式比數 (L2)	三段式比數 (L3)
MF70S	3.4.5.7	9, 12, 15, 16, 20, 21, 25, 28, 35, 49	27, 36, 45, 48, 60, 75, 80, 100
MF90S	3.4.5.7	9, 12, 15, 16, 20, 21, 25, 28, 35, 49	27, 36, 45, 48, 60, 75, 80, 100
MF120S	3.4.5.7	9, 12, 15, 16, 20, 21, 25, 28, 35, 49	27, 36, 45, 48, 60, 75, 80, 100
MF150S	3, 4, 5, 7, 10	9, 12, 15, 16, 20, 21, 25, 28, 30, 35, 40, 49, 50, 70	27, 36, 45, 48, 60, 75, 80, 90, 100
MF180S	3, 5, 7, 10	9, 12, 15, 20, 21, 25, 28, 30, 35, 40, 49, 50, 70, 100	27, 36, 45, 48, 60, 75, 80, 90

直接選用上表中齒輪箱不同段數之比數

MF-S 技術規格								
規格	單位	段數	比數	MF070S	MF090S	MF120S	MF150S	MF180S
額定輸出扭矩	Nm	L1	3	25	80	190	450	1,050
			4	34	90	230	520	1,120
			5	30	86	220	500	1,100
			7	25	82	200	480	1,080
			10	—	—	—	450	1,050
		L2	9	25	80	200	480	1,080
			15	25	80	200	480	1,080
			20	34	90	230	520	1,120
			25	30	86	220	500	1,100
			35	30	86	220	500	1,100
			40	—	—	—	450	1,120
			49	25	80	200	480	1,080
		L3	70	—	—	—	450	1,080
			100	—	—	—	—	1,050
			27	34	90	230	520	1,120
			36	25	80	200	480	1,080
			45	25	80	200	480	1,080
			48	25	80	200	480	1,080
60	25	80	200	480	1,080			
75	25	80	200	480	1,080			
80	34	90	230	520	1,120			
100	34	90	230	500	—			
急停扭矩	Nm	L1, L2, L3	3-100	2.5倍額定輸出扭矩				
額定輸入轉速	rpm	L1, L2, L3	3-100	3,000	3,000	2,000	2,000	2,000
最大輸入轉速	rpm	L1, L2, L3	3-100	4,500	4,500	3,000	3,000	3,000
標準背隙	arcmin	L1	3-10	≤10-15	≤10-15	≤10-15	≤8-12	≤6-10
		L2	9-100	≤13-18	≤13-18	≤13-18	≤10-14	≤10-14
扭轉剛性	Nm/arcmin	L1, L2, L3	3-100	4	13	35	64	135
容許徑向力	N	L1, L2, L3	3-100	1,790	1,920	3,770	6,290	9,910
容許軸向力	N	L1, L2, L3	3-100	930	1,010	2,075	3,210	5,800
平均使用壽命	hr	L1, L2, L3	3-100	20,000				
全負載時效率	%	L1	3-10	≥ 96%				
		L2	9-100	≥ 93%				
		L3	27-100	≥ 90%				
淨重	kg	L1	3-10	1.5	3.3	6.0	15.2	37.0
		L2	9-100	1.9	4.2	7.2	16.2	46.4
		L3	27-100	2.2	6.8	8.2	18.5	
使用溫度	°C	L1, L2, L3	3-100	- 10°C ~ + 90°C				
潤滑		L1, L2, L3	3-100	全合成潤滑油脂				
安裝方向		L1, L2, L3	3-100	任意方向				
噪音值	dBA	L1, L2, L3	3-100	≤70	≤70	≤70	≤74	≤74

1. 上述單段齒輪箱(未指定比數)相關規格，主要為使用各型號5比齒輪箱所測得之數據。
2. 減速比： $i = \text{輸入轉速}/\text{輸出轉速}$ 。
3. 背隙值：為在2%額定輸出扭矩下測試所得之數據。
4. 最大徑向力及最大軸向力：施力於出力軸中心位置，週期負載時間50%，轉速100rpm，條件下所測得之數據。
5. 運轉負載週期<60%狀況下，平均使用壽命如列表數據值；負載週期≥60%之連續運轉狀況下，平均使用壽命可能會降低至正常值的50%以下。
6. 噪音值：距離1公尺，空載運轉，額定輸入轉速，條件下所測得之數據。

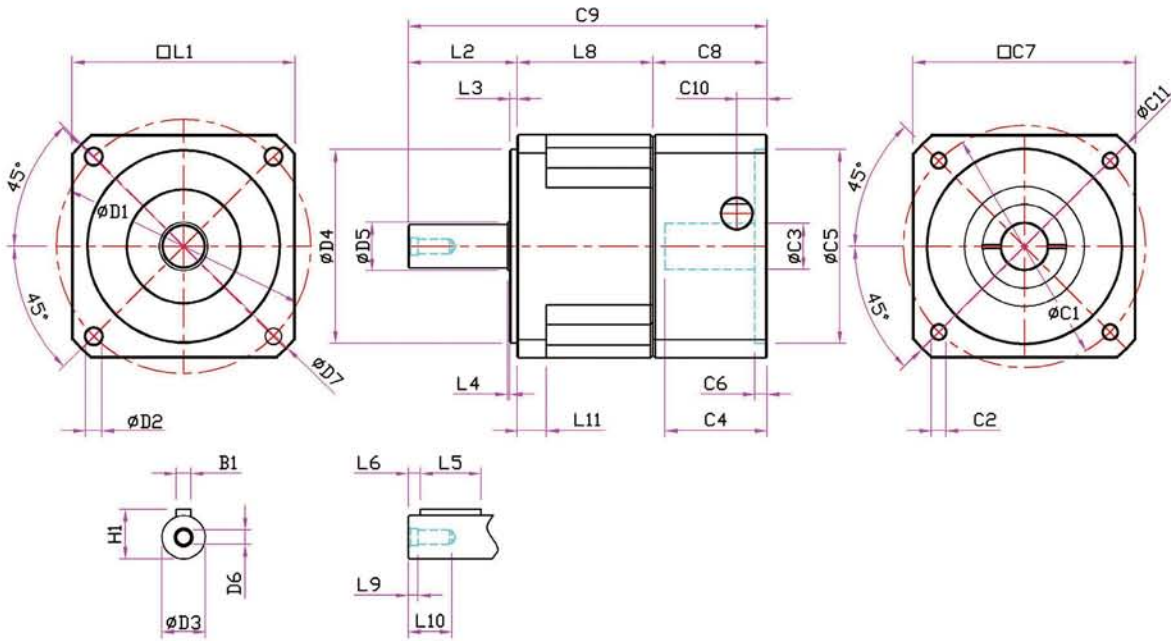

(單位：mm)

尺寸	MF070S	MF090S	MF120S	MF150S	MF180S
D1	75	105	130	165	215
D2	5.5	6.8	8.7	10.5	13
D3	14	18	24	38(40)	50
D4	60	80	110	130	160
D5	15	20	35	40	60
D6	M5×0.8P	M6×1P	M8×1.25P	M12×1.75P	M12×1.75P
D7	90	120	150	190	240
L1	70	92	115	142	182
L2	32.5	45	56	75.5	95
L3	3	3	3.5	4.5	10
L4	1	1	1	3	2
L5	20	25	40	45	70
L6	2	5	5	5	6
L8	一段	49.6	56	62.1	103.1
	二段	72	84	90.1	138.6
	三段	93.8	112	118.1	174
L9	3	4	4	8	10
L10	14	18	20	32	34
L11	10	12	13.6	18.4	26
C1	70	100	100	165	200
C2	M5×0.8P(MAX)	M6×1P(MAX)	M8×1.25P(MAX)	M10×1.5P(MAX)	M12×1.75P(MAX)
C3	6.35-14	14-19	16-24	22-42	35-42
C4	32.5	42.1	47.4	69.5	82.5
C5	50	80	80	130	114.3
C6	4	5	5	15	11
C7	70	92	115	142	182
C8	47.5	47.1	52	86.9	110
C9	一段	129.6	148.1	170.1	265.5
	二段	152	176.1	198.1	300.5
	三段	173.8	204.1	226.1	336.4
C10	12	12.5	14.5	27	30
C11	90	120	150	190	240
B1	5	6	8	10(12)	14
H1	16	20.5	27	41	53.5

1. C1-C6 為公制標準馬達連接板尺寸，尺寸依搭配伺服馬達而改變。
2. C1-C6 為標規品最大max尺寸。如超出尺寸屬特規品。請與我司聯絡。

PF/PX



PG



機型代碼：

P 系列

L1

10

馬達

Model :
PG60
PG90
PG120

Model :
PF60
PF90
PF120

Model :
PX60
PX90
PX120

伺服馬達
廠牌/型號

段數：

L1：一段比數
L2：二段比數
L3：三段比數

減速比：

i：明細請參考減速比選用表.(P20)

徑向負荷表 (PG/PF/PX)

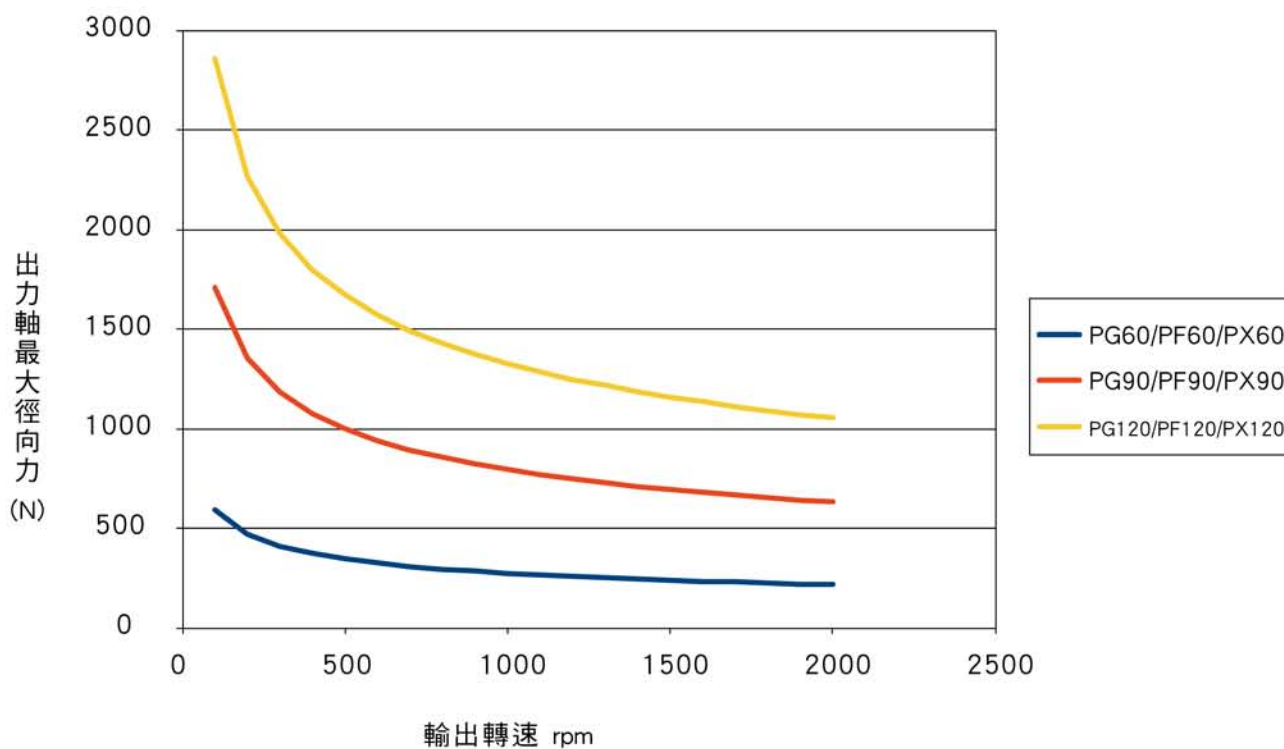

負載係數表 (PG/PF/PX)

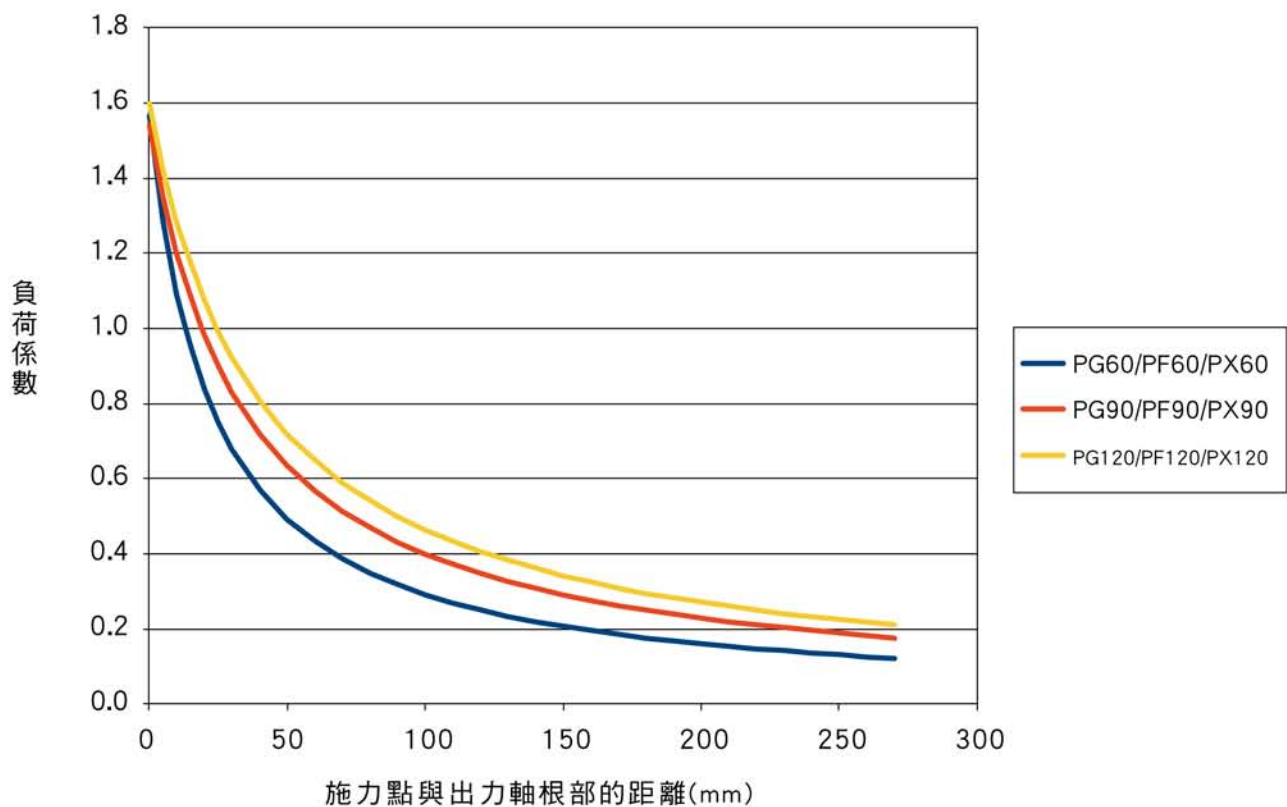

P系列 齒輪箱選用參考表(依據伺服馬達輸出功率選擇)																					
馬達功率	齒輪箱型號	比數																			
		1/3	1/4	1/5	1/7	1/9	1/10	1/12	1/15	1/16	1/20	1/21	1/25	1/28	1/30	1/35	1/40	1/49	1/50	1/70	1/100
100W	PG60	●	●	●	●	●	●	●	●	●	●	●	●	●	●	●	●	●	●	●	●
200W	PG60	●	●	●	●	●	●	●	●	●	●	●	●	●	●	●	●	●	●	●	●
400W	PG60	●	●	●	●	●	●	●	●	●	●	●	●	●	●	●	●	●	●	●	●
	PG90	●	●	●	●	●	●	●	●	●	●	●	●	●	●	●	●	●	●	●	●
500W	PG90	●	●	●	●	●	●	●	●	●	●	●	●	●	●	●	●	●	●	●	●
	PG120	●	●	●	●	●	●	●	●	●	●	●	●	●	●	●	●	●	●	●	●
750W	PG90	●	●	●	●	●	●	●	●	●	●	●	●	●	●	●	●	●	●	●	●
	PG120	●	●	●	●	●	●	●	●	●	●	●	●	●	●	●	●	●	●	●	●
1KW	PG120	●	●	●	●	●	●	●	●	●	●	●	●	●	●	●	●	●	●	●	●
1.5KW	PG120	●	●	●	●	●	●	●	●	●	●	●	●	●	●	●	●	●	●	●	●

備註：

1. 可以依馬達輸出功率選用該比數有●記號之齒輪箱型號。
2. 當應用於扭矩或慣性矩較大之場合，必須選用較大一級齒輪箱。
3. 上表未列出之比數，如有需要請洽詢業務工程師。

P系列 比數選擇			
齒輪箱型號	比數		
	一段式比數 (L1)	二段式比數 (L2)	三段式比數 (L3)
PG60 PF60 PX60	3, 4, 5, 7, 10	9, 12, 15, 16, 20, 21, 25, 28, 30, 35, 40, 49, 50, 70, 100	
PG90 PF90 PX90	3, 4, 5, 7, 10	9, 12, 15, 16, 20, 21, 25, 28, 30, 35, 40, 49, 50, 70, 100	27, 36, 45, 48, 60, 75, 80, 90
PG120 PF120 PX120	3, 4, 5, 7, 10	9, 12, 15, 16, 20, 21, 25, 28, 30, 35, 40, 49, 50, 70, 100	27, 36, 45, 48, 60, 75, 80, 90

直接選用上表中齒輪箱不同段數之比數

P系列 技術規格						
規格	單位	段數	比數	PG60/PF60/PX60	PG90/PF90/PX90	PG120/PF120/PX120
額定輸出扭矩	Nm	L1	3	15	79	190
			4	21	88	230
			5	20	85	215
			7	18	82	205
			10	15	79	190
		L2	9	15	79	190
			15	15	79	190
			20	21	88	230
			25	20	85	215
			35	20	85	215
			40	21	88	230
			49	18	82	205
		L3	70	18	82	205
			100	15	79	190
			27	—	88	230
			36	—	79	190
			45	—	79	190
			48	—	79	190
60	—	79	190			
75	—	79	190			
80	—	88	230			
急停扭矩	Nm	L1, L2, L3	3-100	2.5倍額定輸出扭矩		
額定輸入轉速	rpm	L1, L2, L3	3-100	3,000	3,000	2,000
最大輸入轉速	rpm	L1, L2, L3	3-100	4,500	4,500	3,000
標準背隙	arcmin	L1	3-10	≤15-20	≤12-17	≤12-17
		L2	9-100	≤17-22	≤15-20	≤15-20
扭轉剛性	Nm/arcmin	L1, L2, L3	3-100	2	7.2	14
容許徑向力	N	L1, L2, L3	3-100	590	1,700	2,850
容許軸向力	N	L1, L2, L3	3-100	325	840	1,470
平均使用壽命	hr	L1, L2, L3	3-100	20,000		
全負載時效率	%	L1	3-10	≥ 94%		
		L2	9-100	≥ 91%		
		L3	27-100	≥ 86%		
淨重	kg	L1	3-10	1.1	3.6	8.6
		L2	9-100	1.4	5.4	10.9
		L3	27-100	—	7.3	13.2
使用溫度	°C	L1, L2, L3	3-100	- 10°C ~ + 90°C		
潤滑		L1, L2, L3	3-100	全合成潤滑油脂		
安裝方向		L1, L2, L3	3-100	任意方向		
噪音值	dBA	L1, L2, L3	3-100	≤70	≤70	≤70

- 上述單段齒輪箱(未指定比數)相關規格，主要為使用各型號5比齒輪箱所測得之數據。
- 減速比： $i = \text{輸入轉速}/\text{輸出轉速}$ 。
- 背隙值：為在2%額定輸出扭矩下測試所得之數據。
- 最大徑向力及最大軸向力：施力於出力軸中心位置，週期負載時間50%，轉速100rpm，條件下所測得之數據。
- 運轉負載週期<60%狀況下，平均使用壽命如列表數據值；負載週期≥60%之連續運轉狀況下，平均使用壽命可能會降低至正常值的50%以下。
- 噪音值：距離1公尺，空載運轉，額定輸入轉速，條件下所測得之數據。

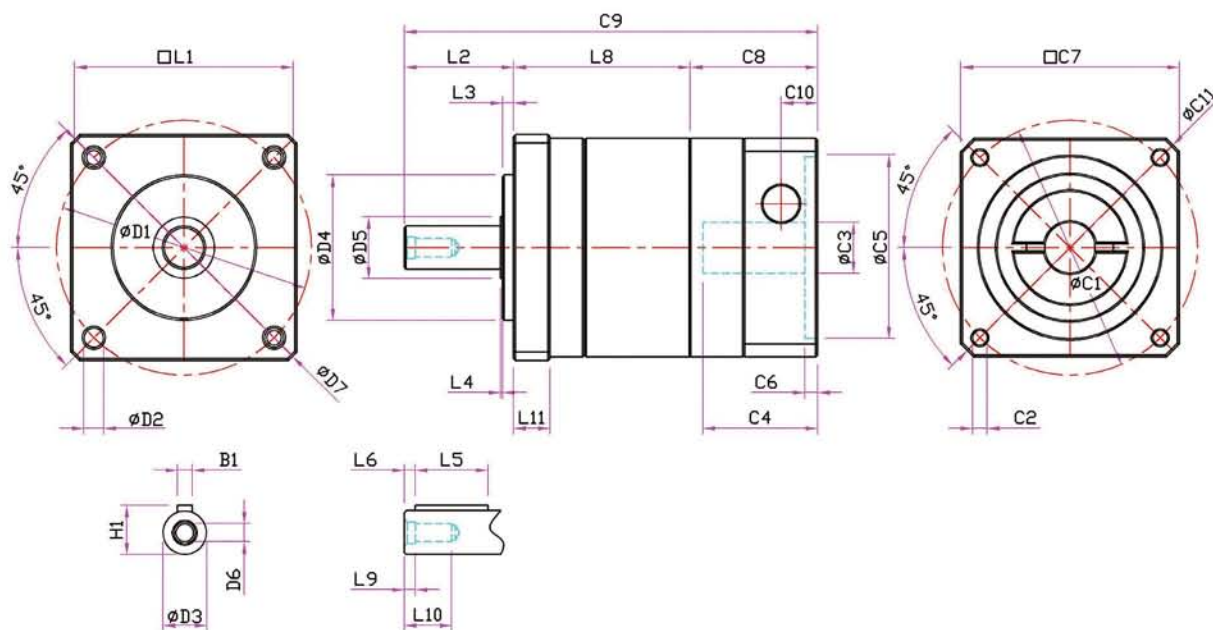

(單位：mm)

尺寸		PF60	PF90	PF120
D1		70	105	145
D2		5.5	6.8	8.7
D3		12(14)	18(20)	32(24)
D4		40	80	80
D5		17	25	35
D6		M5×0.8P	M6×1P	M8×1.25P
D7		84.5	120	160
L1		62	95	120
L2		30(34)	57	70(60)
L3		3	15	10
L4		1	2	1
L5		20	25	40
L6		3	5	5
L8	一段	48.5	56.5	80
	二段	67	84	114
	三段	—	111.5	148
L9		3	4	4
L10		14	18	20
L11		10	10	15
C1		70	100	145
C2		M5×0.8P(MAX)	M6×1P(MAX)	M8×1.25P(MAX)
C3		6-14	14-19	19-24
C4		31.5	43.5	61.5
C5		50	80	110
C6		3.5	8	7
C7		60	95	120
C8		35	56	72
C9	一段	113.5(117.5)	169.5	222(212)
	二段	132(136)	197	256(246)
	三段	—	224.5	290(280)
C10		10	18	30.5
C11		80	120	160
B1		4(5)	6	10(8)
H1		13.5(16)	20.5(22.5)	35(27)

1. C1-C6 為公制標準馬達連接板尺寸，尺寸依搭配伺服馬達而改變。
2. C1-C6 為標規品最大max尺寸。如超出尺寸屬特規品。請與我司聯絡。

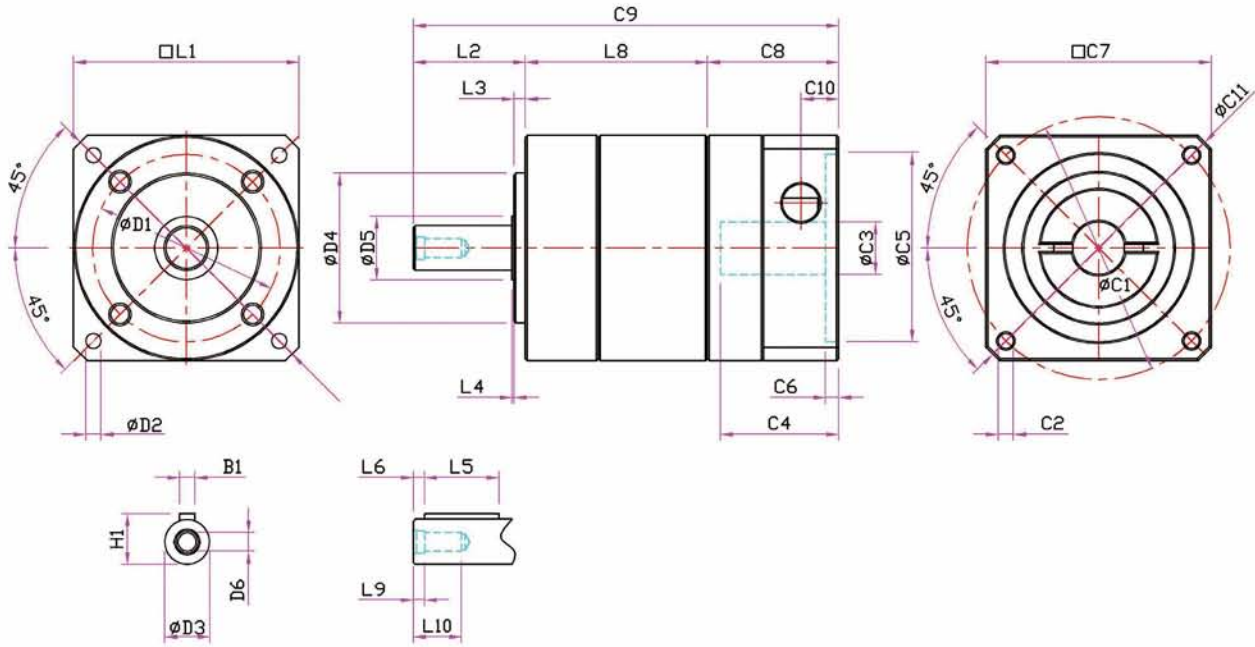

(單位：mm)

尺寸	PX60	PX90	PX120
D1	70	100	145
D2	5.5	6.8	8.7
D3	16(14)	22(20)	32(24)
D4	50	80	110
D5	17	25	35
D6	M5×0.8P	M6×1P	M8×1.25P
D7	84.5	120	160
L1	62	95	120
L2	34	47	70(60)
L3	3	5	10
L4	1	2	1
L5	20	25	40
L6	3	5	5
L8	一段	48.5	66.5
	二段	67	94
	三段	—	121.5
L9	3	4	4
L10	14	18	20
L11	10	10	15
C1	70	100	145
C2	M5×0.8P(MAX)	M6×1P(MAX)	M8×1.25P(MAX)
C3	6-14	14-19	19-24
C4	31.5	43.5	61.5
C5	50	80	110
C6	3.5	8	7
C7	60	95	120
C8	35	56	72
C9	一段	117.5	169.5
	二段	136	197
	三段	—	224.5
C10	10	18	30.5
C11	80	120	160
B1	5	6	10(8)
H1	18(16)	24.5(22.5)	35(27)

1. C1-C6 為公制標準馬達連接板尺寸，尺寸依搭配伺服馬達而改變。
2. C1-C6 為標規品最大max尺寸。如超出尺寸屬特規品。請與我司聯絡。

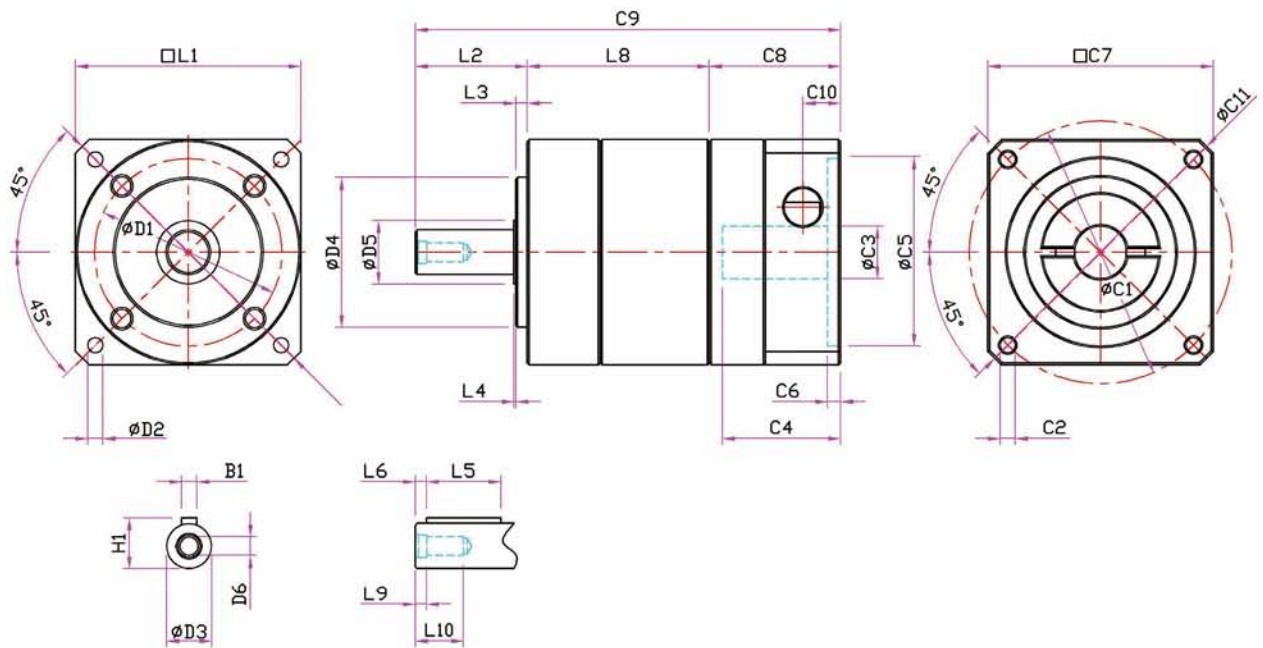

(單位: mm)

尺寸		PG60	PG90	PG120
D1		50	70	100
D2		M5	M6	M10
D3		12(14)	18(20)	32(24)
D4		40	60	80
D5		17	25	35
D6		M5×0.8P	M6×1P	M8×1.25P
L1		60	95	120
L2		30(34)	47	70(60)
L3		3	5	10
L4		1	2	1
L5		20	25	40
L6		3	5	5
L8	一段	48.5	66.5	80
	二段	67	94	114
	三段	—	121.5	148
L9		3	4	4
L10		14	18	20
C1		70	100	145
C2		M5×0.8P(MAX)	M6×1P(MAX)	M8×1.25P(MAX)
C3		6-14	14-19	19-24
C4		31.5	43.5	61.5
C5		50	80	110
C6		3.5	8	7
C7		60	95	120
C8		35	56	72
C9	一段	113.5(117.5)	169.5	222(212)
	二段	132(136)	197	256(246)
	三段	—	224.5	290(280)
C10		10	18	30.5
C11		80	120	160
B1		4(5)	6	10(8)
H1		13.5(16)	20.5(22.5)	35(27)

1. C1-C6 為公制標準馬達連接板尺寸，尺寸依搭配伺服馬達而改變。
2. C1-C6 為標規品最大max尺寸。如超出尺寸屬特規品。請與我司聯絡。

產品特性

MFL產品應用於精密定位或佳復定位，穩定將動力平穩輸出於振動極小的自動化設備上
如：印刷產業、彎管設備、彈簧機產業、LCD檢驗設備、連結滾珠導螺桿傳動結構上…等

齒輪箱

採用鎳鉻合金鋼及一體成型設計，精密度高及輸出扭矩大，具高抗蝕效果



出力軸

採用一體成型設計確保大扭力輸出之結構剛性
表面用無電解鎳處理，具備高防鏽蝕的功能



太陽齒

選用鎳鉻鉬合金鋼
齒面經滲碳處理，耐磨性高及耐高衝擊
齒型精修處理能提升齒輪精度及降低噪音



行星齒

選用鎳鉻鉬合金鋼
齒面經滲碳處理
耐磨性高及耐高衝擊
齒型精修處理
能提升齒輪精度及降低噪音
內孔使用不含保持器的
滿針滾針具高耐磨與高強度



A 轉向本體

特殊加工，能確保轉軸的組裝同心度與入力軸的垂直度
本體使用鋁合金設計大幅降低整體結構重量，表面陽極處理提高防氧化效果



1 雙軸承設計

增加輸入的穩定性

2 入力軸

模組化設計能搭配各廠牌
伺服馬達出力軸
表面染黑處理

3 連接法蘭

採用模組化設計，適合各
式伺服馬達組裝
表面採噴砂陽極或高等級
烤漆技術處理，提高防氧
化效果



B 轉軸

採用鉻鉬合金鋼

C 螺旋傘齒輪

使用鎳鉻鉬合金鋼，表面滲碳處理，具
耐磨與高衝擊特性

D 滾珠軸承

轉軸簡支樑的支點使用滾珠軸承較滾針
軸承有更大的支撐與壽命

A—D 後端整體結構

此一傘齒輪背隙調整結構可同時調整軸
承及傘齒輪的組裝背隙
專利號碼：M441754

減速機型號 (MFL)

MFL
系列

MFL60 - L1 - 10 - M - K - MOTOR

Model:
MFL60
MFL90
MFL120

段數:
L1: 一段比數
L2: 二段比數

背隙:
M: 標準背隙
H: 精密背隙

軸型式:
K: 出力軸有鍵
S: 出力軸為光軸

伺服/步進馬達
廠牌/型號

減速比:
明細請參考MFL 各型號性能資料表
內的減速比組成

MFL 減速比選擇

減速機型號	減速比	
	一段式減速比(L1)	二段式減速比(L2)
MFL60	3, 4, 5, 6, 7, 8, 9, 10, 14, 20	25, 30, 35, 40, 45, 50, 60, 70, 80, 90, 100, 120, 140, 180, 200
MFL90	3, 4, 5, 6, 7, 8, 9, 10, 14, 20	25, 30, 35, 40, 45, 50, 60, 70, 80, 90, 100, 120, 140, 180, 200
MFL120	3, 4, 5, 6, 7, 8, 9, 10, 14, 20	25, 30, 35, 40, 45, 50, 60, 70, 80, 90, 100, 120, 140, 180, 200

MFL減速機轉動慣量表

機型	入力齒輪比	轉動慣量J1 kg*cm ²
MFL60	1:1	0.11
	1:2	0.10
MFL90	1:1	1.31
	1:2	1.15
MFL120	1:1	2.91
	1:2	2.48

MFL技術規格表						
規格	單位	段數	減速比	MFL60	MFL90	MFL120
額定輸出扭矩 T_{2N}	Nm	L1	3	34	116	228
			4	35	120	236
			5	34	117	229
			6	33	113	222
			7	33	110	214
			8	35	100	236
			9	31	107	203
			10	29	94	184
			14	33	110	214
			20	29	94	184
		L2	25	34	117	229
			30	34	113	228
			35	34	117	229
			40	35	120	236
			45	31	107	203
			50	34	117	229
			60	33	113	222
			70	33	110	214
			80	35	100	236
			90	31	107	203
100	29	94	184			
120	33	113	222			
140	29	94	184			
180	31	107	203			
200	29	94	184			
急停扭矩	Nm	L1, L2	3-200	3 倍額定輸出扭矩		
額定輸入轉速 n_{1N}	rpm	L1, L2	3-200	3,000	3,000	2,500
最大輸入轉速 n_{1B}	rpm	L1, L2	3-200	6,000	6,000	5,000
精密背隙 H	arcmin	L1	3-20	≤ 4	≤ 4	≤ 4
		L2	25-200	≤ 7	≤ 7	≤ 7
標準背隙 M	arcmin	L1	3-20	≤ 6	≤ 6	≤ 6
		L2	25-200	≤ 9	≤ 9	≤ 9
扭轉剛性	Nm/arcmin	L1, L2	3-200	4	11	35
容許徑向力 F_{rB}	N	L1, L2	3-200	1,328	2,340	4,000
容許軸向力 F_{aB}	N	L1, L2	3-200	664	1,170	2,000
保固期	M	L1, L2	3-200	1 年		
全負載時效率 η	%	L1	3-20	$\geq 94\%$		
		L2	25-200	$\geq 91\%$		
淨重	kg	L1	3-20	2.26	6.85	13.5
		L2	25-200	2.56	8.05	15.88
使用溫度	°C	L1, L2	3-200	-10°C ~ +90°C		
潤滑		L1, L2	3-200	鋰基複合全合成潤滑油脂		
安裝方式		L1, L2	3-200	任意方向		
防護等級		L1, L2	3-200	IP65		
噪音值	dBA	L1, L2	3-200	≤ 68	≤ 70	≤ 70

- 上述單段減速機(未指定比數)相關規格，主要為使用各型號5比減速機所測得之數據。
- 減速比： $i = \text{輸入轉速} / \text{輸出轉速}$ 。
- 背隙值：為在2%額定輸出扭矩下測試所得之數據。
- 最大徑向力及最大軸向力：施力於出力軸中心位置，週期負載時間50%，輸出轉速100rpm，條件下所測得之數據。
- 運轉負載週期 $< 60\%$ 狀況下，平均使用壽命如列表數據值；負載週期 $\geq 60\%$ 之連續運轉狀況下，平均使用壽命可能會降低至正常值的50%以下。
- 噪音值：距離1公尺，空載運轉，額定輸入轉速，條件下所測得之數據。

容許徑向力：垂直於軸心的力量
容許軸向力：平行於軸心的力量

容許徑/軸向力與減速機的出力軸轉速及施力點的距離相關

a：轉速越快，容許徑向力會降低

b：負載的距離越遠，容許的徑向力也隨之降低

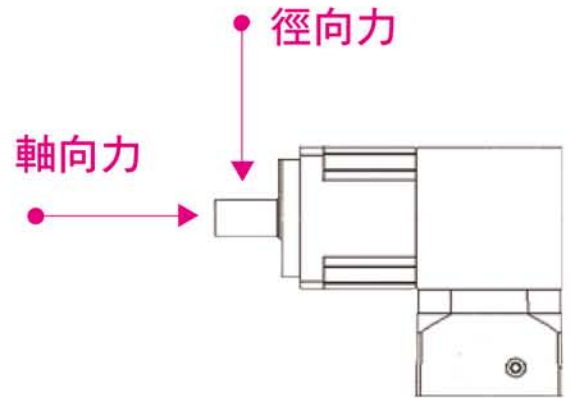

徑向負荷表 (MFL)

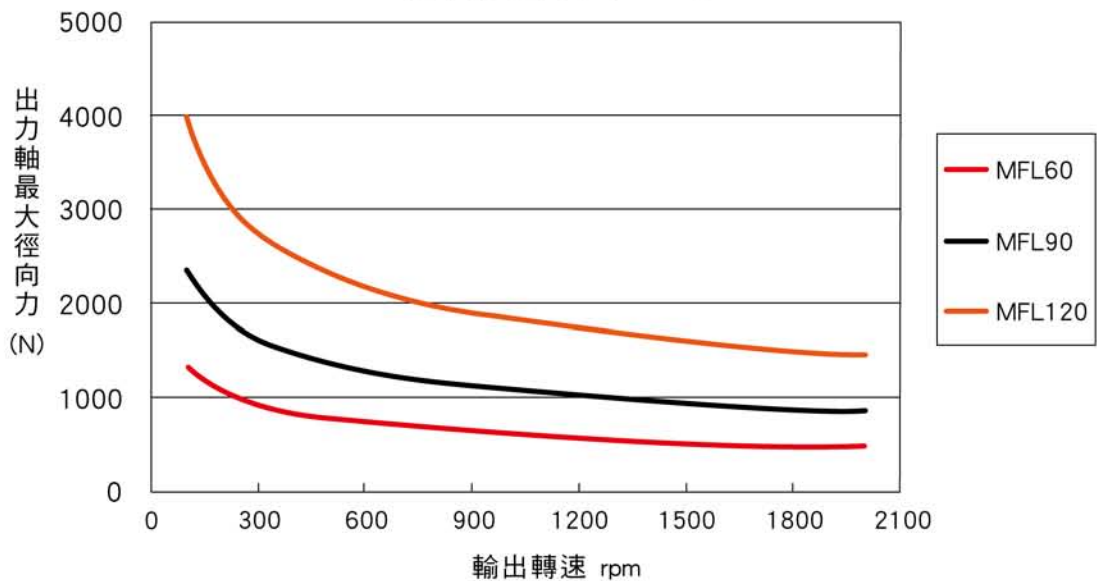

負載係數表 (MFL)

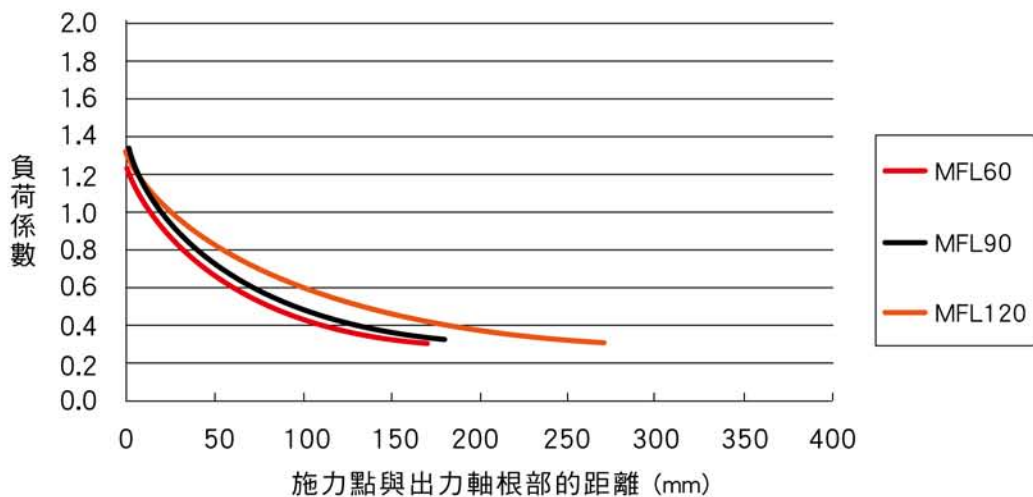

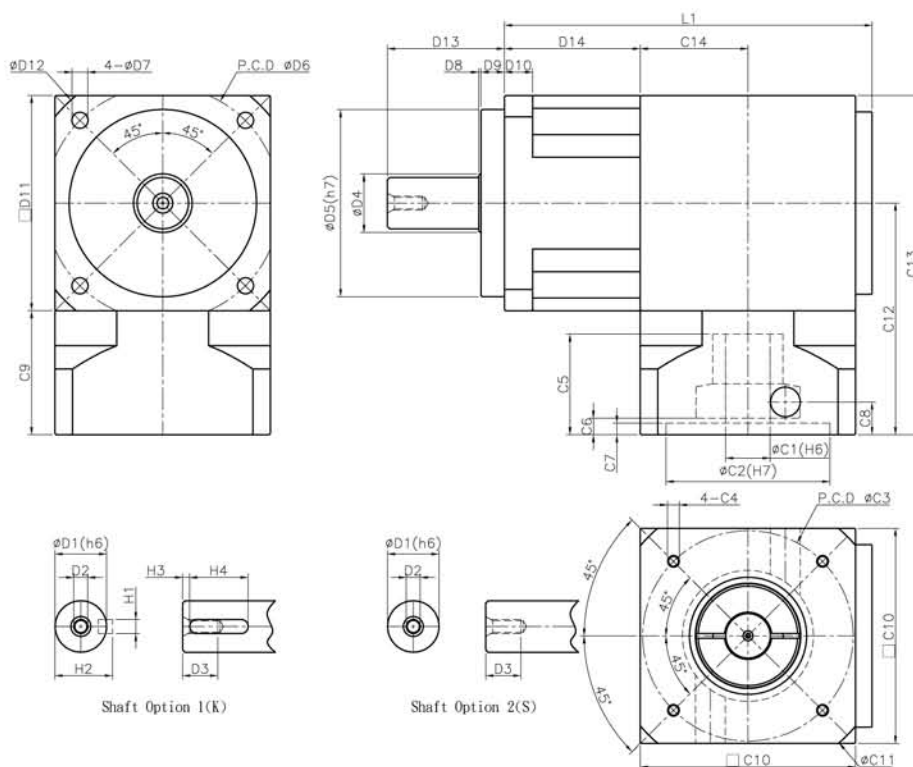

(單位：mm)

尺寸	MFL60	MFL90	MFL120
D1	16	22	32
D2	M5x0.8P	M6x1.0P	M8x1.25P
D3	12	15	20
D4	18	25	35
D5	50	80	110
D6	70	100	130
D7	5.5	6.8	8.7
D8	1.5	1	1
D9	7.5	10	12
D10	10	12	15
D11	60	92	120
D12	80	118	158
D13	35.5	50	65
D14	49	58	69
H1	5	6	10
H2	18	24.5	35
H3	3	5	3
H4	20	25	40
L1	一段	114	157
	二段	130	184.5
C1	6-14	14-19	16-24
C2	50	70	110
C3	70	90	145
C4	M5x0.8P(MAX)	M6x1.0P(MAX)	M8x1.25P(MAX)
C5	40	44	65
C6	6	7	20
C7	4	5	7
C8	12	14	28.5
C9	45	53	78
C10	60.4	92	120
C11	80	120	161
C12	75	99	138
C13	105	145	198
C14	31	46	60

1. 以上C1-C11 為標準的連接法蘭尺寸，實際尺寸會因馬達型號不同而變動。
2. C1-C6 為標規品最大max尺寸。如超出尺寸屬特規品。請與我司聯絡。

A—C 後端整體結構

此一傘齒輪背隙調整結構可同時調整軸承及傘齒輪的組裝背隙
專利號碼：M441754



A 轉向本體

特殊加工能確保轉軸的組裝同心度與入力軸的垂直度
本體使用鋁合金設計大幅降低整體結構重量，表面陽極處理提高防氧化效果

B 螺旋傘齒輪

使用鎳鉻鉬合金鋼，表面滲碳處理，具耐磨與高衝擊特性

C 出力軸

使用鉻鉬合金鋼，表面採化學鎳處理
出力軸有空軸(MFT-S0)、單邊軸(MFT-S1)及雙邊軸(MFT-S2)

產品特性

MFT產品應用於精度定位或往復定位，穩定將動力平穩輸出於振動極小的自動化設備上。
如：印刷產業、彎管設備、彈簧機產業、LCD檢驗設備、連結滾珠導螺桿傳動結構上…等



1 太陽齒

選用鎳鉻鉬合金鋼，齒面經滲碳處理，耐磨性高及耐高衝擊
齒型精修處理能提升齒輪精度及降低噪音

2 減速軸

採用一體成型設計確保大扭力輸出之結構剛性

3 行星齒

選用鎳鉻鉬合金鋼，齒面經滲碳處理，耐磨性高及耐高衝擊
齒型精修處理，能提升齒輪精度及降低噪音
內孔使用不含保持器的滿針滾針具高耐磨與高強度

4 齒輪箱

採用鉻鉬合金鋼及一體成型設計，精密度高及輸出扭矩大，具高抗蝕效果

5 入力軸

模組化設計能搭配各廠牌伺服馬達出力軸
表面染黑處理

6 連接法蘭

採用模組化設計，適合各式伺服馬達組裝
表面採噴砂陽極或高等級烤漆技術處理，提高防氧化效果

減速機型號 (MFT)

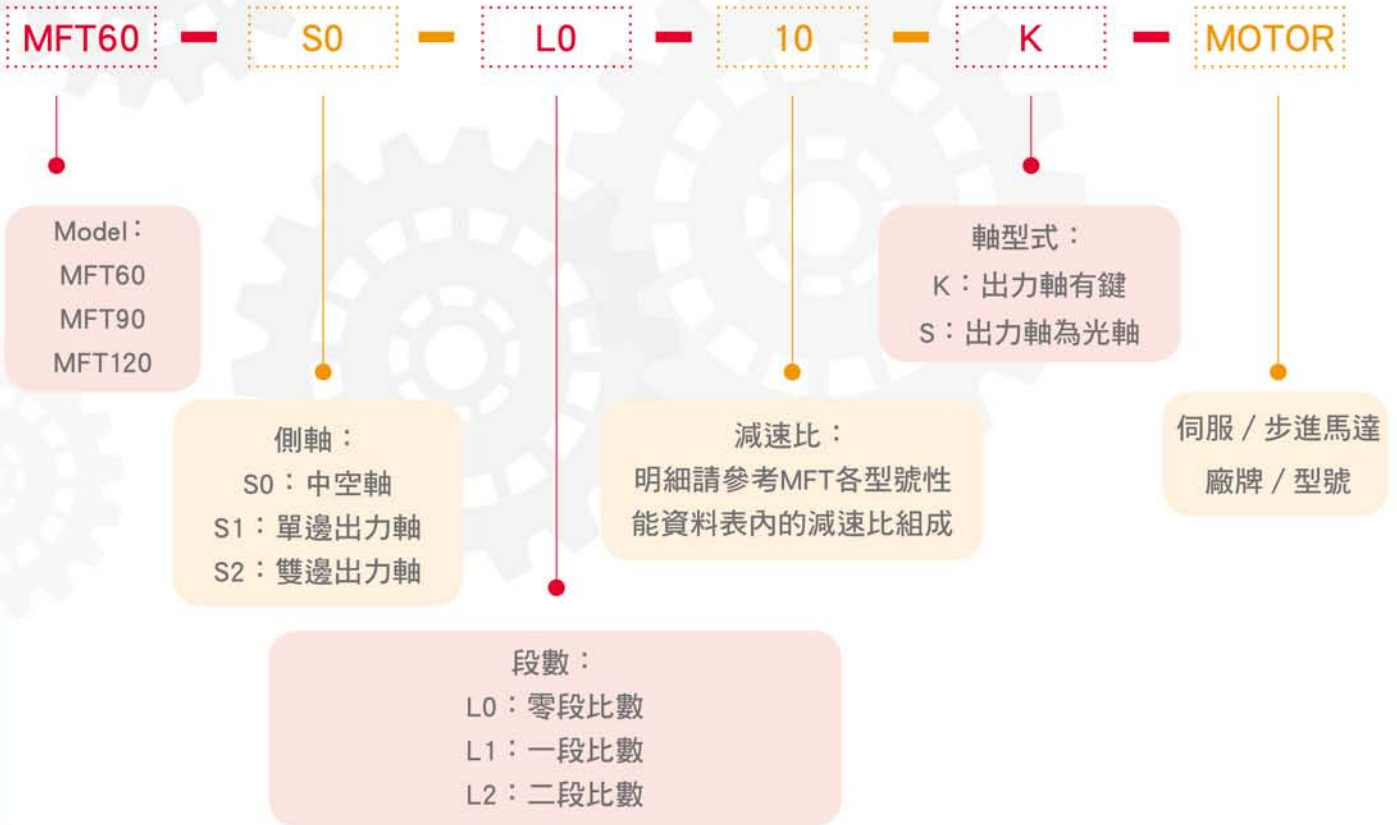

MFT 系列

MFT 減速比選擇

減速機型號	減速比		
	零段式減速比(L0)	一段式減速比(L1)	二段式減速比(L2)
MFT60	1	3, 4, 5, 7, 10	15, 20, 25, 30, 35, 40, 50, 70, 100
MFT90	1	3, 4, 5, 7, 10	15, 20, 25, 30, 35, 40, 50, 70, 100
MFT120	1	3, 4, 5, 7, 10	15, 20, 25, 30, 35, 40, 50, 70, 100



轉動慣量 J_1 kg*cm ²	段數	減速比	MFT60	MFT90	MFT120	
	L0	1	1	0.274	2.14	6.05
3		3	0.14	1.25	3.28	
4		4	0.11	1.14	2.89	
5		5	0.10	1.11	2.81	
L1		6	—	—	—	—
		7	0.10	1.10	2.76	
		8	—	—	—	
		9	—	—	—	
		10	0.10	1.10	2.74	
		L2	15	—	—	1.11
20	—		—	1.11	2.81	
25	—		—	1.11	2.81	
30	—		—	1.10	2.74	
35	0.10		1.10	2.76		
40	—		—	1.10	2.74	
50	—		—	1.10	2.74	
70	—		—	1.10	2.74	
100	—		—	1.10	2.74	

規格	單位	段數	減速比	MFT60	MFT90	MFT120
額定輸出扭矩 T_{2N}	Nm	L0	1			
	Nm	L1	3-10	15	58	114
	Nm	L2	15-100			
急停扭矩	Nm	L0 · L1 · L2	1-100	1.5 倍額定輸出扭矩		
額定輸入轉速 n_{1N}	rpm	L0 · L1 · L2	1-100	3,000	3,000	3,000
最大輸入轉速 n_{1B}	rpm	L0 · L1 · L2	1-100	6,000	6,000	6,000
標準背隙 M	arcmin	L0	1	≤ 6	≤ 6	≤ 6
		L1	3-10	≤ 8	≤ 8	≤ 8
		L2	15-100	≤ 10	≤ 10	≤ 10
容許徑向力 F_{rB}	N	L0	1	810	1,220	2,080
	N	L1 · L2	3-100	1,108	1,688	2,900
容許軸向力 F_{aB}	N	L0	1	381	610	1,040
	N	L1 · L2	3-100	584	844	1,450
保固期	M	L0 · L1 · L2	1-100	1 年		
全負載時效率 η	%	L0	1	≥ 98%		
		L1	3-10	≥ 95%		
		L2	15-100	≥ 92%		
淨重	kg	L0	中空軸 S0	1.85	4.29	9.05
			單邊軸 S1	1.98	4.65	9.66
			雙邊軸 S2	2	4.71	9.77
		L1	中空軸 S0	2.05	6.47	13.8
			單邊軸 S1	2.18	6.83	14.41
			雙邊軸 S2	2.2	6.89	14.52
		L2	中空軸 S0	2.35	7.6	16.4
			單邊軸 S1	2.48	7.95	17.01
			雙邊軸 S2	2.5	8.01	17.12
使用溫度	°C	L0 · L1 · L2	1-100	-10°C ~ +90°C		
潤滑		L0 · L1 · L2	1-100	鋰基複合全合成潤滑油脂		
安裝方向		L0 · L1 · L2	1-100	任意方向		
防護等級		L0 · L1 · L2	1-100	IP65		
噪音值 (轉速=1500 rpm)	dBA	L0	1	≤ 73	≤ 76	≤ 79
	dBA	L1 · L2	3-100	≤ 65	≤ 65	≤ 65

1. 減速比：i=輸入轉速/輸出轉速。
2. 背隙值：為在2%額定輸出扭矩下測試所得之數據。
3. 最大徑向力及最大軸向力：施力於出力軸中心位置，週期負載時間50%，輸出轉速100rpm，條件下所測得之數據。
4. 運轉負載週期<60%狀況下，平均使用壽命如列表數據值；負載週期≥60%之連續運轉狀況下，平均使用壽命可能會降低至正常值的50%以下。
5. 噪音值：距離1公尺，空載運轉，額定輸入轉速，條件下所測得之數據。

容許徑向力：垂直於軸心的力量
容許軸向力：平行於軸心的力量

容許徑/軸向力與減速機的出力軸轉速及施力點的距離相關

a：轉速越快，容許徑向力會降低

b：負載的距離越遠，容許的徑向力也隨之降低

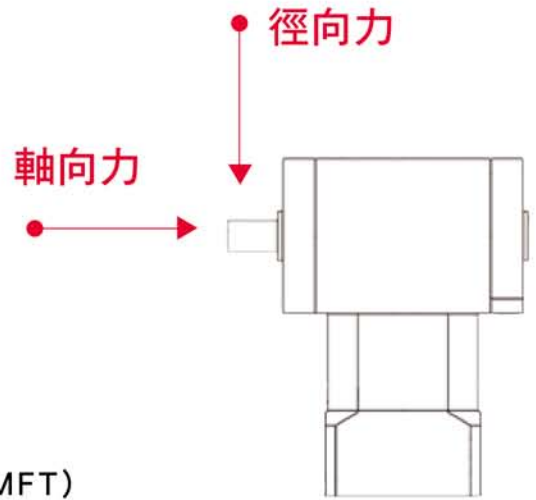

MFT 系列

徑向負荷表 (MFT)

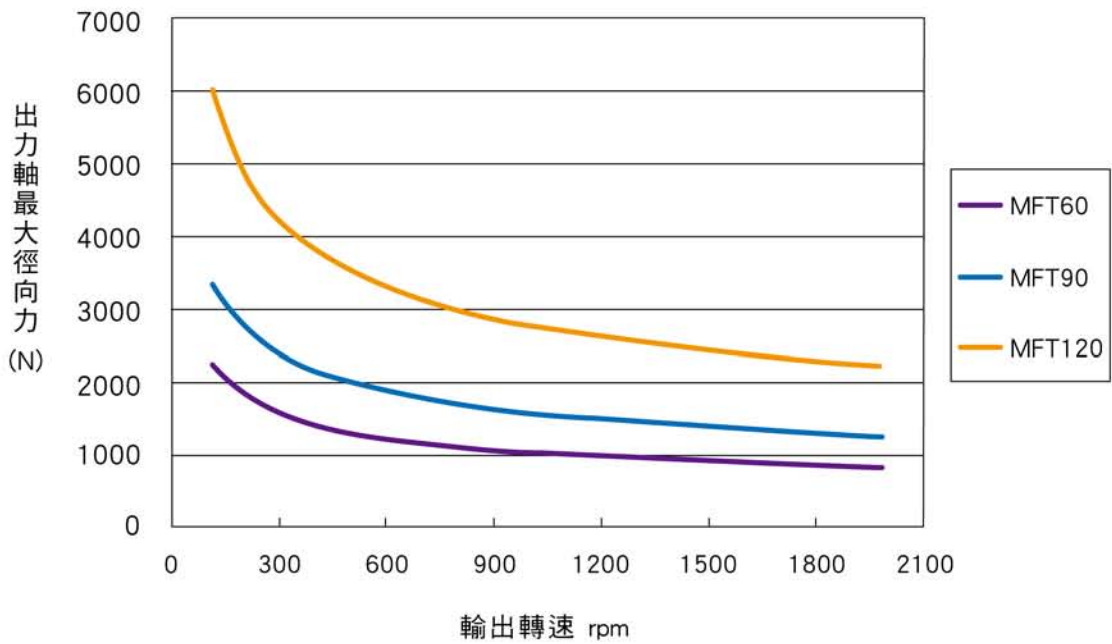

負載係數表 (MFT)

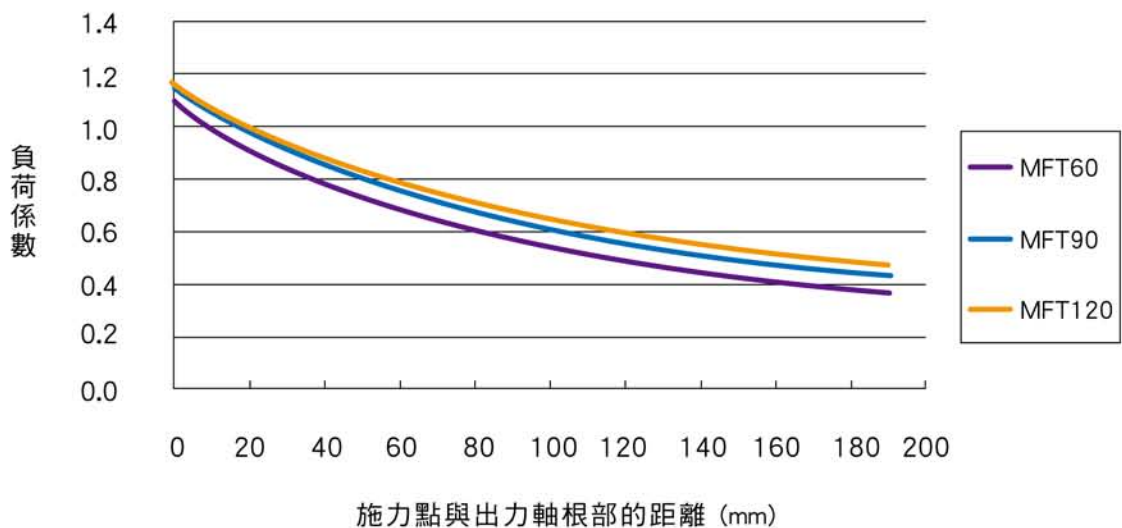

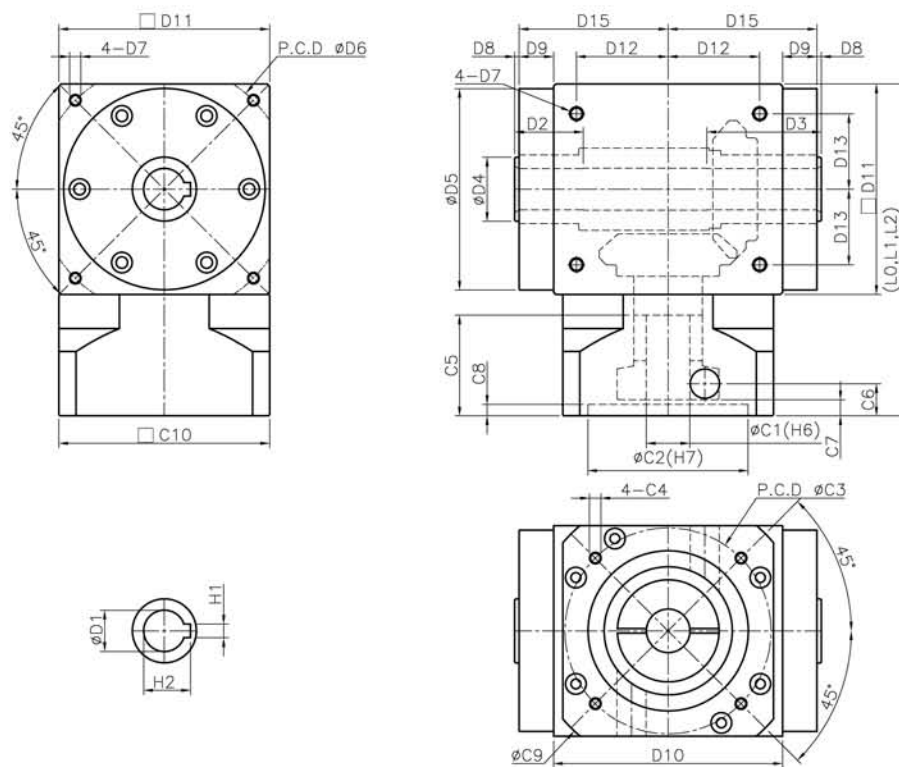

(單位：mm)

尺寸	MFT60-S0	MFT90-S0	MFT120-S0
ØD1	13	18	22
D2	30	30	35
D3	30	50	55
ØD4	20	28	35
ØD5	62	88	108
ØD6	76	110	145
D7	M4x0.7P	M6x1.0P	M8x1.25P
D8	2	2	2
D9	13	15	15
D10	70	100	126
D11	62	92	120
D12	25	40	50
D13	25	33	42
D15	48	65	78
H1	5	6	6
H2	15.3	20.8	24.8
L0 零段	101.5	141	198
L1 一段	130	185.5	254
L2 二段	146	213	287.2
ØC1	6-14	14-19	16-24
ØC2	50	70	110
ØC3	70	90	145
C4	M5x0.8P(MAX)	M6x1.0P(MAX)	M8x1.25P(MAX)
C5	33	39	65
C6	13	15	28.5
C7	7	7	20
C8	4	5	7
ØC9	80	120	161
C10	60	92	120

1. 以上C1-C10 為標準的連接法蘭尺寸，實際尺寸會因馬達型號不同而變動。
2. C1-C6 為標規品最大max尺寸。如超出尺寸屬特規品。請與我司聯絡。

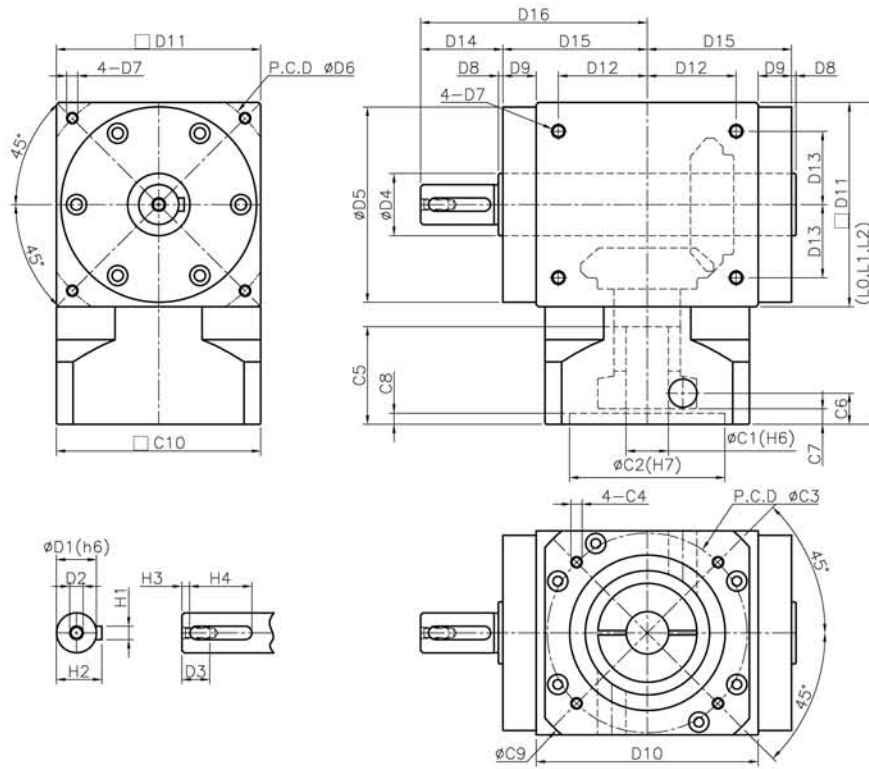

(單位：mm)

尺寸	MFT60-S1	MFT90-S1	MFT120-S1
ØD1	13	18	22
D2	M4x0.7P	M5x0.8P	M8x1.25P
D3	12	14.5	22
ØD4	20	28	35
ØD5	62	88	108
ØD6	76	110	145
D7	M4x0.7P	M6x1.0P	M8x1.25P
D8	2	2	2
D9	13	15	15
D10	70	100	126
D11	62	92	120
D12	25	40	50
D13	25	33	42
D14	22	37	42
D15	48	65	78
D16	70	102	120
H1	5	6	6
H2	15	20.5	24.5
H3	2	3.5	5
H4	16	25	25
L0 零段	101.5	141	198
L1 一段	130	185.5	254
L2 二段	146	213	287.2
ØC1	6~14	14~19	16~24
ØC2	50	70	110
ØC3	70	90	145
C4	M5x0.8P(MAX)	M6x1.0P(MAX)	M8x1.25P(MAX)
C5	33	39	65
C6	13	15	28.5
C7	7	7	20
C8	4	5	7
ØC9	80	120	161
C10	60	92	120

1. 以上C1-C10 為標準的連接法蘭尺寸，實際尺寸會因馬達型號不同而變動。
2. C1-C6 為標規品最大max尺寸。如超出尺寸屬特規品。請與我司聯絡。

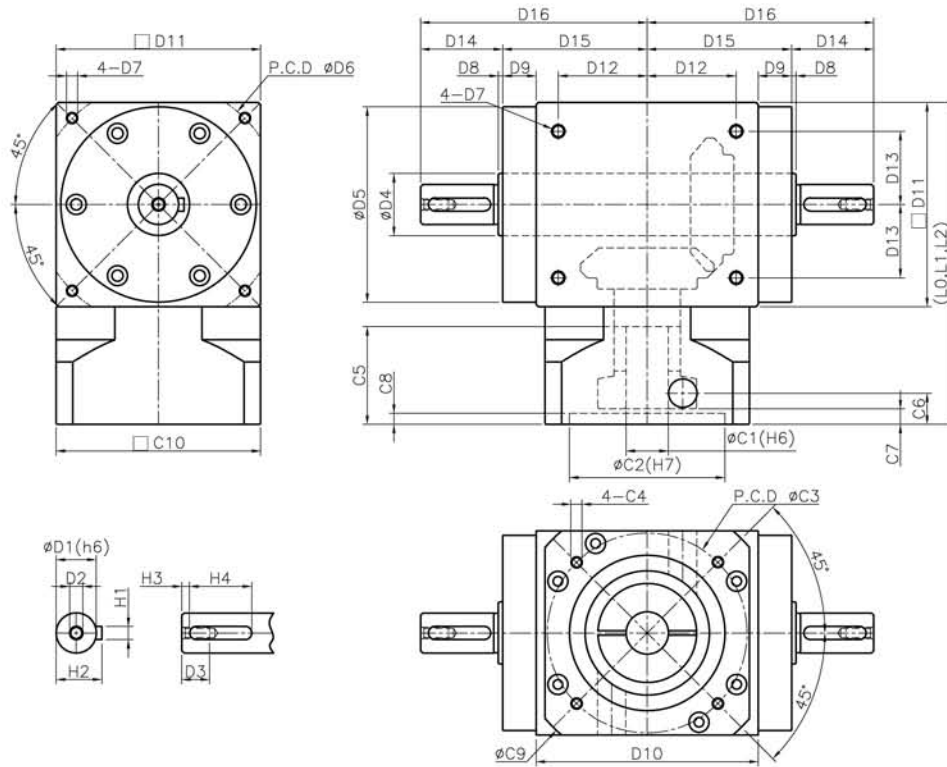

(單位：mm)

尺寸	MFT60-S2	MFT90-S2	MFT120-S2
ØD1	13	18	22
D2	M4x0.7P	M5x0.8P	M8x1.25P
D3	12	14.5	22
ØD4	20	28	35
ØD5	62	88	108
ØD6	76	110	145
D7	M4x0.7P	M6x1.0P	M8x1.25P
D8	2	2	2
D9	13	15	15
D10	70	100	126
D11	62	92	120
D12	25	40	50
D13	25	33	42
D14	22	37	42
D15	48	65	78
D16	70	102	120
H1	5	6	6
H2	15	20.5	24.5
H3	2	3.5	5
H4	16	25	25
L0 零段	101.5	141	198
L1 一段	130	185.5	254
L2 二段	146	213	287.2
ØC1	6-14	14-19	16-24
ØC2	50	70	110
ØC3	70	90	145
C4	M5x0.8P(MAX)	M6x1.0P(MAX)	M8x1.25P(MAX)
C5	33	39	65
C6	13	15	28.5
C7	7	7	20
C8	4	5	7
ØC9	80	120	161
C10	60	92	120

1. 以上C1-C10 為標準的連接法蘭尺寸，實際尺寸會因馬達型號不同而變動。
2. C1-C6 為標規品最大max尺寸。如超出尺寸屬特規品。請與我司聯絡。

減速機快選法

週期性運轉 (S5)

(每小時運轉週期數 ≤ 1000)

負載運轉週期 $< 60\%$ 且 < 20 分鐘

1. 扭矩確認：

$$T_{\text{馬達最大輸出扭矩}} \times i_{\text{減速比}} < T_{\text{減速機急停扭矩}}$$

2. 重要尺寸確認：

1. 馬達軸直徑 (C3)
2. 馬達入力引導凸緣直徑 (C5)
3. 馬達軸長度 (C4)
4. 馬達入力引導凸緣深度 (C6)
5. 入力法藍螺絲孔節圓直徑 (C1)
6. 入力法藍螺絲孔規格 (C2)

連續性運轉 (S1)

負載運轉週期 $\geq 60\%$ 或 ≥ 20 分鐘

1. 扭矩確認：

$$T_{\text{馬達額定輸出扭矩}} \times i_{\text{減速比}} < T_{\text{減速機額定輸出扭矩}}$$

2. 轉速確認：

$$N_{\text{馬達額定輸出轉速}} \leq N_{\text{減速機額定輸入轉速}}$$

3. 重要尺寸確認：

1. 馬達軸直徑 (C3)
2. 馬達入力引導凸緣直徑 (C5)
3. 馬達軸長度 (C4)
4. 馬達入力引導凸緣深度 (C6)
5. 入力法藍螺絲孔節圓直徑 (C1)
6. 入力法藍螺絲孔規格 (C2)

第四版1500本 本公司保留規格修改的權利，各項規格如有變動，依產品實物為準，不另行通知。

VGM[®]

東莞市帝仁精密機電有限公司

電話：0769-81125379

郵箱：dgdiren@163.com

網址：www.dgdiren.com

地址：廣東省東莞市大朗大井頭社區金麗路一巷13號
四川省成都市成華區雙桂路