

RenYuan®  
任元



数据手册  
RL, RLF  
立式多级离心泵  
50Hz

任原泵业(杭州)有限公司  
RENYUAN PUMPS HANG ZHOU CO.,LTD

# 公司简介



任原泵业（杭州）有限公司是与台湾任原公司合资成立的一家专业从事开发、设计、生产经营各类水泵及控制设备的股份制企业，是中国农业机械排灌协会会员单位，排灌机械行业的骨干企业，中国泵系统绿色节能产业联盟理事单位。公司自成立以来，始终致力于科技和管理的不断创新，走上了良性循环的规模化经营之路，拥有着一支专业的技术研发队伍；形成了一套完整的生产管理、技术研发、品质控制和营销网络体系。

任原公司与美国富兰克林电气，丹麦格兰富公司强强联合，展开战略合作。任原泵业（杭州）深井泵生产基地位于浙江金华市金东工业区，离心泵生产基地位于浙江德清雷甸工业区，生产各类水泵及控制设备5000多种规格，位居国内外同行前列。产品涉及喷泉、工矿企业、城市供水、农田灌溉、石油化工、高层建筑、消防供水、工业水处理和纯净水、制药、锅炉、空调循环系统等诸多行业。公司技术力量雄厚，工艺装备先进。为构建一个领先的技术研发及贸易平台，阿里巴巴有限公司专业负责产品网络开发。设立泵类专业网站及时发布产品信息，产品设计采用水泵专用设计软件设计。以“追求卓越，奉献百姓”为质量方针的指导下，发展迅猛倍受国内外同行关注。公司在内部建立了完善的质量管理体系，最大限度地实现了企业资源的优化组合和分配。

任原公司在以人为本，永远让顾客满意为目标建立了完备的客户服务体系，在全国建立了二十多个销售，服务网络和产品储备库，竭力为各地用户提供优质、及时、周到的服务，切实做到为用户服务，对用户负责，让用户满意。使顾客满意是我们永远追求的目标。自公司成立以来，视诚信为生命，建立诚信档案，引进了诚信评价管理机制，在要求客户讲信用的同时，强调自己首先讲信用，保证对客户和社会的每一项承诺得到履行。“用户的需求，就是我们的追求”是我公司发展的宗旨；竭诚欢迎国内外客商来电来函洽谈业务。

当您翻开画册的每一页  
给你的不仅是惊喜，更是信任和承诺！

---

|                      |    |
|----------------------|----|
| * RL1/RLF1 .....     | 9  |
| * RL2/RLF2 .....     | 11 |
| * RL3/RLF3 .....     | 13 |
| * RL4/RLF4 .....     | 15 |
| * RL5/RLF5 .....     | 17 |
| * RL8/RLF8 .....     | 19 |
| * RL10/RLF10 .....   | 21 |
| * RL12/RLF12 .....   | 23 |
| * RL15/RLF15 .....   | 25 |
| * RL16/RLF16 .....   | 27 |
| * RL20/RLF20 .....   | 29 |
| * RL32/RLF32 .....   | 31 |
| * RL45/RLF45 .....   | 33 |
| * RL64/RLF64 .....   | 35 |
| * RL90/RLF90 .....   | 37 |
| * RL120/RLF120 ..... | 39 |
| * RL150/RLF150 ..... | 41 |
| * RL200/RLF200 ..... | 43 |
| * RLF+RLH .....      | 45 |



## 性能范围

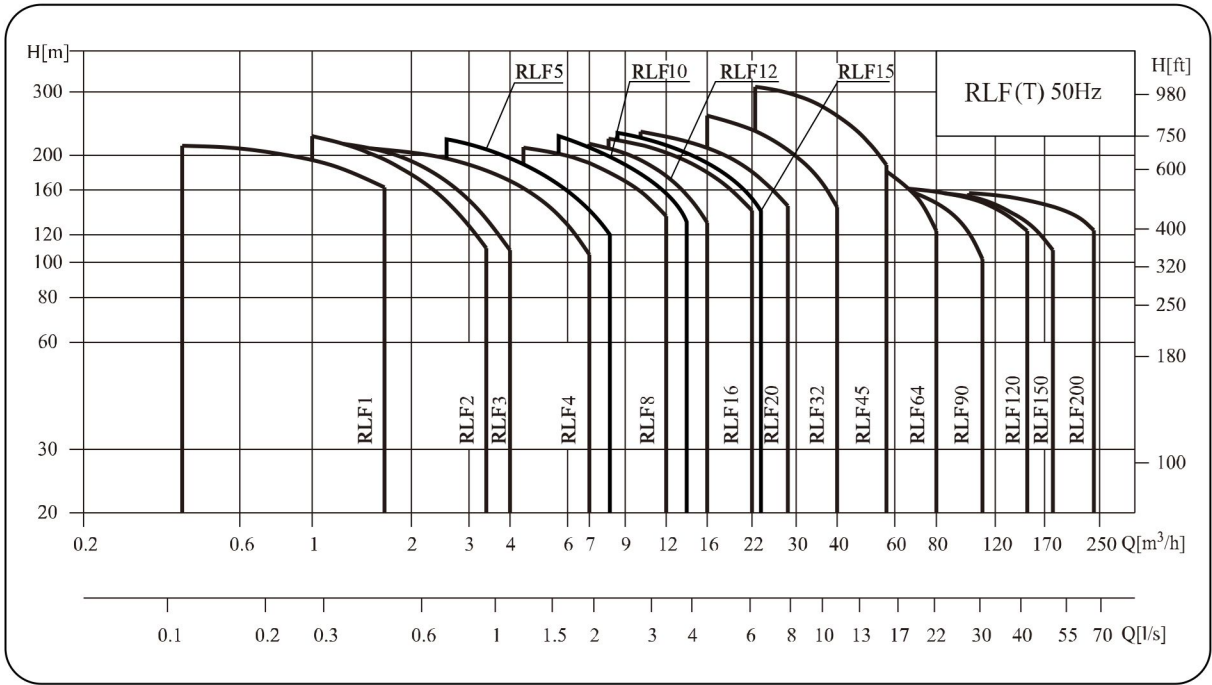

## 产品范围

| 主要参数           | RLF1                 | RLF2                 | RLF3                 | RLF4                 | RLF5                 | RLF8      | RLF10     | RLF12     | RLF15     | RLF16     | RLF20     |
|----------------|----------------------|----------------------|----------------------|----------------------|----------------------|-----------|-----------|-----------|-----------|-----------|-----------|
| 额定流量 $[m^3/h]$ | 1                    | 2                    | 3                    | 4                    | 5                    | 8         | 10        | 12        | 15        | 16        | 20        |
| 额定流量 $[l/s]$   | 0.28                 | 0.56                 | 0.83                 | 1.1                  | 1.39                 | 2.2       | 2.78      | 3.3       | 4.17      | 4.4       | 5.6       |
| 流量范围 $[m^3/h]$ | 0.4~1.8              | 1~3.5                | 1.2~4                | 1.5~7                | 2.5~8.5              | 5~12      | 5~13      | 7~16      | 8~23      | 8~22      | 10~28     |
| 流量范围 $[l/s]$   | 0.11~0.5             | 0.28~0.97            | 0.33~1.1             | 0.42~1.9             | 0.69~2.36            | 1.39~3.3  | 1.39~3.61 | 1.9~4.4   | 2.22~6.39 | 2.2~6.1   | 2.8~7.8   |
| 最大压力 $[bar]$   | 21                   | 23                   | 22                   | 21                   | 24                   | 21        | 23        | 22        | 23        | 22        | 23        |
| 电机功率 $[kW]$    | 0.37~2.2             | 0.37~3               | 0.37~3               | 0.37~4               | 0.37~5.5             | 0.75~7.5  | 0.75~7.5  | 1.5~11    | 1.1~15    | 2.2~15    | 1.1~18.5  |
| 温度范围 $[°C]$    | -15~105              |                      |                      |                      |                      |           |           |           |           |           |           |
| 最高效率 $[%]$     | 44                   | 46                   | 54                   | 58                   | 63                   | 62        | 70        | 63        | 73        | 66        | 69        |
| RLF 管路连接       |                      |                      |                      |                      |                      |           |           |           |           |           |           |
| DIN法兰          | DN25                 | DN25                 | DN25                 | DN32                 | DN32                 | DN40      | DN40      | DN50      | DN50      | DN50      | DN50      |
| 管螺纹            | $R_1 1\frac{1}{4}''$ | $R_1 1\frac{1}{4}''$ | $R_1 1\frac{1}{4}''$ | $R_1 1\frac{1}{4}''$ | $R_1 1\frac{1}{4}''$ | $R_1 2''$ | $R_1 2''$ | $R_1 2''$ | $R_1 2''$ | $R_1 2''$ | $R_1 2''$ |
| 卡套接头           | DN32                 | DN32                 | DN32                 | DN32                 | DN32                 | DN50      | DN50      | DN50      | DN50      | DN50      | DN50      |
| RL 管路连接        |                      |                      |                      |                      |                      |           |           |           |           |           |           |
| DIN法兰          | DN25                 | DN25                 | DN25                 | DN32                 | DN32                 | DN40      | DN40      | DN50      | DN50      | DN50      | DN50      |

| 主要参数                    | RLF32   | RLF45    | RLF64 | RLF90  | RLF120 | RLF150 | RLF200   |
|-------------------------|---------|----------|-------|--------|--------|--------|----------|
| 额定流量[m <sup>3</sup> /h] | 32      | 45       | 64    | 90     | 120    | 150    | 200      |
| 额定流量[l/s]               | 8.9     | 12.5     | 17.8  | 25     | 33.3   | 41.7   | 55.6     |
| 流量范围[m <sup>3</sup> /h] | 16~40   | 25~55    | 30~80 | 50~110 | 60~150 | 80~180 | 100~240  |
| 流量范围[l/s]               | 4.4~11  | 6.9~15.3 | 8~22  | 14~30  | 17~42  | 22~50  | 28~67    |
| 最大压力[bar]               | 26      | 30       | 22    | 17     | 16     | 16     | 16       |
| 电机功率[kW]                | 1.5~30  | 3~45     | 4~45  | 5.5~45 | 11~75  | 11~75  | 18.5~110 |
| 温度范围[°C]                | -15~105 |          |       |        |        |        |          |
| 最高效率[%]                 | 74      | 75       | 76    | 77     | 74     | 73     | 79       |
| 管路连接                    |         |          |       |        |        |        |          |
| DIN法兰                   | DN65    | DN80     | DN100 | DN100  | DN125  | DN125  | DN150    |

## 型号含义

RL, RLF 1/2/3/4/5/8/10/12/15/16/20

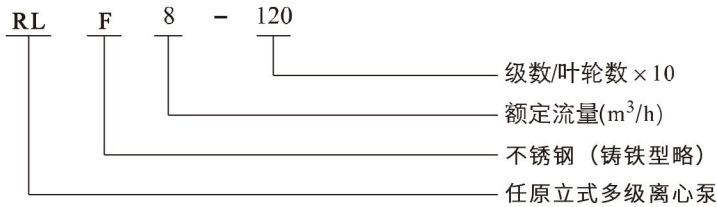

RL, RLF 32/45/64/90/120/150

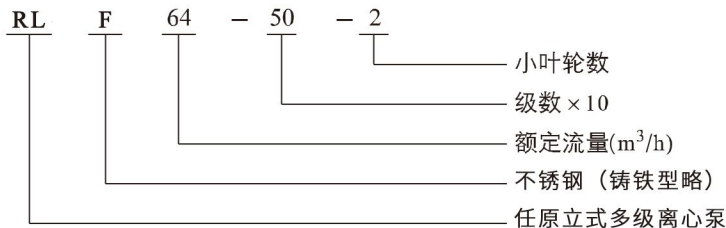

RL, RLF 200

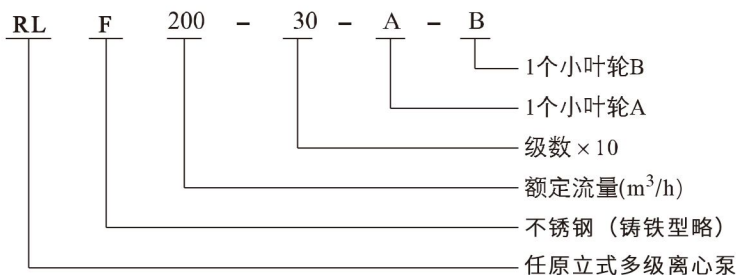

## 典型应用

- **RL, RLF** 泵为立式多级离心泵, 其管道式结构可以确保泵可直接安装在进出在同一水平线上且管径相同的水平管路系统中, 这种设计使泵的结构和管路更为紧凑。
- 任原 **RL, RLF** 泵有不同的泵规格和不同级数, 以满足所需的流量和压力。
- **RL** 是一种多功能产品, 可以输送从自来水到工业液体的各种不同介质, 适用于不同温度、流量和压力范围。
- **RL** 适用于无腐蚀性液体, **RLF** 适用于轻度腐蚀性液体。
- 供水: 水厂过滤与输送、水厂分区送水、主管网增压、高层建筑、宾馆等的增压、工业给水增压。
- 工业增压: 流程水系统、清洗系统、高压冲洗系统、消防系统、汽车清洗。
- 工业液体输送: 冷却和空调系统、锅炉给水和冷凝系统、机床配套。
- 输送: 油和酒精、酸和碱、乙二醇和冷却剂。
- 水处理: 超滤系统、反渗透系统、蒸馏系统、分离器、游泳池。
- 灌溉: 区域灌溉、喷灌、滴灌。

## 电机

- 电机为全封闭，风冷式二级标准电机
- 防护等级：IP55
- 绝缘等级：F
- 标准电压：50Hz:1×220-230/240V  
3×200-220/346-380V  
3×220-240/380-415V  
3×220-255/380-440V
- 其它电压的电机按要求可供。
- 单相电机从0.37~2.2 kW可供。

## 性能曲线

- 所有曲线都基于电机在恒速2900rpm或2950rpm的测量值。
- 曲线容差符合ISO9906，附录A。
- 测试采用20℃不含空气的水，运动粘度1mm<sup>2</sup>/s。
- 泵的使用参照粗线的性能范围，以防流量过小产生过热或流量过大使电机过载等。

## 泵说明

- RLF 为配有标准电机的非自吸式多级离心泵，电机轴和泵轴用联轴器直接联接，把拉杆用螺母将外筒，过流部件固定在支架和进出水体之间，泵进出水口在泵底部的同一直线上。
- 泵可根据需要配置智能保护器，对泵的干转、缺相、过载等进行有效的保护。

## 海拔与环境温度

- 当泵在环境温度大于40℃或海拔大于1000m时运行，电机输出功率P2会降低，所以泵在上述情况下，电机功率需配大。

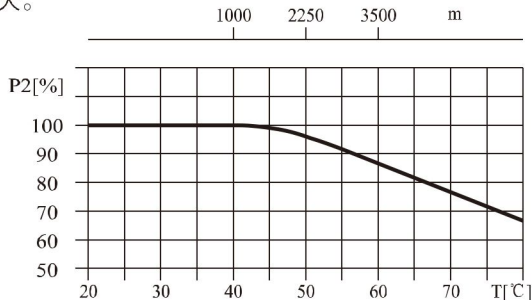

## 最大工作压力

- 下图表示压力和温度的极限，压力和温度须在所示范围内。

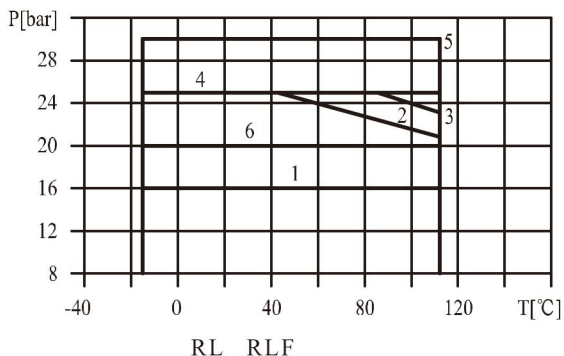

| 泵型号                      | 曲线号               |   |
|--------------------------|-------------------|---|
| RL, RLF 1/2/3/4/5        | 2                 |   |
| RL, RLF 8/10/12/15/16/20 | 3                 |   |
| RL, RLF 32               | 32-10-1~32-70     | 1 |
|                          | 32-80-2~32-120    | 4 |
|                          | 32-130-2~32-160   | 5 |
| RL, RLF 45               | 45-10-1~45-60     | 1 |
|                          | 45-70-2~45-90     | 4 |
|                          | 45-100-2~45-130-2 | 5 |
| RL, RLF 64               | 64-10-1~64-50     | 1 |
|                          | 64-60-2~64-80-1   | 4 |
| RL, RLF 90               | 90-10-1~90-50-2   | 1 |
|                          | 90-50~90-60       | 4 |
| RL, RLF 120/150/200      | 6                 |   |

注:曲线4/5需特殊订货

## 运行条件

- 稀薄、干净、非易燃易爆并不含固体颗粒或纤维的液体。
- 液体温度：常温型-15℃~+70℃  
热水型-15℃~+105℃
- 环境温度：最高+40℃
- 海拔：最高1000m

结构图 RL , RLF1、2、3、4、5

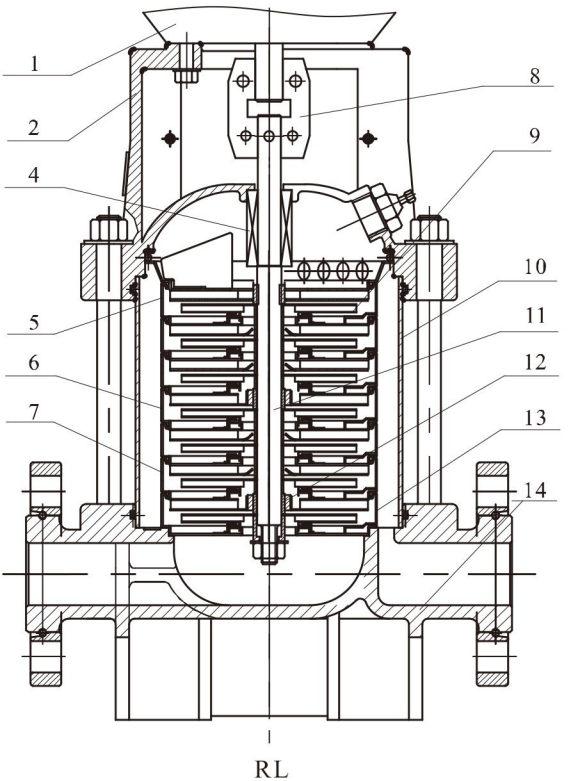
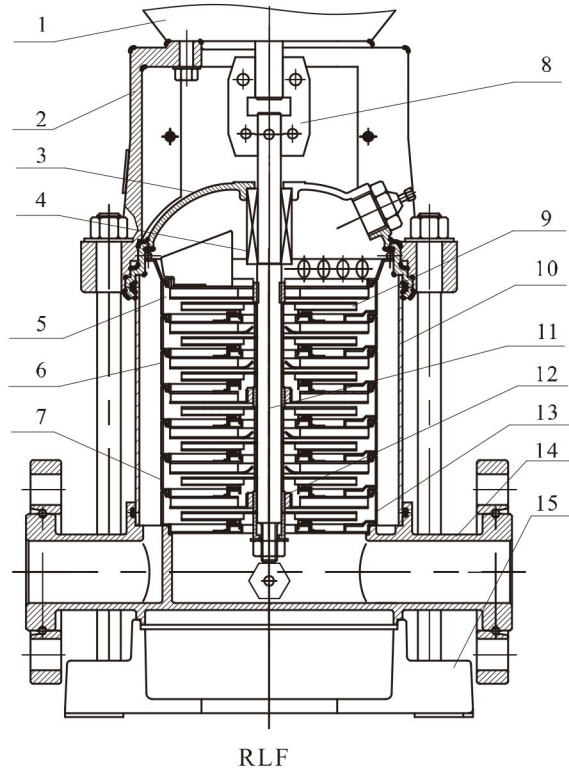

材料 RL , RLF1、2、3、4、5

| 序号  | 名称   | 材料      | AISI/ASTM               |
|-----|------|---------|-------------------------|
| 1   | 电机   | 组合件     |                         |
| 2   | 支架   | 铸铁/球墨铸铁 | ASTM25B<br>ASTM70-50-05 |
| 4   | 机械密封 | 组合件     |                         |
| 5   | 出水导叶 | 不锈钢     | AISI304                 |
| 6   | 导叶   | 不锈钢     | AISI304                 |
| 7   | 支撑导叶 | 不锈钢     | AISI304                 |
| 8   | 联轴器  | 球墨铸铁    | ASTM70-50-05            |
| 9   | 叶轮   | 不锈钢     | AISI304                 |
| 10  | 外筒   | 不锈钢     | AISI304                 |
| 11  | 泵轴   | 不锈钢     | AISI304<br>AISI316L     |
| 12  | 轴承   | 碳化钨     |                         |
| 13  | 进水导叶 | 不锈钢     | AISI304                 |
| RLF |      |         |                         |
| 3   | 密封座  | 不锈钢     | AISI304                 |
| 14  | 进出水体 | 不锈钢     | AISI304                 |
| 15  | 底座   | 铸铁      | ASTM25B                 |
| RL  |      |         |                         |
| 14  | 进出水体 | 铸铁      | ASTM25B                 |

## 结构图 RL , RLF8、10、12、15、16、20 材料 RL , RLF8、10、12、15、16、20

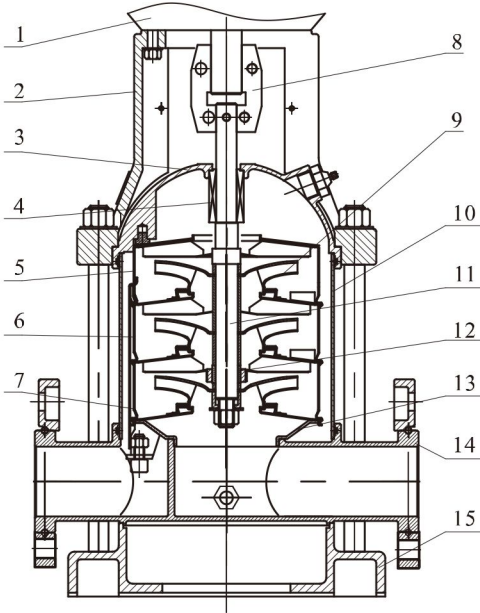

RLF

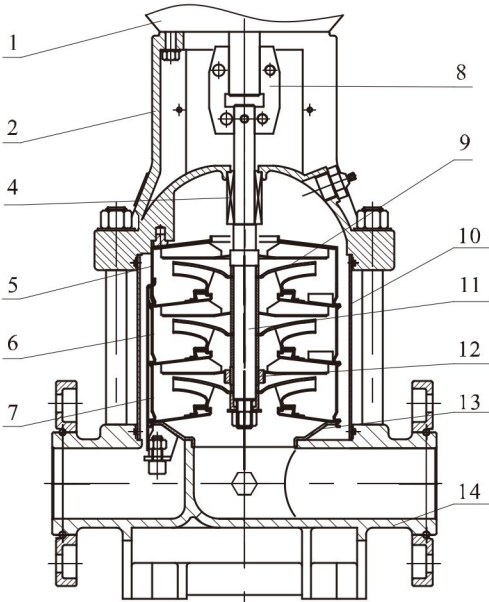

RL

| 序号  | 名称   | 材料      | AISI/ASTM               |
|-----|------|---------|-------------------------|
| 1   | 电机   | 组合件     |                         |
| 2   | 支架   | 铸铁/球墨铸铁 | ASTM25B<br>ASTM70-50-05 |
| 4   | 机械密封 | 组合件     |                         |
| 5   | 出水导叶 | 不锈钢     | AISI304                 |
| 6   | 导叶   | 不锈钢     | AISI304                 |
| 7   | 支撑导叶 | 不锈钢     | AISI304                 |
| 8   | 联轴器  | 球墨铸铁    | ASTM70-50-05            |
| 9   | 叶轮   | 不锈钢     | AISI304                 |
| 10  | 外筒   | 不锈钢     | AISI304                 |
| 11  | 泵轴   | 不锈钢     | AISI304<br>AISI316L     |
| 12  | 轴承   | 碳化钨     |                         |
| 13  | 进水导叶 | 不锈钢     | AISI304                 |
| RLF |      |         |                         |
| 3   | 密封座  | 不锈钢     | AISI304                 |
| 14  | 进出水体 | 不锈钢     | AISI304                 |
| 15  | 底座   | 铸铁      | ASTM25B                 |
| RL  |      |         |                         |
| 14  | 进出水体 | 铸铁      | ASTM25B                 |



## 结构图 RL , RLF 32、45、64、90

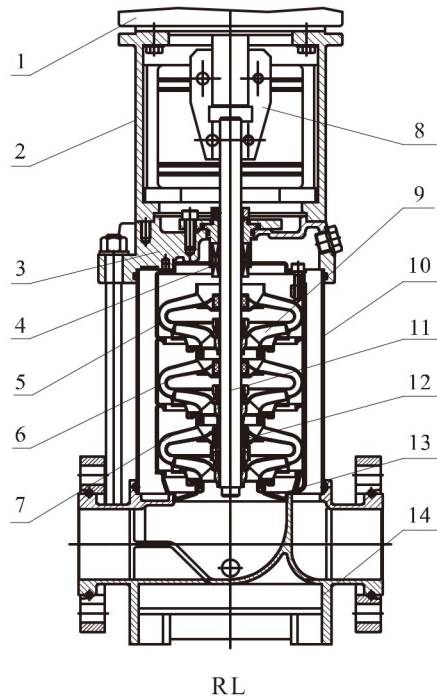
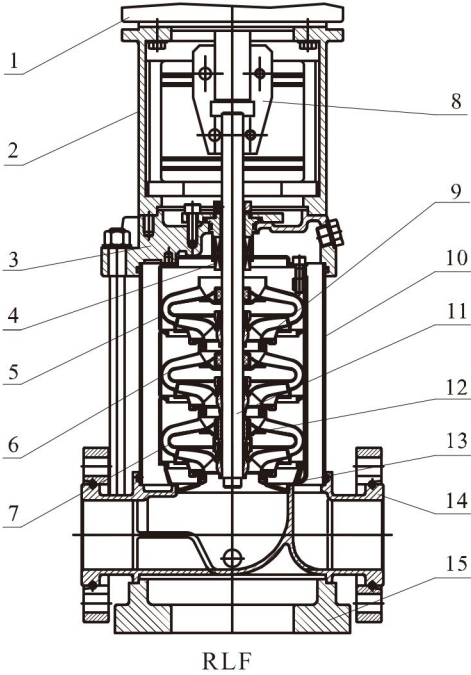

## 材料 RL , RLF 32、45、64、90

| 序号  | 名称   | 材料      | AISI/ASTM                      |
|-----|------|---------|--------------------------------|
| 1   | 电机   | 组合件     |                                |
| 2   | 支架   | 铸铁/球墨铸铁 | ASTM25B                        |
| 4   | 机械密封 | 组合件     |                                |
| 5   | 出水导叶 | 不锈钢     | AISI304                        |
| 6   | 导叶   | 不锈钢     | AISI304                        |
| 7   | 支撑导叶 | 不锈钢     | AISI304                        |
| 8   | 联轴器  | 球墨铸铁    | ASTM70-50-05                   |
| 9   | 叶轮   | 不锈钢     | AISI304                        |
| 10  | 外筒   | 不锈钢     | AISI304                        |
| 11  | 泵轴   | 不锈钢     | AISI304<br>AISI316L<br>AISI431 |
| 12  | 轴承   | 碳化钨     |                                |
| 13  | 进水导叶 | 不锈钢     | AISI304                        |
| RLF |      |         |                                |
| 3   | 密封座  | 不锈钢     | AISI304                        |
| 14  | 进出水体 | 不锈钢     | AISI304                        |
| 15  | 底座   | 铸铁      | ASTM25B                        |
| RL  |      |         |                                |
| 3   | 密封座  | 铸铁/球墨铸铁 | ASTM25B<br>ASTM70-50-05        |
| 14  | 进出水体 | 铸铁/球墨铸铁 | ASTM25B<br>ASTM70-50-05        |

## 结构图 RL , RLF120、150、200

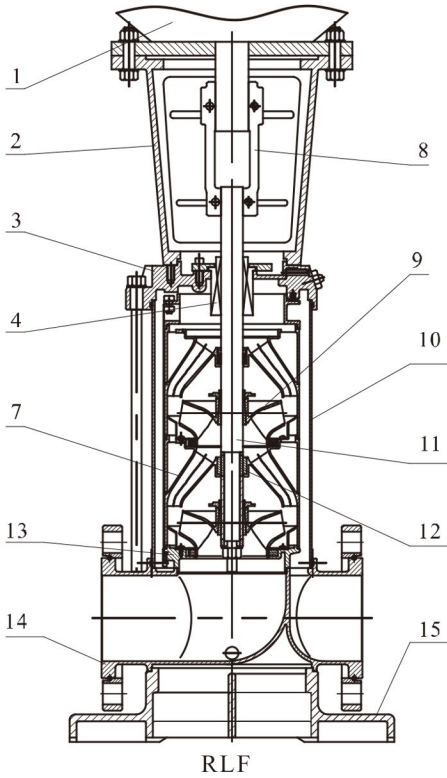

RLF

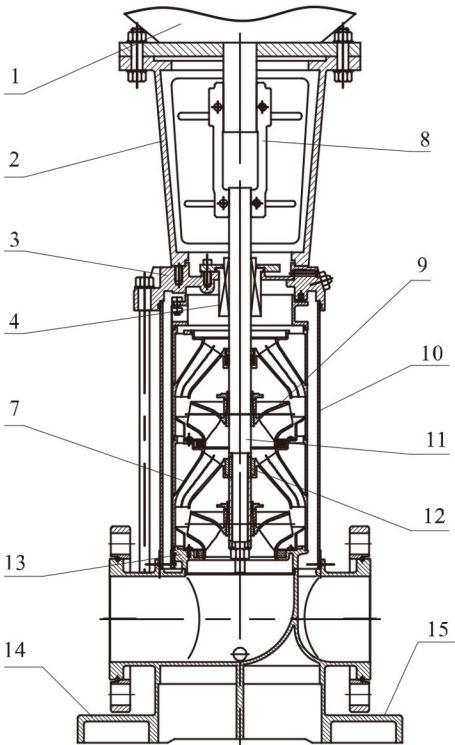

RL

## 材料RL , RLF 120、150、200

| 序号  | 名称   | 材料      | AISI/ASTM                      |
|-----|------|---------|--------------------------------|
| 1   | 电机   | 组合件     |                                |
| 2   | 支架   | 铸铁/球墨铸铁 | ASTM25B<br>ASTM70-50-05        |
| 4   | 机械密封 | 组合件     |                                |
| 7   | 支撑导叶 | 不锈钢     | AISI304                        |
| 8   | 联轴器  | 球墨铸铁    | ASTM7-50-05                    |
| 9   | 叶轮   | 不锈钢     | AISI304                        |
| 10  | 外筒   | 不锈钢     | AISI304                        |
| 11  | 泵轴   | 不锈钢     | AISI304<br>AISI316L<br>AISI431 |
| 12  | 轴承   | 碳化钨     |                                |
| 13  | 进水导叶 | 不锈钢     | AISI304                        |
| 15  | 底座   | 球墨铸铁    | ASTM70-50-05                   |
| RLF |      |         |                                |
| 3   | 密封座  | 不锈钢     | AISI304                        |
| 14  | 进出水体 | 不锈钢     | AISI304                        |
| RL  |      |         |                                |
| 3   | 密封座  | 球墨铸铁    | ASTM70-50-05                   |
| 14  | 进出水体 | 铸铁/球墨铸铁 | ASTM25B<br>ASTM7-50-05         |

## 最小进口压力 NPSH

如果泵中的压力低于输送液体的汽化压力，可能发生气蚀，为避免气蚀，确保泵进口侧有一最小压力，最大吸程 H[m]可按下式计算：

$$H = P_b \times 10.2 - NPSH - H_f - H_v - H_s$$

$P_b$  = 大气压力 [bar]

(大气压力可设定为 1 bar)

在闭式系统中， $P_b$  为系统压力 [bar]

NPSH = 净正吸头 [m]

(可从 NPSH 曲线上泵可能的最大流量处读取)

$H_f$  = 入口的管路损失 [m]

$H_v$  = 汽化压力 [m]

$H_s$  = 安全余量 = 最小 0.5 m 水头

如计算所得 H 为正值，泵可在最大吸程 H 情况下运行。

如计算所得 H 为负值，必须有一最小进口压力 H 的水头。

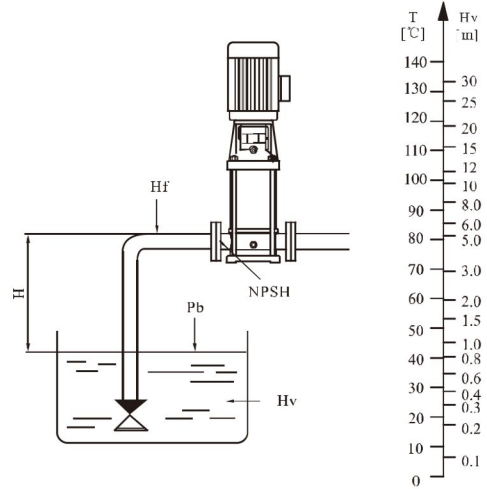

检查确保泵不会 / 没有处于气蚀状态

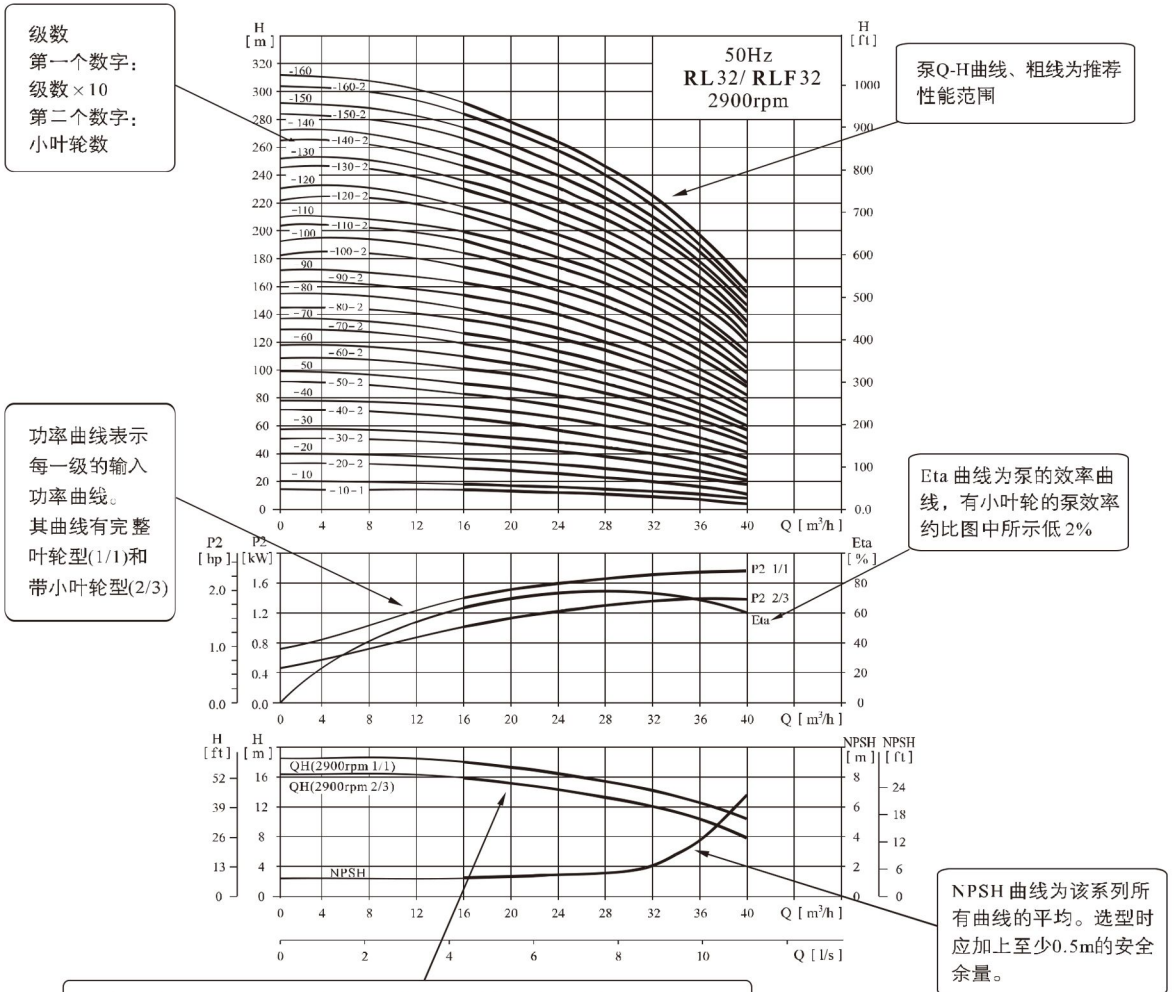

## 性能曲线

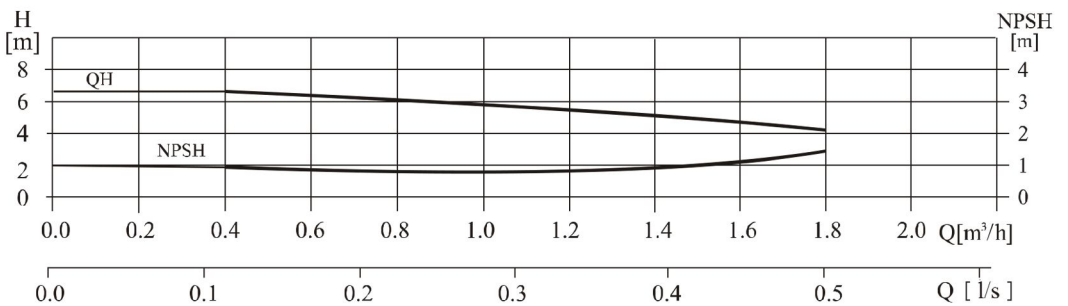
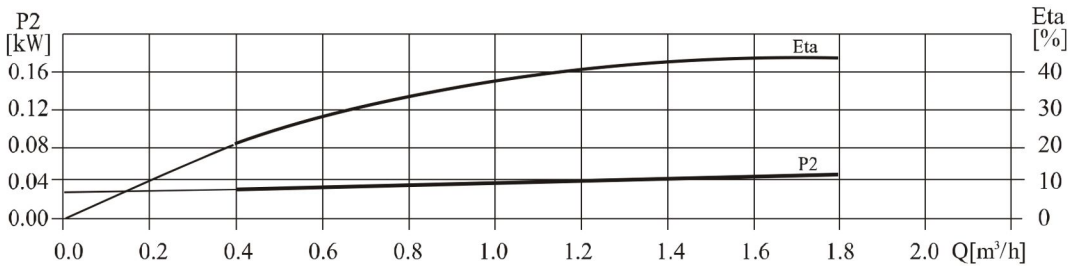
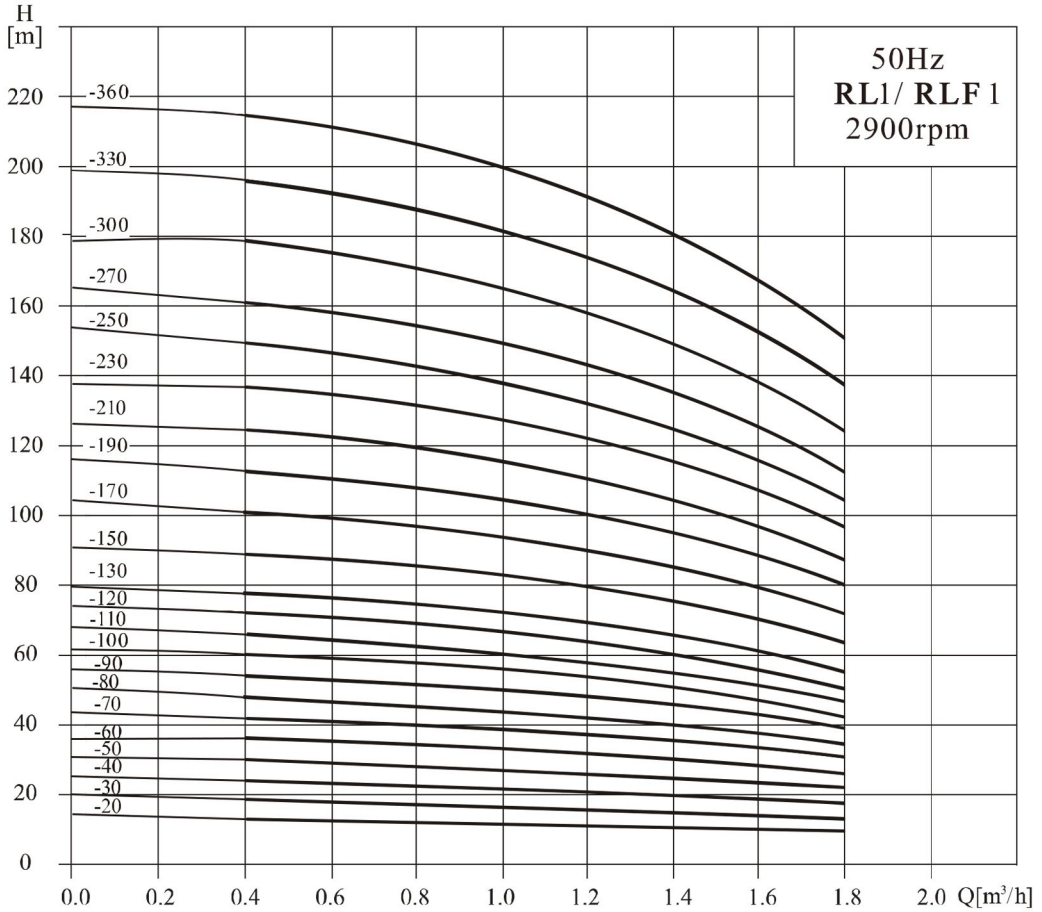

## 安装图

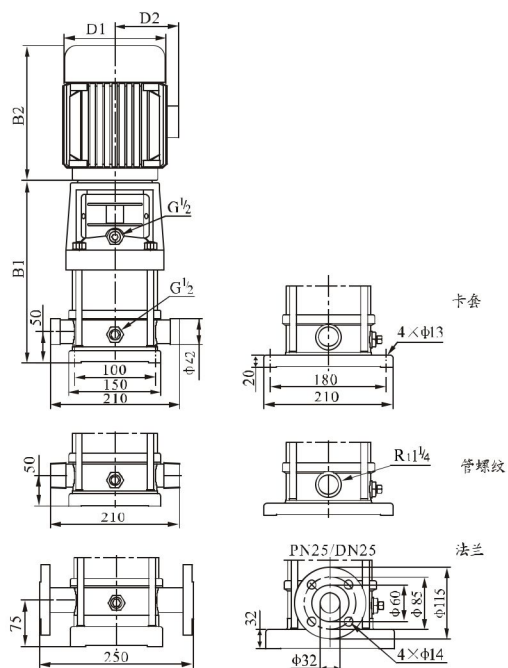

## 尺寸和重量

| 型号      | 尺寸(mm) |     |       |     |     | 重量(kg) |
|---------|--------|-----|-------|-----|-----|--------|
|         | B1     | B2  | B1+B2 | D1  | D2  |        |
| RL1-20  | 258    | 225 | 483   | 148 | 117 | 20     |
| RL1-30  | 276    | 225 | 501   | 148 | 117 | 20     |
| RL1-40  | 294    | 225 | 519   | 148 | 117 | 21     |
| RL1-50  | 312    | 225 | 537   | 148 | 117 | 21     |
| RL1-60  | 330    | 225 | 555   | 148 | 117 | 22     |
| RL1-70  | 348    | 225 | 573   | 148 | 117 | 23     |
| RL1-80  | 366    | 225 | 591   | 148 | 117 | 24     |
| RL1-90  | 384    | 225 | 609   | 148 | 117 | 25     |
| RL1-100 | 402    | 225 | 627   | 148 | 117 | 26     |
| RL1-110 | 420    | 225 | 645   | 148 | 117 | 26     |
| RL1-120 | 448    | 245 | 693   | 170 | 142 | 29     |
| RL1-130 | 466    | 245 | 711   | 170 | 142 | 30     |
| RL1-150 | 502    | 245 | 747   | 170 | 142 | 31     |
| RL1-170 | 538    | 245 | 783   | 170 | 142 | 33     |
| RL1-190 | 574    | 245 | 819   | 170 | 142 | 34     |
| RL1-210 | 610    | 245 | 855   | 170 | 142 | 35     |
| RL1-230 | 646    | 245 | 891   | 170 | 142 | 36     |
| RL1-250 | 692    | 290 | 982   | 190 | 155 | 42     |
| RL1-270 | 728    | 290 | 1018  | 190 | 155 | 43     |
| RL1-300 | 782    | 290 | 1072  | 190 | 155 | 45     |
| RL1-330 | 836    | 290 | 1126  | 190 | 155 | 49     |
| RL1-360 | 890    | 290 | 1180  | 190 | 155 | 51     |

## 性能表

| 型号       | 配用电机<br>(kW) | Q<br>(m <sup>3</sup> /h) | 0.4 | 0.6  | 0.8  | 1.0  | 1.2  | 1.4  | 1.6 | 1.8 |
|----------|--------------|--------------------------|-----|------|------|------|------|------|-----|-----|
| RL 1-20  | 0.37         | II<br>(m)                | 13  | 12.5 | 12   | 11.5 | 11   | 10.5 | 10  | 9.5 |
| RL 1-30  | 0.37         |                          | 19  | 18   | 17.5 | 17   | 16.5 | 16   | 15  | 14  |
| RL 1-40  | 0.37         |                          | 24  | 23.5 | 23   | 22.5 | 21.5 | 21   | 19  | 18  |
| RL 1-50  | 0.37         |                          | 30  | 29.6 | 29   | 28   | 27   | 26   | 24  | 22  |
| RL 1-60  | 0.37         |                          | 36  | 35.5 | 35   | 33.5 | 33   | 31   | 28  | 26  |
| RL 1-70  | 0.37         |                          | 42  | 41   | 40.5 | 39   | 38   | 36   | 33  | 30  |
| RL 1-80  | 0.55         |                          | 48  | 47   | 46   | 45   | 43   | 41   | 38  | 34  |
| RL 1-90  | 0.55         |                          | 54  | 53   | 52   | 51   | 49   | 46   | 43  | 39  |
| RL 1-100 | 0.55         |                          | 60  | 59   | 58   | 57   | 54   | 51   | 48  | 43  |
| RL 1-110 | 0.55         |                          | 66  | 65   | 63   | 61   | 59   | 56   | 52  | 47  |
| RL 1-120 | 0.75         |                          | 72  | 71   | 69   | 67   | 64   | 61   | 57  | 51  |
| RL 1-130 | 0.75         |                          | 78  | 77   | 75   | 73   | 69   | 66   | 62  | 55  |
| RL 1-150 | 0.75         |                          | 89  | 88   | 86   | 84   | 79   | 76   | 71  | 63  |
| RL 1-170 | 1.1          |                          | 101 | 99   | 97   | 95   | 89   | 86   | 80  | 71  |
| RL 1-190 | 1.1          |                          | 113 | 110  | 108  | 106  | 99   | 96   | 89  | 79  |
| RL 1-210 | 1.1          |                          | 124 | 122  | 120  | 117  | 110  | 106  | 98  | 87  |
| RL 1-230 | 1.1          |                          | 137 | 133  | 131  | 128  | 121  | 116  | 107 | 96  |
| RL 1-250 | 1.5          |                          | 149 | 145  | 143  | 139  | 131  | 126  | 116 | 104 |
| RL 1-270 | 1.5          | 161                      | 157 | 155  | 150  | 141  | 136  | 125  | 112 |     |
| RL 1-300 | 1.5          | 178                      | 175 | 171  | 166  | 157  | 150  | 139  | 124 |     |
| RL 1-330 | 2.2          | 196                      | 192 | 188  | 183  | 173  | 165  | 154  | 137 |     |
| RL 1-360 | 2.2          | 214                      | 210 | 205  | 200  | 190  | 181  | 169  | 151 |     |

单相电机、隔爆电机外形尺寸有所变动，详情请咨询本公司。

## 性能曲线

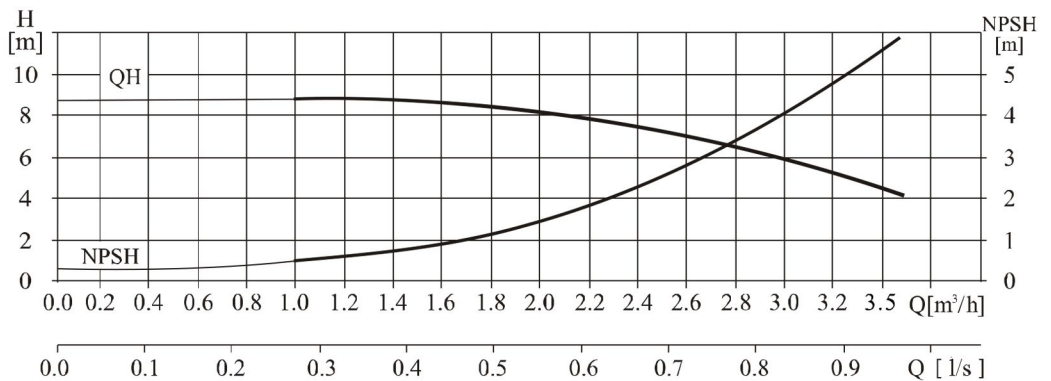
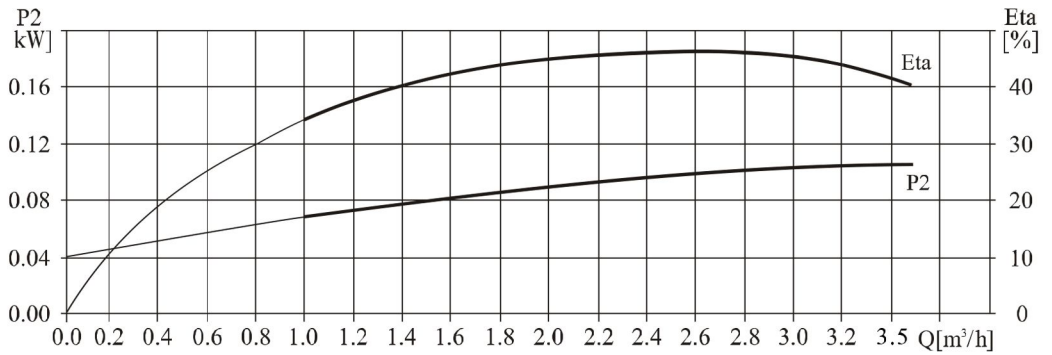
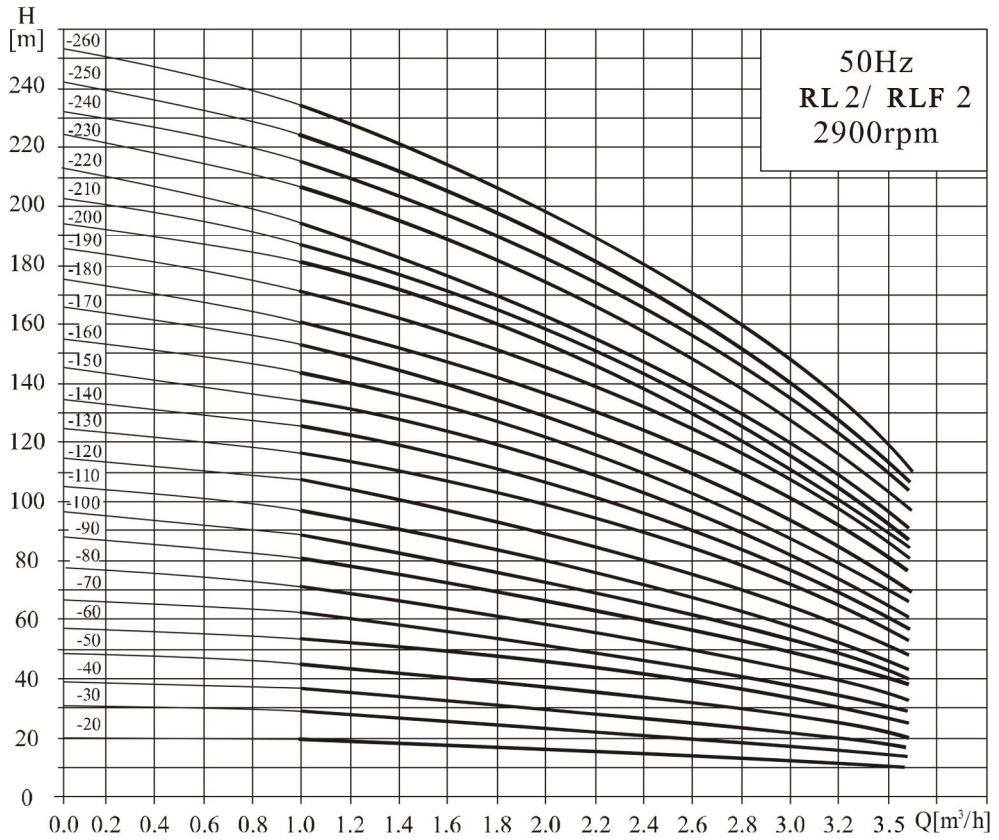

## 安装图

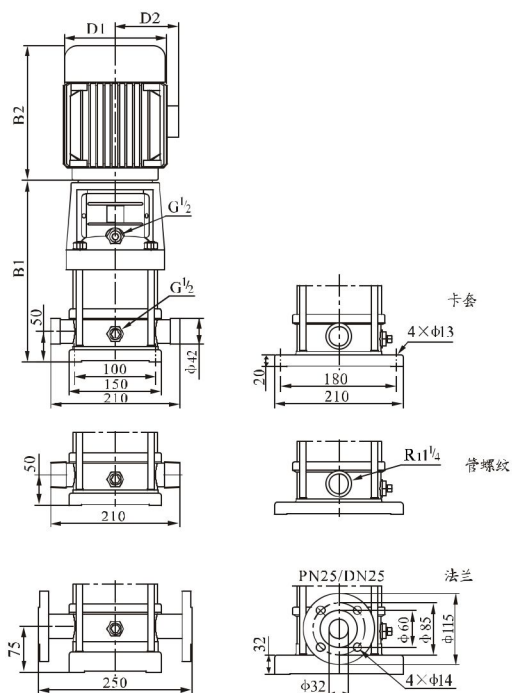

## 尺寸和重量

| 型号       | 尺寸(mm) |     |       |     |     | 重量(kg) |
|----------|--------|-----|-------|-----|-----|--------|
|          | B1     | B2  | B1+B2 | D1  | D2  |        |
| RL 2-20  | 258    | 225 | 483   | 148 | 117 | 20     |
| RL 2-30  | 276    | 225 | 501   | 148 | 117 | 20     |
| RL 2-40  | 294    | 225 | 519   | 148 | 117 | 22     |
| RL 2-50  | 312    | 225 | 537   | 148 | 117 | 23     |
| RL 2-60  | 340    | 245 | 585   | 170 | 142 | 26     |
| RL 2-70  | 358    | 245 | 603   | 170 | 142 | 26     |
| RL 2-90  | 394    | 245 | 639   | 170 | 142 | 28     |
| RL 2-110 | 430    | 245 | 675   | 170 | 142 | 29     |
| RL 2-130 | 476    | 290 | 766   | 190 | 155 | 35     |
| RL 2-150 | 512    | 290 | 802   | 190 | 155 | 36     |
| RL 2-180 | 566    | 290 | 856   | 190 | 155 | 41     |
| RL 2-220 | 638    | 290 | 928   | 190 | 155 | 42     |
| RL 2-260 | 720    | 345 | 1065  | 197 | 165 | 52     |

## 性能表

| 型号       | 配用电机<br>(kW) | Q<br>(m <sup>3</sup> /h) | 1   | 1.2 | 1.6 | 2.0 | 2.4 | 2.8 | 3.2 | 3.5 |
|----------|--------------|--------------------------|-----|-----|-----|-----|-----|-----|-----|-----|
| RL 2-20  | 0.37         | H<br>(m)                 | 18  | 17  | 16  | 15  | 13  | 12  | 10  | 8   |
| RL 2-30  | 0.37         |                          | 27  | 26  | 24  | 22  | 20  | 18  | 15  | 12  |
| RL 2-40  | 0.55         |                          | 36  | 35  | 33  | 30  | 26  | 24  | 20  | 16  |
| RL 2-50  | 0.55         |                          | 45  | 43  | 40  | 37  | 33  | 30  | 24  | 20  |
| RL 2-60  | 0.75         |                          | 53  | 52  | 50  | 45  | 40  | 36  | 30  | 24  |
| RL 2-70  | 0.75         |                          | 63  | 61  | 57  | 52  | 47  | 41  | 35  | 28  |
| RL 2-90  | 1.1          |                          | 80  | 78  | 73  | 67  | 61  | 54  | 45  | 37  |
| RL 2-110 | 1.1          |                          | 98  | 95  | 89  | 82  | 73  | 64  | 54  | 44  |
| RL 2-130 | 1.5          |                          | 116 | 114 | 106 | 98  | 89  | 78  | 65  | 52  |
| RL 2-150 | 1.5          |                          | 134 | 130 | 123 | 112 | 100 | 90  | 73  | 60  |
| RL 2-180 | 2.2          |                          | 161 | 157 | 148 | 136 | 121 | 108 | 91  | 76  |
| RL 2-220 | 2.2          |                          | 197 | 192 | 180 | 165 | 148 | 130 | 110 | 90  |
| RL 2-260 | 3.0          |                          | 232 | 228 | 214 | 198 | 179 | 158 | 130 | 110 |

单相电机、隔爆电机外形尺寸有所变动，详情请咨询本公司。

## 性能曲线

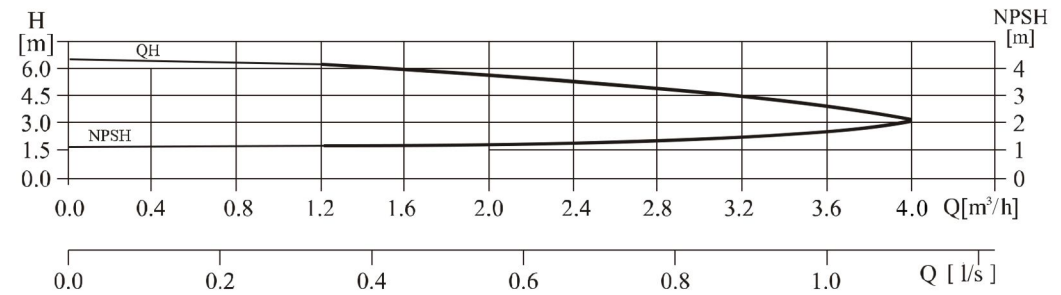
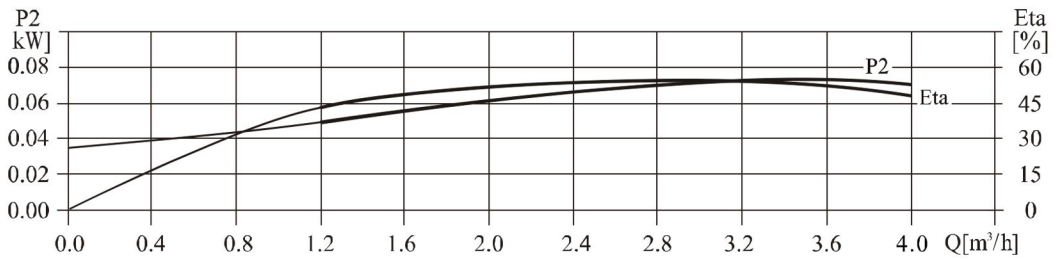
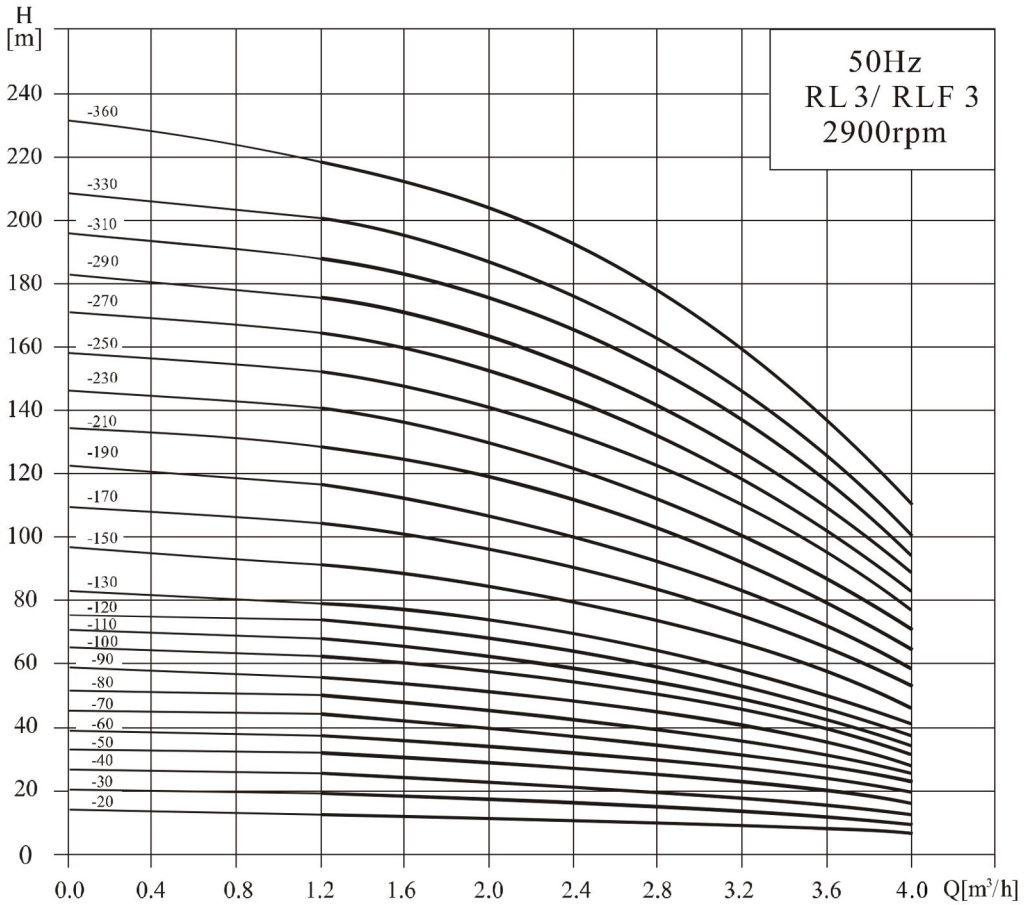



## 安装图

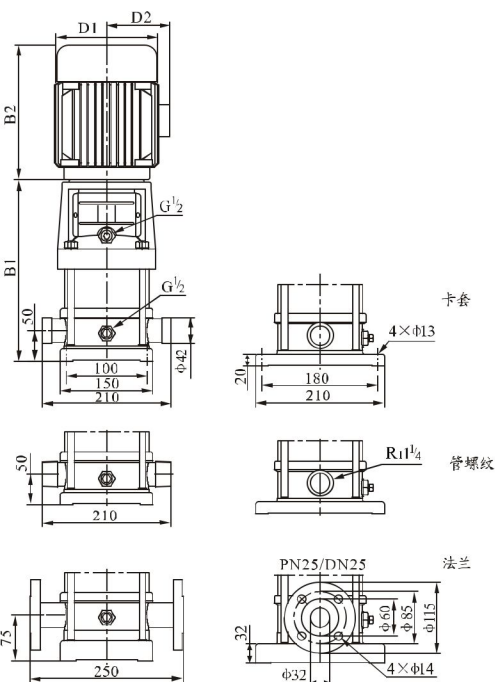

## 尺寸和重量

| 型号       | 尺寸(mm) |     |       |     |     | 重量(kg) |
|----------|--------|-----|-------|-----|-----|--------|
|          | B1     | B2  | B1+B2 | D1  | D2  |        |
| RL 3-20  | 258    | 225 | 483   | 148 | 117 | 20     |
| RL 3-30  | 276    | 225 | 501   | 148 | 117 | 20     |
| RL 3-40  | 294    | 225 | 519   | 148 | 117 | 21     |
| RL 3-50  | 312    | 225 | 537   | 148 | 117 | 21     |
| RL 3-60  | 330    | 225 | 555   | 148 | 117 | 23     |
| RL 3-70  | 348    | 225 | 573   | 148 | 117 | 24     |
| RL 3-80  | 376    | 245 | 621   | 170 | 142 | 27     |
| RL 3-90  | 394    | 245 | 639   | 170 | 142 | 28     |
| RL 3-100 | 412    | 245 | 657   | 170 | 142 | 28     |
| RL 3-110 | 430    | 245 | 675   | 170 | 142 | 29     |
| RL 3-120 | 448    | 245 | 693   | 170 | 142 | 30     |
| RL 3-130 | 466    | 245 | 711   | 170 | 142 | 31     |
| RL 3-150 | 502    | 245 | 747   | 170 | 142 | 32     |
| RL 3-170 | 548    | 290 | 838   | 190 | 155 | 38     |
| RL 3-190 | 584    | 290 | 874   | 190 | 155 | 39     |
| RL 3-210 | 620    | 290 | 910   | 190 | 155 | 42     |
| RL 3-230 | 656    | 290 | 946   | 190 | 155 | 43     |
| RL 3-250 | 692    | 290 | 982   | 190 | 155 | 44     |
| RL 3-270 | 728    | 290 | 1018  | 190 | 155 | 45     |
| RL 3-290 | 764    | 290 | 1054  | 190 | 155 | 46     |
| RL 3-310 | 810    | 345 | 1155  | 197 | 165 | 54     |
| RL 3-330 | 846    | 345 | 1191  | 197 | 165 | 55     |
| RL 3-360 | 900    | 345 | 1245  | 197 | 165 | 57     |

## 性能表

| 型号      | 配用电动机(kW) | Q (m <sup>3</sup> /h) | 1.2  | 1.6  | 2.0  | 2.4  | 2.8 | 3.0 | 3.2 | 3.6 | 4.0 |
|---------|-----------|-----------------------|------|------|------|------|-----|-----|-----|-----|-----|
| RL3-20  | 0.37      | H (m)                 | 12.5 | 11.5 | 11   | 10.5 | 10  | 9   | 8   | 7   | 6   |
| RL3-30  | 0.37      |                       | 19   | 18.5 | 17.5 | 16.5 | 15  | 14  | 13  | 11  | 9   |
| RL3-40  | 0.37      |                       | 25   | 24   | 23   | 21.5 | 20  | 19  | 18  | 15  | 12  |
| RL3-50  | 0.37      |                       | 31   | 30   | 29   | 27   | 25  | 23  | 22  | 19  | 16  |
| RL3-60  | 0.55      |                       | 36   | 35   | 34   | 32   | 30  | 28  | 27  | 23  | 19  |
| RL3-70  | 0.55      |                       | 43   | 41   | 39   | 37   | 34  | 32  | 31  | 27  | 22  |
| RL3-80  | 0.75      |                       | 49   | 47   | 45   | 43   | 39  | 37  | 35  | 31  | 25  |
| RL3-90  | 0.75      |                       | 55   | 53   | 51   | 48   | 45  | 42  | 40  | 35  | 28  |
| RL3-100 | 0.75      |                       | 61   | 59   | 57   | 54   | 50  | 47  | 45  | 39  | 31  |
| RL3-110 | 1.1       |                       | 67   | 64   | 61   | 58   | 54  | 51  | 49  | 42  | 34  |
| RL3-120 | 1.1       |                       | 73   | 70   | 67   | 63   | 58  | 55  | 52  | 45  | 37  |
| RL3-130 | 1.1       |                       | 78   | 76   | 73   | 69   | 64  | 60  | 57  | 49  | 40  |
| RL3-150 | 1.1       |                       | 90   | 88   | 84   | 79   | 73  | 69  | 66  | 57  | 46  |
| RL3-170 | 1.5       |                       | 103  | 100  | 96   | 90   | 83  | 79  | 75  | 64  | 52  |
| RL3-190 | 1.5       |                       | 115  | 112  | 107  | 100  | 92  | 88  | 83  | 72  | 58  |
| RL3-210 | 2.2       |                       | 128  | 124  | 119  | 112  | 102 | 98  | 91  | 79  | 64  |
| RL3-230 | 2.2       | 140                   | 135  | 130  | 122  | 112  | 107 | 100 | 86  | 70  |     |
| RL3-250 | 2.2       | 151                   | 147  | 141  | 131  | 122  | 116 | 109 | 94  | 76  |     |
| RL3-270 | 2.2       | 164                   | 159  | 152  | 143  | 132  | 124 | 117 | 101 | 82  |     |
| RL3-290 | 2.2       | 175                   | 170  | 163  | 153  | 142  | 133 | 126 | 109 | 88  |     |
| RL3-310 | 3.0       | 187                   | 182  | 175  | 165  | 153  | 142 | 135 | 116 | 94  |     |
| RL3-330 | 3.0       | 199                   | 194  | 187  | 176  | 163  | 151 | 145 | 125 | 100 |     |
| RL3-360 | 3.0       | 218                   | 212  | 204  | 192  | 178  | 168 | 159 | 137 | 109 |     |

单相电机、隔爆电机外形尺寸有所变动，详情请咨询本公司。

## 性能曲线

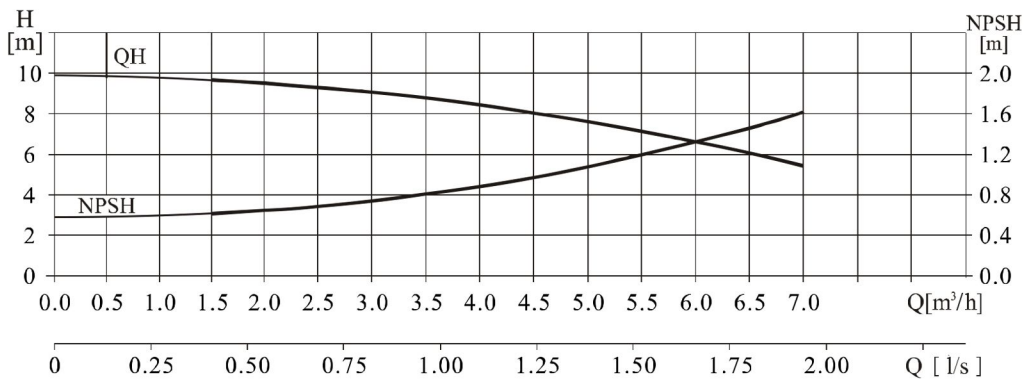
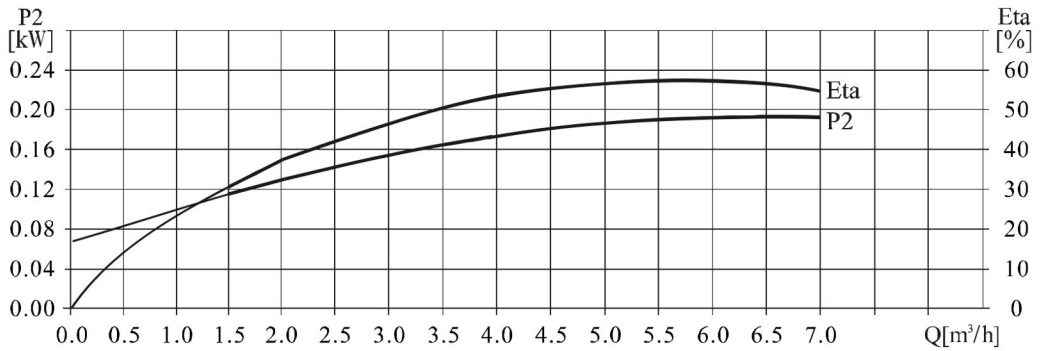
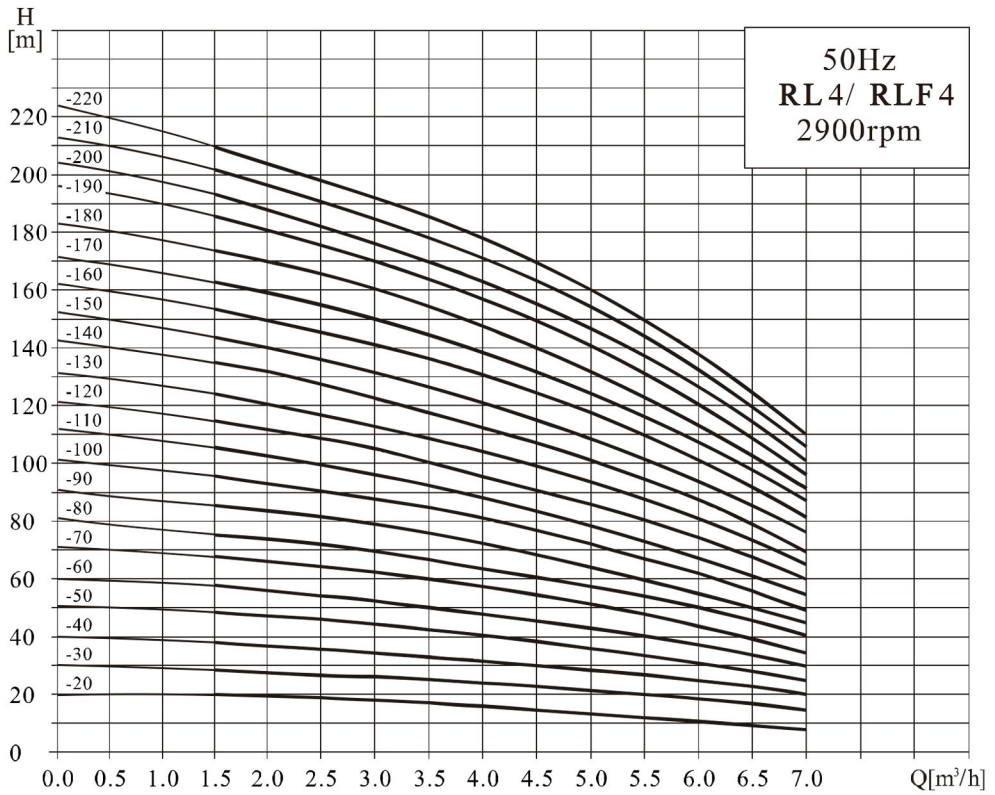

## 安装图

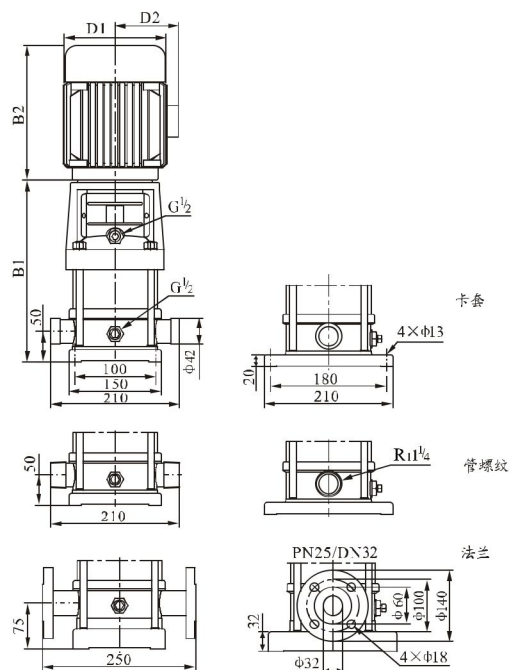

## 尺寸和重量

| 型号       | 尺寸(mm) |     |       |     |     | 重量(kg) |
|----------|--------|-----|-------|-----|-----|--------|
|          | B1     | B2  | B1+B2 | D1  | D2  |        |
| RL 4-20  | 276    | 225 | 501   | 148 | 117 | 21     |
| RL 4-30  | 303    | 225 | 528   | 148 | 117 | 22     |
| RL 4-40  | 340    | 245 | 585   | 170 | 142 | 25     |
| RL 4-50  | 367    | 245 | 612   | 170 | 142 | 27     |
| RL 4-60  | 394    | 245 | 639   | 170 | 142 | 27     |
| RL 4-70  | 431    | 290 | 721   | 190 | 155 | 33     |
| RL 4-80  | 458    | 290 | 748   | 190 | 155 | 33     |
| RL 4-100 | 512    | 290 | 802   | 190 | 155 | 37     |
| RL 4-120 | 566    | 290 | 856   | 190 | 155 | 38     |
| RL 4-140 | 630    | 345 | 975   | 197 | 165 | 46     |
| RL 4-160 | 684    | 345 | 1029  | 197 | 165 | 48     |
| RL 4-190 | 765    | 355 | 1120  | 230 | 188 | 57     |
| RL 4-220 | 846    | 355 | 1201  | 230 | 188 | 59     |

## 性能表

| 型号       | 配用电机<br>(kW) | Q<br>(m <sup>3</sup> /h) | H (m) |     |     |     |     |     |     |
|----------|--------------|--------------------------|-------|-----|-----|-----|-----|-----|-----|
|          |              |                          | 1.5   | 2.0 | 3.0 | 4.0 | 5.0 | 6.0 | 7.0 |
| RL 4-20  | 0.37         | H (m)                    | 19    | 18  | 17  | 15  | 13  | 10  | 8   |
| RL 4-30  | 0.55         |                          | 28    | 27  | 26  | 24  | 20  | 18  | 13  |
| RL 4-40  | 0.75         |                          | 38    | 36  | 34  | 32  | 27  | 24  | 19  |
| RL 4-50  | 1.1          |                          | 47    | 45  | 43  | 40  | 34  | 31  | 23  |
| RL 4-60  | 1.1          |                          | 56    | 54  | 52  | 48  | 41  | 37  | 28  |
| RL 4-70  | 1.5          |                          | 66    | 63  | 61  | 56  | 48  | 43  | 33  |
| RL 4-80  | 1.5          |                          | 74    | 72  | 70  | 64  | 55  | 50  | 38  |
| RL 4-100 | 2.2          |                          | 96    | 90  | 87  | 81  | 71  | 62  | 48  |
| RL 4-120 | 2.2          |                          | 114   | 108 | 104 | 95  | 85  | 75  | 58  |
| RL 4-140 | 3.0          |                          | 136   | 126 | 122 | 112 | 101 | 89  | 68  |
| RL 4-160 | 3.0          |                          | 152   | 144 | 140 | 129 | 115 | 101 | 78  |
| RL 4-190 | 4.0          |                          | 183   | 171 | 168 | 153 | 137 | 122 | 93  |
| RL 4-220 | 4.0          |                          | 211   | 200 | 192 | 178 | 160 | 138 | 108 |

单相电机、隔爆电机外形尺寸有所变动，详情请咨询本公司。

## 性能曲线

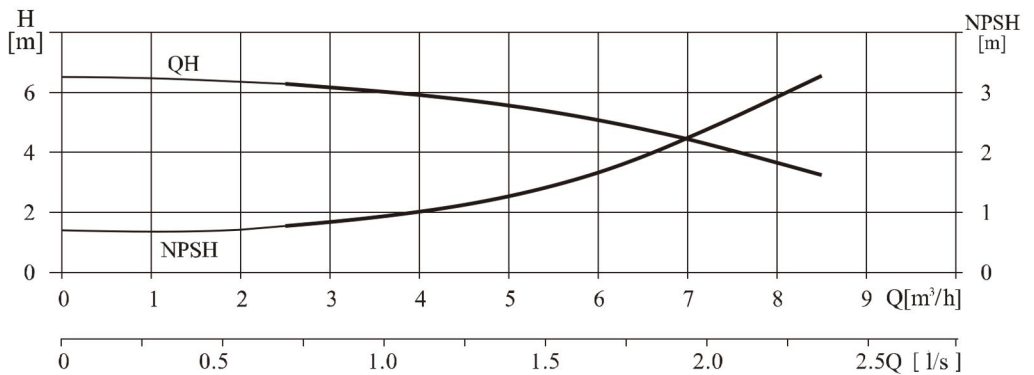
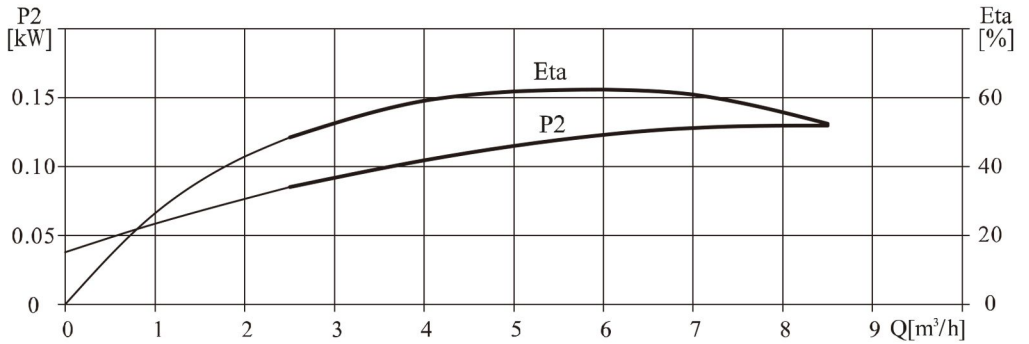
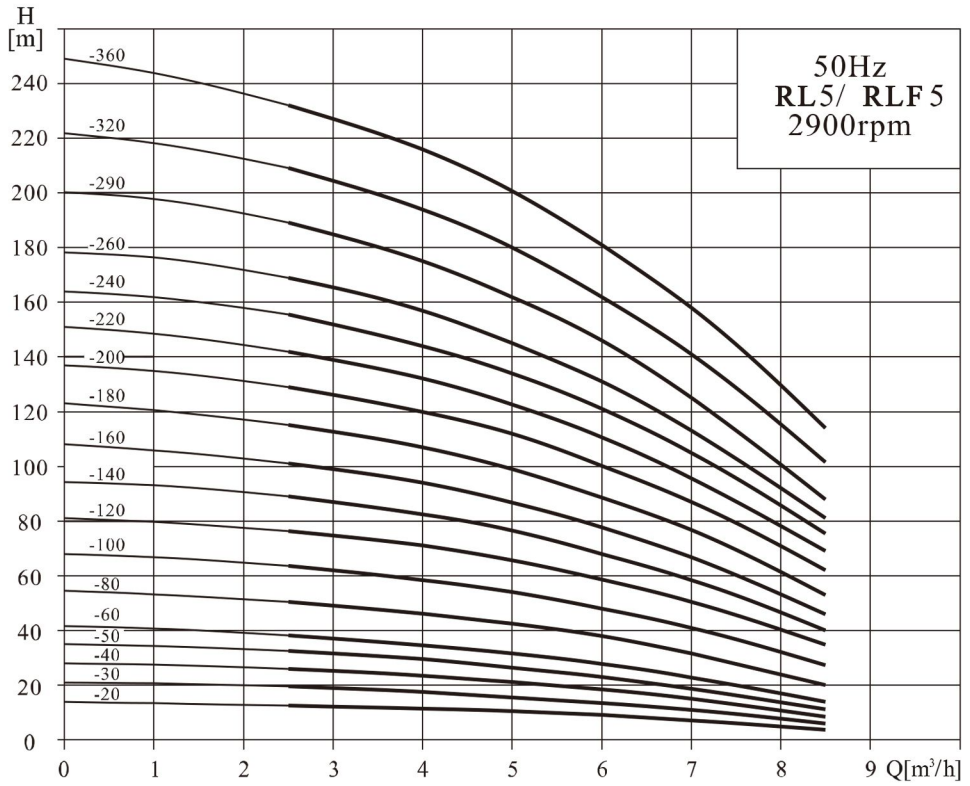

## 安装图

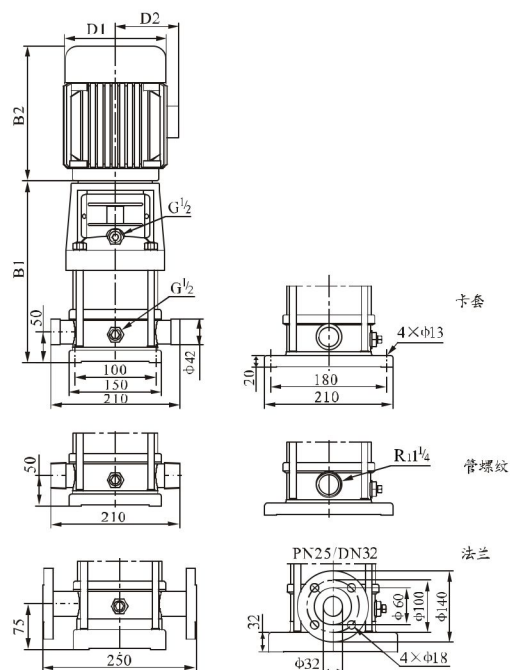

## 尺寸和重量

| 型号       | 尺寸(mm) |     |       |     |     | 重量(kg) |
|----------|--------|-----|-------|-----|-----|--------|
|          | B1     | B2  | B1+B2 | D1  | D2  |        |
| RL 5-20  | 276    | 225 | 501   | 148 | 117 | 21     |
| RL 5-30  | 303    | 225 | 528   | 148 | 117 | 22     |
| RL 5-40  | 330    | 225 | 555   | 148 | 117 | 23     |
| RL 5-50  | 367    | 245 | 612   | 170 | 142 | 25     |
| RL 5-60  | 394    | 245 | 639   | 170 | 142 | 26     |
| RL 5-80  | 448    | 245 | 693   | 170 | 142 | 27     |
| RL 5-100 | 512    | 290 | 802   | 190 | 155 | 33     |
| RL 5-120 | 566    | 290 | 856   | 190 | 155 | 37     |
| RL 5-140 | 620    | 290 | 910   | 190 | 155 | 38     |
| RL 5-160 | 674    | 290 | 964   | 190 | 155 | 39     |
| RL 5-180 | 738    | 345 | 1083  | 197 | 165 | 48     |
| RL 5-200 | 792    | 345 | 1137  | 197 | 165 | 49     |
| RL 5-220 | 846    | 355 | 1201  | 230 | 185 | 57     |
| RL 5-240 | 900    | 355 | 1255  | 230 | 185 | 58     |
| RL 5-260 | 954    | 355 | 1309  | 230 | 185 | 59     |
| RL 5-290 | 1035   | 355 | 1390  | 230 | 185 | 60     |
| RL 5-320 | 1136   | 390 | 1526  | 260 | 210 | 75     |
| RL 5-360 | 1244   | 390 | 1634  | 260 | 210 | 76     |

## 性能表

| 型号       | 配用电机<br>(kW) | Q<br>(m <sup>3</sup> /h) | 2.5      | 4    | 5    | 6    | 7    | 8.5  |
|----------|--------------|--------------------------|----------|------|------|------|------|------|
|          |              |                          | H<br>(m) |      |      |      |      |      |
| RL 5-20  | 0.37         |                          | 12.5     | 11.5 | 10.5 | 9    | 7    | 3.5  |
| RL 5-30  | 0.55         |                          | 19.5     | 17.5 | 15.5 | 13.5 | 11   | 6    |
| RL 5-40  | 0.55         |                          | 26       | 23.5 | 21   | 18.5 | 15   | 8.5  |
| RL 5-50  | 0.75         |                          | 32.5     | 29.5 | 26.5 | 23   | 18.5 | 11   |
| RL 5-60  | 1.1          |                          | 38.5     | 34.5 | 31.5 | 28   | 23   | 14   |
| RL 5-80  | 1.1          |                          | 50.5     | 46   | 42.5 | 38   | 31.5 | 20   |
| RL 5-100 | 1.5          |                          | 63.5     | 58.5 | 54   | 48   | 41   | 27.5 |
| RL 5-120 | 2.2          |                          | 76       | 71   | 65.5 | 58.5 | 50.5 | 35   |
| RL 5-140 | 2.2          |                          | 89       | 82   | 76.5 | 68   | 58.5 | 40   |
| RL 5-160 | 2.2          |                          | 101      | 94   | 87   | 77.5 | 66.5 | 46   |
| RL 5-180 | 3.0          |                          | 115      | 107  | 99   | 88.5 | 77   | 53   |
| RL 5-200 | 3.0          |                          | 129      | 120  | 112  | 100  | 87   | 62   |
| RL 5-220 | 4.0          |                          | 142      | 132  | 123  | 111  | 96   | 69   |
| RL 5-240 | 4.0          |                          | 156      | 144  | 134  | 121  | 105  | 75.5 |
| RL 5-260 | 4.0          |                          | 169      | 157  | 145  | 131  | 113  | 81   |
| RL 5-290 | 4.0          |                          | 189      | 175  | 162  | 146  | 125  | 88   |
| RL 5-320 | 5.5          |                          | 209      | 194  | 180  | 162  | 141  | 102  |
| RL 5-360 | 5.5          |                          | 232      | 216  | 201  | 181  | 158  | 114  |

单相电机、隔爆电机外形尺寸有所变动，详情请咨询本公司。

## 性能曲线

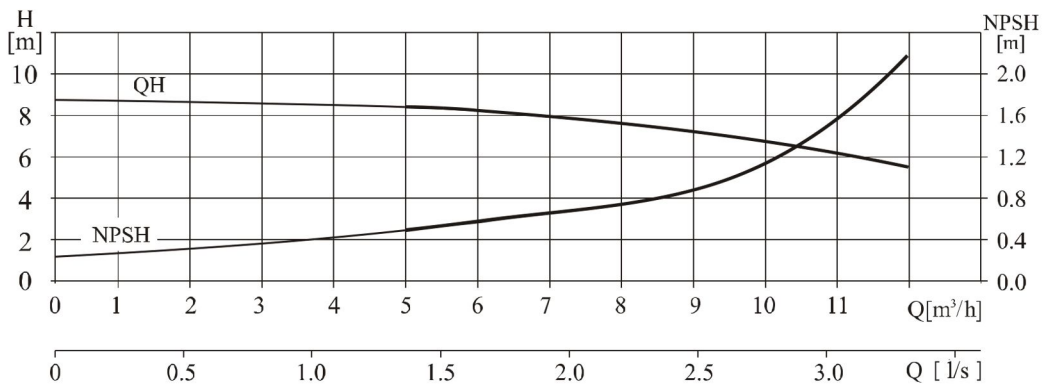
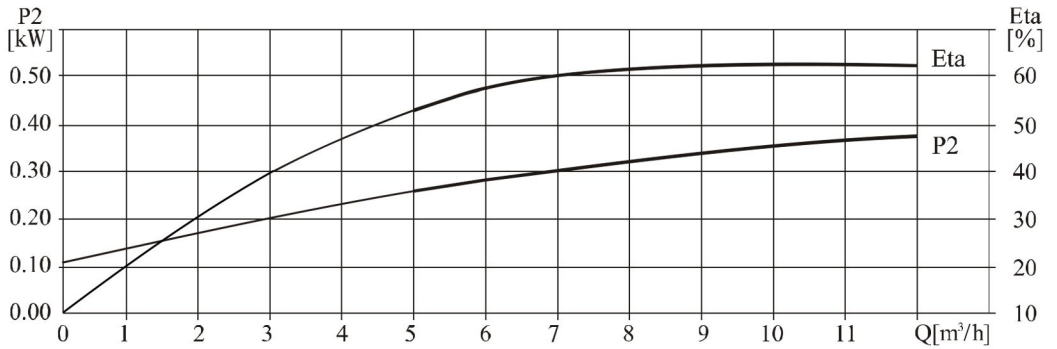
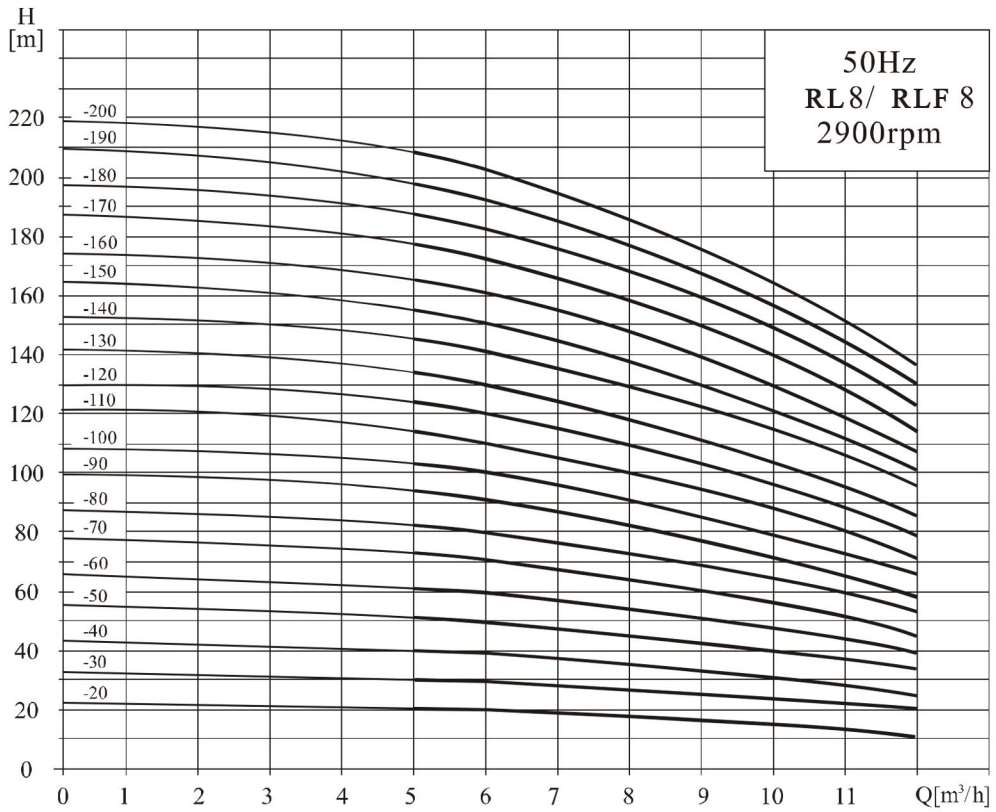

## 安装图

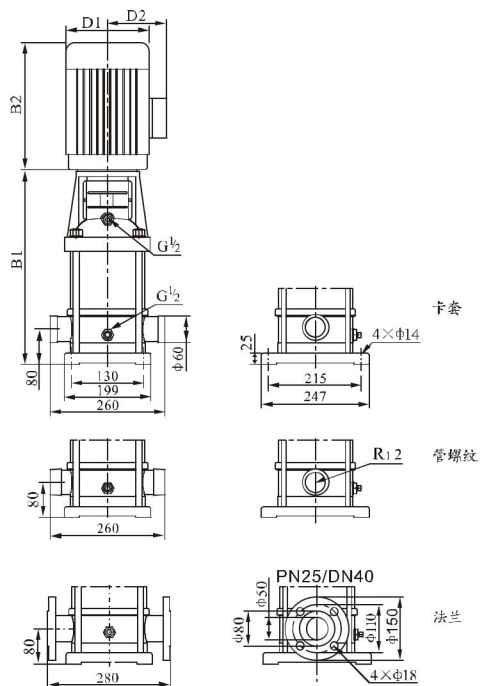

## 尺寸和重量

| 型号      | 尺寸(mm) |     |       |     |     | 重量(kg) |
|---------|--------|-----|-------|-----|-----|--------|
|         | B1     | B2  | B1+B2 | D1  | D2  |        |
| RL8-20  | 347    | 245 | 592   | 170 | 142 | 32     |
| RL8-30  | 377    | 245 | 622   | 170 | 142 | 34     |
| RL8-40  | 417    | 290 | 707   | 190 | 155 | 40     |
| RL8-50  | 447    | 290 | 737   | 190 | 155 | 44     |
| RL8-60  | 477    | 290 | 767   | 190 | 155 | 45     |
| RL8-80  | 547    | 345 | 892   | 197 | 165 | 53     |
| RL8-100 | 607    | 355 | 962   | 230 | 188 | 64     |
| RL8-120 | 667    | 355 | 1022  | 230 | 188 | 66     |
| RL8-140 | 747    | 390 | 1137  | 260 | 208 | 81     |
| RL8-160 | 807    | 390 | 1197  | 260 | 208 | 84     |
| RL8-180 | 867    | 390 | 1257  | 260 | 208 | 93     |
| RL8-200 | 927    | 390 | 1317  | 260 | 208 | 94     |

## 性能表

| 型号      | 配用电机<br>(kW) | Q<br>(m <sup>3</sup> /h) | 5   | 6    | 7    | 8   | 9   | 10  | 11  | 12  |
|---------|--------------|--------------------------|-----|------|------|-----|-----|-----|-----|-----|
| RL8-20  | 0.75         | H<br>(m)                 | 20  | 19.5 | 19   | 18  | 17  | 16  | 14  | 13  |
| RL8-30  | 1.1          |                          | 30  | 29.5 | 28.5 | 27  | 25  | 24  | 21  | 19  |
| RL8-40  | 1.5          |                          | 41  | 39.5 | 38   | 36  | 34  | 32  | 28  | 26  |
| RL8-50  | 2.2          |                          | 52  | 50   | 48   | 45  | 42  | 40  | 36  | 32  |
| RL8-60  | 2.2          |                          | 62  | 60   | 57   | 54  | 51  | 48  | 43  | 39  |
| RL8-80  | 3.0          |                          | 83  | 80   | 77   | 73  | 69  | 65  | 58  | 52  |
| RL8-100 | 4.0          |                          | 104 | 100  | 97   | 92  | 87  | 81  | 73  | 65  |
| RL8-120 | 4.0          |                          | 124 | 120  | 116  | 111 | 104 | 92  | 87  | 78  |
| RL8-140 | 5.5          |                          | 145 | 141  | 136  | 130 | 122 | 113 | 102 | 92  |
| RL8-160 | 5.5          |                          | 166 | 161  | 156  | 148 | 139 | 130 | 118 | 106 |
| RL8-180 | 7.5          |                          | 187 | 182  | 175  | 167 | 157 | 146 | 134 | 120 |
| RL8-200 | 7.5          |                          | 208 | 202  | 195  | 186 | 175 | 163 | 150 | 135 |

单相电机、隔爆电机外形尺寸有所变动，详情请咨询本公司。

## 性能曲线

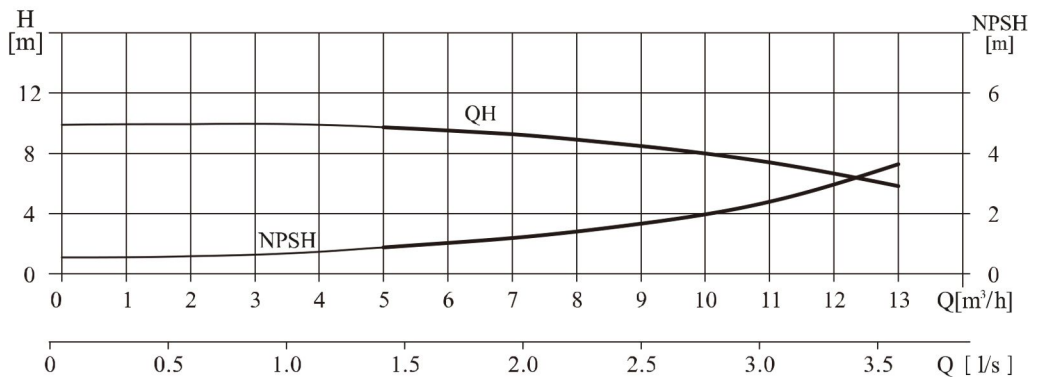
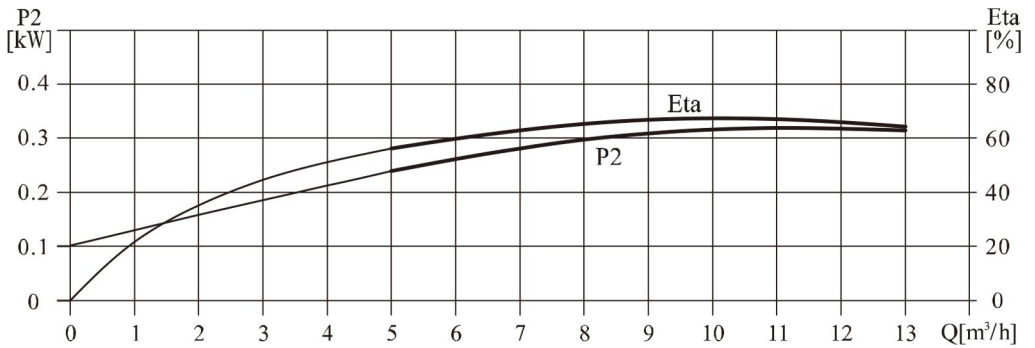
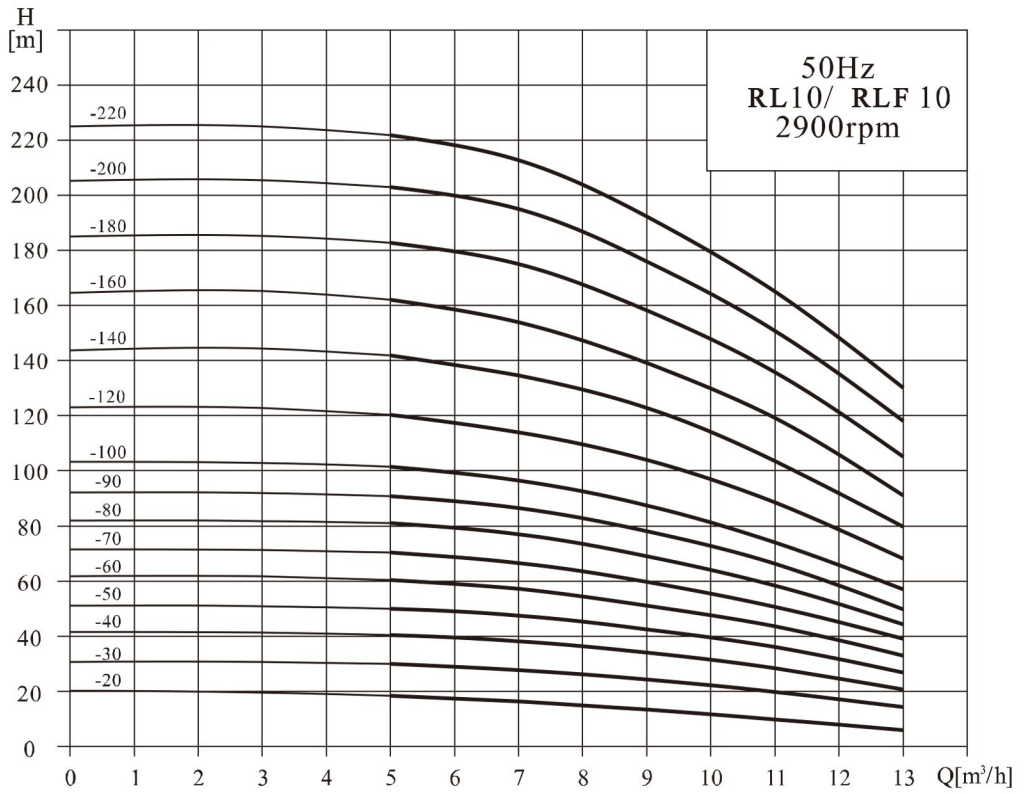



## 安装图

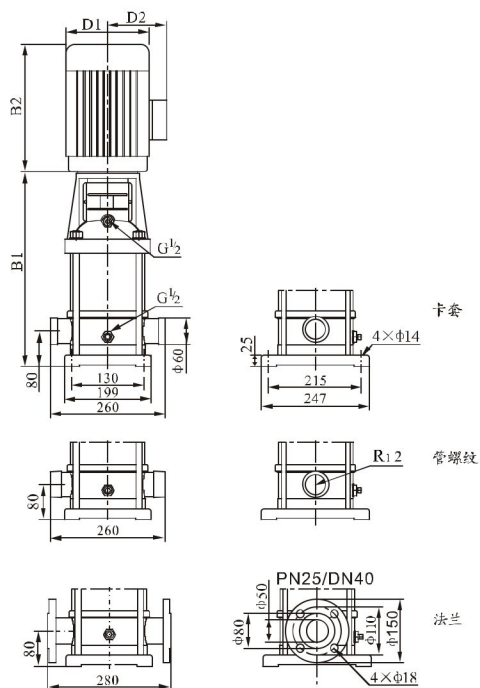

## 尺寸和重量

| 型号       | 尺寸(mm) |     |       |     |     | 重量(kg) |
|----------|--------|-----|-------|-----|-----|--------|
|          | B1     | B2  | B1+B2 | D1  | D2  |        |
| RL10-20  | 347    | 245 | 592   | 170 | 142 | 32     |
| RL10-30  | 377    | 245 | 722   | 170 | 142 | 34     |
| RL10-40  | 417    | 290 | 707   | 190 | 155 | 40     |
| RL10-50  | 447    | 290 | 737   | 190 | 155 | 44     |
| RL10-60  | 477    | 290 | 767   | 190 | 155 | 45     |
| RL10-70  | 517    | 345 | 862   | 197 | 165 | 52     |
| RL10-80  | 547    | 345 | 892   | 197 | 165 | 53     |
| RL10-90  | 577    | 345 | 922   | 197 | 165 | 54     |
| RL10-100 | 607    | 355 | 962   | 230 | 185 | 64     |
| RL10-120 | 667    | 355 | 1022  | 230 | 185 | 66     |
| RL10-140 | 747    | 390 | 1137  | 260 | 210 | 81     |
| RL10-160 | 807    | 390 | 1197  | 260 | 210 | 82     |
| RL10-180 | 867    | 390 | 1257  | 260 | 210 | 93     |
| RL10-200 | 927    | 390 | 1317  | 260 | 210 | 94     |
| RL10-220 | 987    | 390 | 1377  | 260 | 210 | 95     |

## 性能表

| 型号       | 配用电机 (kW) | Q (m <sup>3</sup> /h) | 5     | 6    | 7     | 8     | 9    | 10   | 11    | 12   | 13   |
|----------|-----------|-----------------------|-------|------|-------|-------|------|------|-------|------|------|
| RL10-20  | 0.75      | H (m)                 | 18.5  | 17   | 16    | 14    | 13   | 12   | 10    | 8.5  | 7    |
| RL10-30  | 1.1       |                       | 30    | 28.5 | 27.5  | 25.5  | 24.5 | 22   | 20    | 18   | 14.5 |
| RL10-40  | 1.5       |                       | 40.5  | 39.5 | 38.5  | 36.5  | 34   | 31.5 | 28.5  | 25.5 | 21   |
| RL10-50  | 2.2       |                       | 50    | 49   | 47.5  | 45.5  | 42.5 | 39.5 | 36    | 32   | 27   |
| RL10-60  | 2.2       |                       | 60    | 59   | 57    | 55    | 51   | 47.5 | 43.5  | 39   | 33.5 |
| RL10-70  | 3.0       |                       | 70.5  | 69   | 66.5  | 64    | 59.5 | 55.5 | 50.5  | 45.5 | 39   |
| RL10-80  | 3.0       |                       | 81    | 79   | 77    | 74.5  | 69   | 64   | 58.5  | 53   | 44.5 |
| RL10-90  | 3.0       |                       | 91    | 89   | 86.5  | 82.5  | 78   | 72   | 66.5  | 59.5 | 50   |
| RL10-100 | 4.0       |                       | 101.5 | 99   | 96.5  | 92.5  | 87.5 | 81.5 | 74    | 67   | 57   |
| RL10-120 | 4.0       |                       | 120.5 | 119  | 114   | 110   | 104  | 97   | 88.5  | 80   | 68   |
| RL10-140 | 5.5       |                       | 142   | 139  | 134.5 | 131   | 123  | 114  | 103.5 | 93.5 | 80   |
| RL10-160 | 5.5       |                       | 162   | 159  | 154   | 148.5 | 139  | 130  | 119   | 107  | 91   |
| RL10-180 | 7.5       |                       | 183   | 180  | 175   | 167   | 158  | 148  | 136   | 121  | 105  |
| RL10-200 | 7.5       |                       | 203   | 200  | 195   | 186   | 176  | 165  | 151   | 134  | 118  |
| RL10-220 | 7.5       |                       | 222   | 219  | 213   | 203   | 192  | 179  | 165   | 149  | 130  |

单相电机、隔爆电机外形尺寸有所变动，详情请咨询本公司。

## 性能曲线

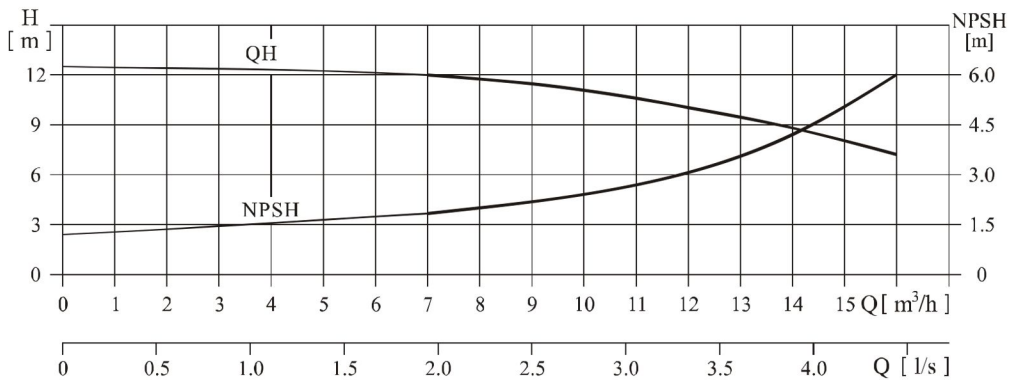
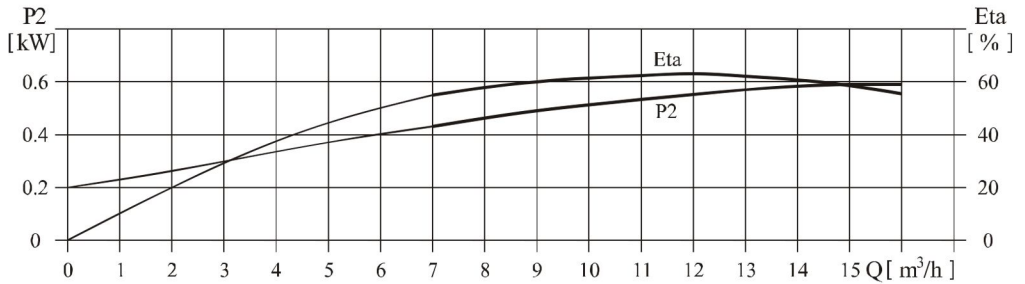
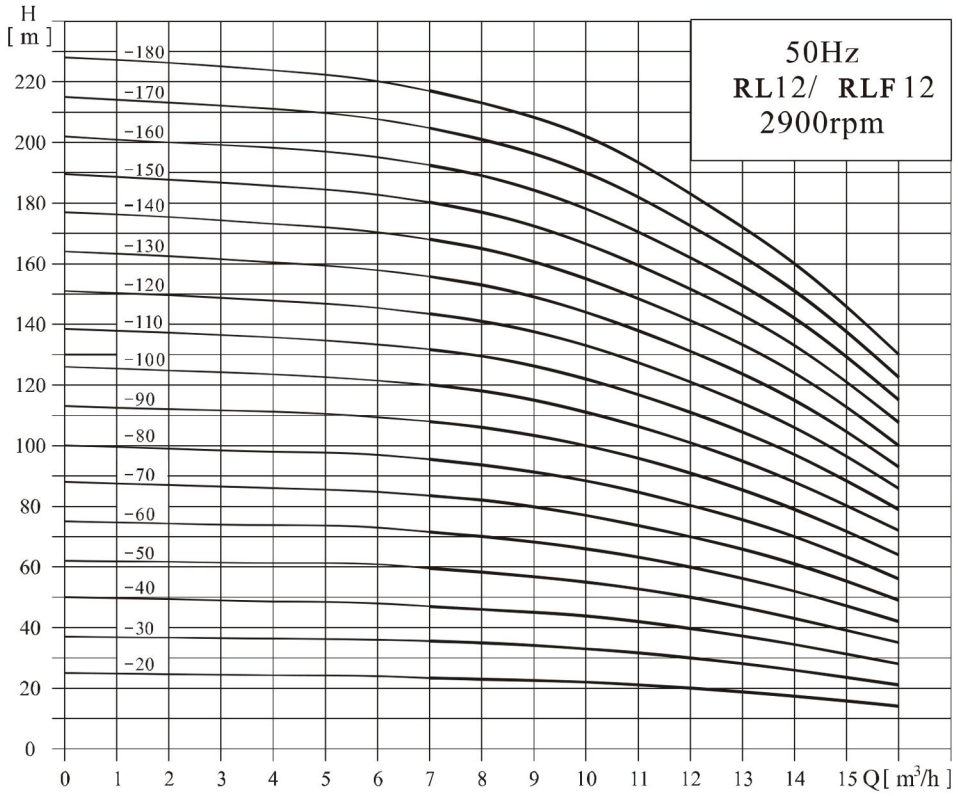

## 安装图

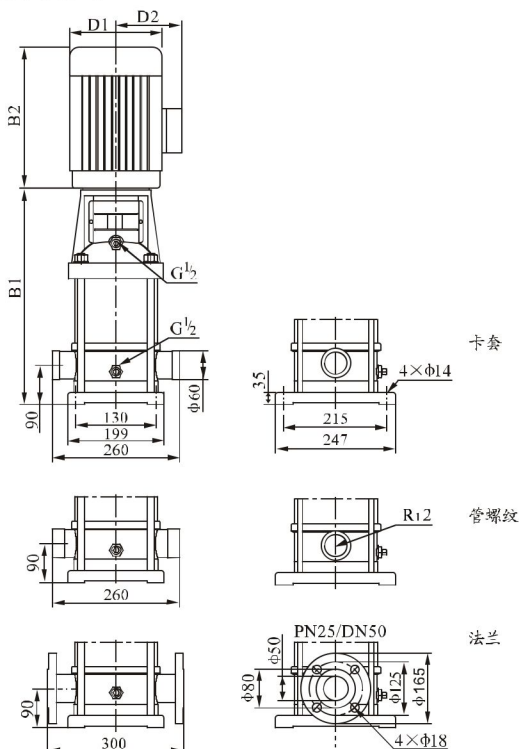

## 尺寸和重量

| 型号       | 尺寸(mm) |     |       |     |     | 重量(kg) |
|----------|--------|-----|-------|-----|-----|--------|
|          | B1     | B2  | B1+B2 | D1  | D2  |        |
| RL12-20  | 367    | 290 | 657   | 190 | 155 | 39     |
| RL12-30  | 397    | 290 | 687   | 190 | 155 | 43     |
| RL12-40  | 437    | 345 | 782   | 197 | 165 | 51     |
| RL12-50  | 467    | 345 | 812   | 197 | 165 | 53     |
| RL12-60  | 497    | 355 | 852   | 230 | 188 | 61     |
| RL12-70  | 547    | 390 | 937   | 260 | 208 | 73     |
| RL12-80  | 577    | 390 | 967   | 260 | 208 | 74     |
| RL12-90  | 607    | 390 | 997   | 260 | 208 | 76     |
| RL12-100 | 637    | 390 | 1027  | 260 | 208 | 83     |
| RL12-120 | 697    | 390 | 1087  | 260 | 208 | 87     |
| RL12-140 | 845    | 500 | 1345  | 330 | 255 | 158    |
| RL12-160 | 905    | 500 | 1405  | 330 | 255 | 161    |
| RL12-180 | 965    | 500 | 1465  | 330 | 255 | 164    |

## 性能表

| 型号       | 配用电机<br>(kW) | Q<br>(m <sup>3</sup> /h) | 7     | 8     | 9     | 10    | 11   | 12    | 13    | 14  | 15    | 16  |
|----------|--------------|--------------------------|-------|-------|-------|-------|------|-------|-------|-----|-------|-----|
| RL12-20  | 1.5          | H<br>(m)                 | 23.5  | 23    | 22.5  | 22    | 21   | 20    | 18.5  | 17  | 15.5  | 14  |
| RL12-30  | 2.2          |                          | 35.5  | 35    | 34    | 33    | 31.5 | 30    | 28    | 26  | 23.5  | 21  |
| RL12-40  | 3            |                          | 47    | 46    | 45    | 44    | 42   | 40    | 37    | 34  | 31    | 28  |
| RL12-50  | 3            |                          | 59.5  | 58    | 56.5  | 55    | 52.5 | 50    | 46.5  | 43  | 39    | 35  |
| RL12-60  | 4            |                          | 71.5  | 70    | 68    | 66    | 63   | 60    | 56    | 52  | 47    | 42  |
| RL12-70  | 5.5          |                          | 83.5  | 82    | 79.5  | 77    | 73.5 | 70    | 65.5  | 61  | 55    | 49  |
| RL12-80  | 5.5          |                          | 95.5  | 94    | 91    | 88    | 84   | 80    | 75    | 70  | 63    | 56  |
| RL12-90  | 5.5          |                          | 108   | 106   | 103   | 100   | 95.5 | 91    | 85    | 79  | 71.5  | 64  |
| RL12-100 | 7.5          |                          | 120   | 118   | 114.5 | 111   | 106  | 101   | 94.5  | 88  | 80    | 72  |
| RL12-120 | 7.5          |                          | 143.5 | 141   | 137   | 133   | 127  | 121   | 113.5 | 106 | 96    | 86  |
| RL12-140 | 11           |                          | 168   | 165   | 160   | 155   | 148  | 141   | 132.5 | 124 | 112   | 100 |
| RL12-160 | 11           |                          | 192.5 | 189   | 183.5 | 178   | 170  | 162   | 152   | 142 | 128.5 | 115 |
| RL12-180 | 11           | 217                      | 213   | 207.5 | 202   | 192.5 | 183  | 171.5 | 160   | 145 | 130   |     |

单相电机、隔爆电机外形尺寸有所变动，详情请咨询本公司。

## 性能曲线

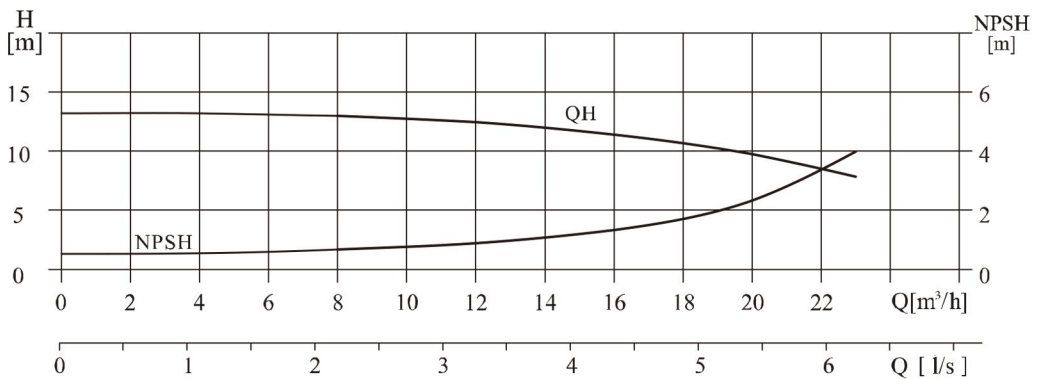
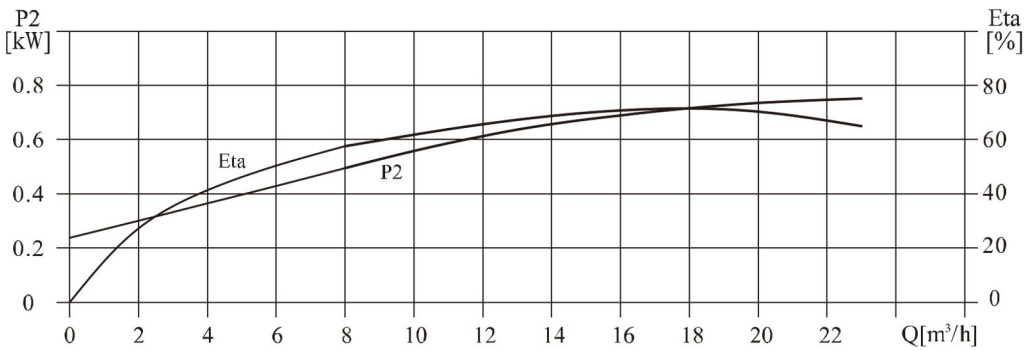
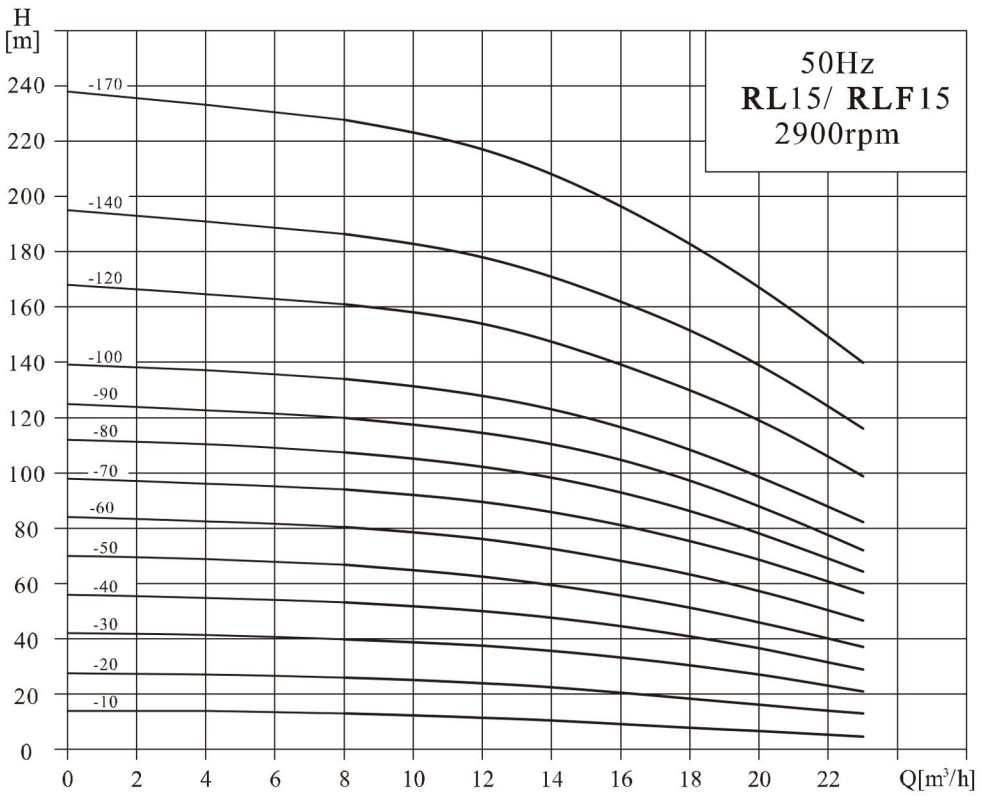

## 安装图

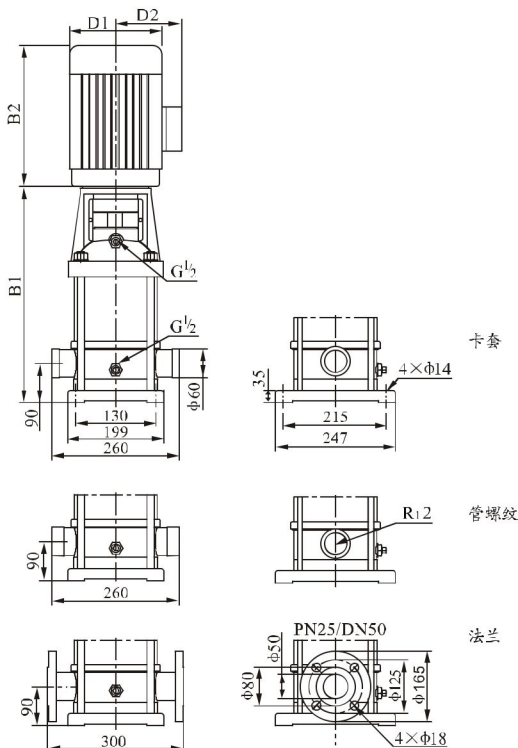

## 尺寸和重量

| 型号       | 尺寸(mm) |     |       |     |     | 重量(kg) |
|----------|--------|-----|-------|-----|-----|--------|
|          | B1     | B2  | B1+B2 | D1  | D2  |        |
| RL15-10  | 352    | 245 | 597   | 170 | 142 | 33     |
| RL15-20  | 397    | 290 | 687   | 190 | 155 | 42     |
| RL15-30  | 452    | 345 | 797   | 197 | 165 | 50     |
| RL15-40  | 497    | 355 | 852   | 230 | 185 | 59     |
| RL15-50  | 542    | 355 | 897   | 230 | 185 | 60     |
| RL15-60  | 607    | 390 | 997   | 260 | 210 | 77     |
| RL15-70  | 652    | 390 | 1042  | 260 | 210 | 78     |
| RL15-80  | 697    | 390 | 1087  | 260 | 210 | 86     |
| RL15-90  | 742    | 390 | 1132  | 260 | 210 | 87     |
| RL15-100 | 875    | 500 | 1375  | 330 | 255 | 160    |
| RL15-120 | 965    | 500 | 1465  | 330 | 255 | 161    |
| RL15-140 | 1055   | 500 | 1555  | 330 | 255 | 162    |
| RL15-170 | 1190   | 500 | 1690  | 330 | 255 | 179    |

## 性能表

| 型号       | 配用电机<br>(kW) | Q<br>(m <sup>3</sup> /h) | 8     | 10   | 12    | 14   | 15   | 16    | 18    | 20   | 23   |
|----------|--------------|--------------------------|-------|------|-------|------|------|-------|-------|------|------|
| RL15-10  | 1.1          | H<br>(m)                 | 13    | 12   | 11.5  | 10.5 | 10   | 9     | 7.5   | 6    | 4.5  |
| RL15-20  | 2.2          |                          | 26    | 25   | 24    | 23   | 22   | 20.5  | 18    | 16   | 13   |
| RL15-30  | 3.0          |                          | 39.5  | 38.5 | 37.5  | 35.5 | 34.5 | 33.5  | 30.5  | 27   | 21   |
| RL15-40  | 4.0          |                          | 53    | 51.5 | 50    | 47.5 | 46   | 44.5  | 41    | 36.5 | 29   |
| RL15-50  | 4.0          |                          | 67    | 64.5 | 62.5  | 60   | 58   | 55.5  | 52    | 46   | 37   |
| RL15-60  | 5.5          |                          | 80.5  | 78   | 76    | 73   | 70.5 | 68    | 63.5  | 57   | 46.5 |
| RL15-70  | 5.5          |                          | 94    | 92   | 89.5  | 86   | 83.5 | 81    | 75.5  | 68.5 | 56.5 |
| RL15-80  | 7.5          |                          | 107.5 | 106  | 102.5 | 98.5 | 96   | 93    | 86.5  | 78   | 64.5 |
| RL15-90  | 7.5          |                          | 120   | 118  | 114.5 | 110  | 107  | 105   | 97    | 88   | 72   |
| RL15-100 | 11           |                          | 134   | 132  | 128   | 123  | 120  | 116.5 | 108.5 | 98.5 | 82.5 |
| RL15-120 | 11           |                          | 161   | 158  | 154   | 148  | 144  | 139   | 130   | 119  | 99   |
| RL15-140 | 11           |                          | 186   | 183  | 178   | 172  | 167  | 162   | 152   | 139  | 116  |
| RL15-170 | 15           |                          | 227   | 224  | 217   | 210  | 203  | 196   | 185   | 167  | 140  |

单相电机、隔爆电机外形尺寸有所变动，详情请咨询本公司。

## 性能曲线

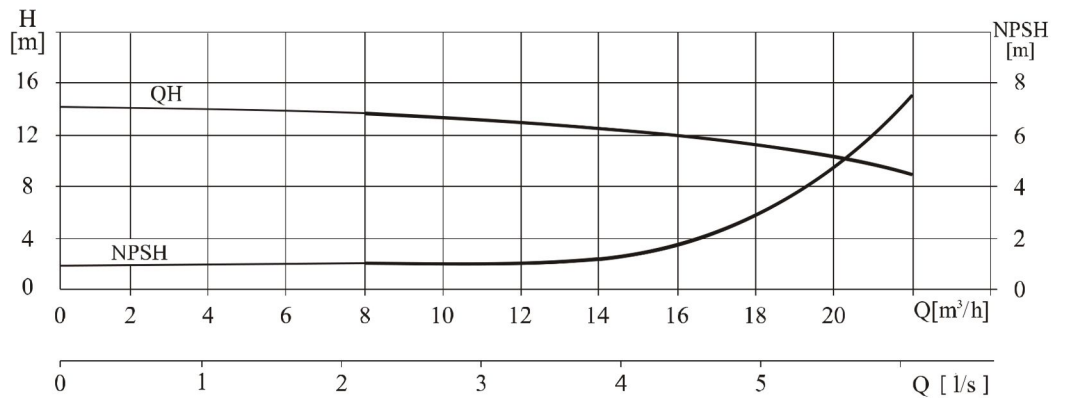
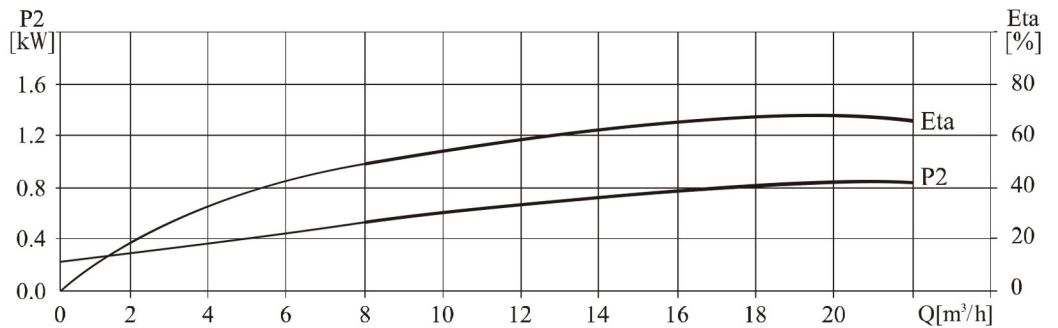
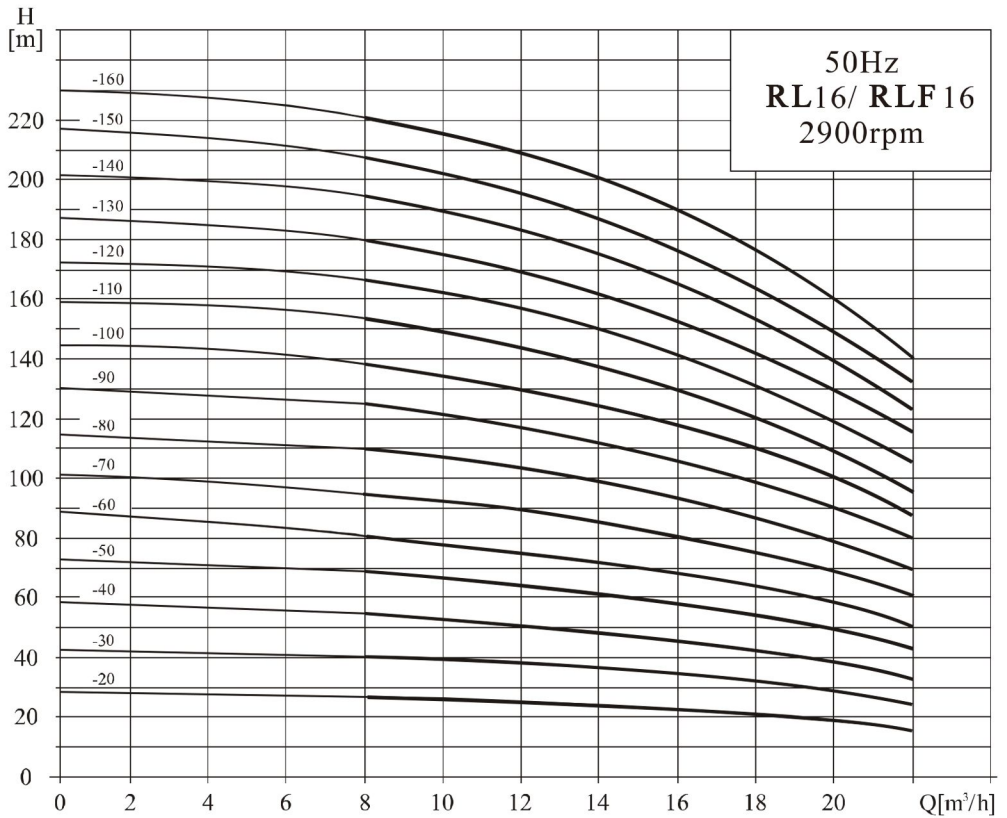

## 安装图

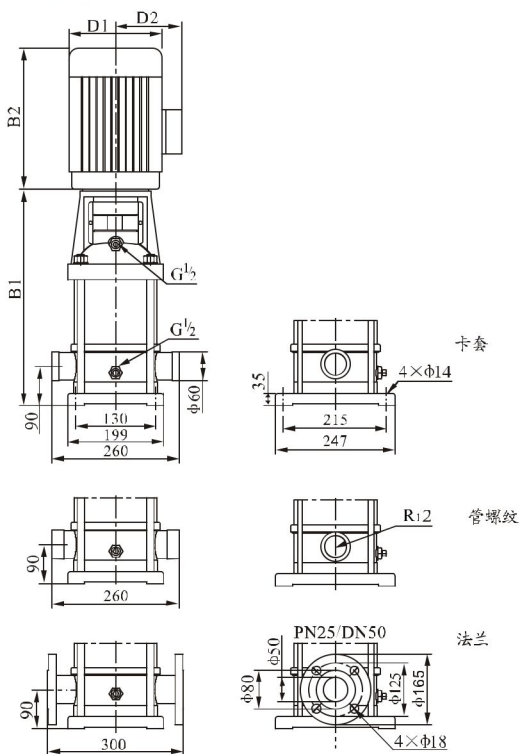

## 尺寸和重量

| 型号       | 尺寸(mm) |     |       |     |     | 重量(kg) |
|----------|--------|-----|-------|-----|-----|--------|
|          | B1     | B2  | B1+B2 | D1  | D2  |        |
| RL16-20  | 397    | 290 | 687   | 190 | 155 | 42     |
| RL16-30  | 452    | 345 | 797   | 197 | 165 | 50     |
| RL16-40  | 497    | 355 | 852   | 230 | 188 | 59     |
| RL16-50  | 562    | 390 | 952   | 260 | 208 | 76     |
| RL16-60  | 607    | 390 | 997   | 260 | 208 | 77     |
| RL16-70  | 652    | 390 | 1042  | 260 | 208 | 84     |
| RL16-80  | 697    | 390 | 1087  | 260 | 208 | 86     |
| RL16-100 | 875    | 500 | 1375  | 330 | 255 | 158    |
| RL16-120 | 965    | 500 | 1465  | 330 | 255 | 161    |
| RL16-140 | 1055   | 500 | 1555  | 330 | 255 | 174    |
| RL16-160 | 1145   | 500 | 1645  | 330 | 255 | 178    |

## 性能表

| 型号       | 配用电机<br>(kW) | Q<br>(m <sup>3</sup> /h) | H (m) |     |     |     |     |     |     |     |  |
|----------|--------------|--------------------------|-------|-----|-----|-----|-----|-----|-----|-----|--|
|          |              |                          | 8     | 10  | 12  | 14  | 16  | 18  | 20  | 22  |  |
| RL16-20  | 2.2          | H (m)                    | 27    | 26  | 25  | 24  | 22  | 21  | 19  | 16  |  |
| RL16-30  | 3.0          |                          | 41    | 40  | 38  | 37  | 34  | 32  | 29  | 25  |  |
| RL16-40  | 4.0          |                          | 54    | 53  | 52  | 49  | 46  | 43  | 38  | 34  |  |
| RL16-50  | 5.5          |                          | 68    | 67  | 65  | 62  | 58  | 54  | 48  | 43  |  |
| RL16-60  | 5.5          |                          | 82    | 80  | 78  | 74  | 70  | 64  | 58  | 52  |  |
| RL16-70  | 7.5          |                          | 96    | 95  | 91  | 87  | 82  | 76  | 68  | 61  |  |
| RL16-80  | 7.5          |                          | 110   | 108 | 104 | 99  | 94  | 86  | 77  | 70  |  |
| RL16-100 | 11           |                          | 138   | 136 | 131 | 125 | 118 | 109 | 97  | 87  |  |
| RL16-120 | 11           |                          | 166   | 162 | 157 | 150 | 141 | 130 | 116 | 105 |  |
| RL16-140 | 15           |                          | 194   | 190 | 184 | 175 | 166 | 152 | 136 | 122 |  |
| RL16-160 | 15           |                          | 222   | 217 | 210 | 200 | 189 | 174 | 156 | 140 |  |

单相电机、隔爆电机外形尺寸有所变动，详情请咨询本公司。

## 性能曲线

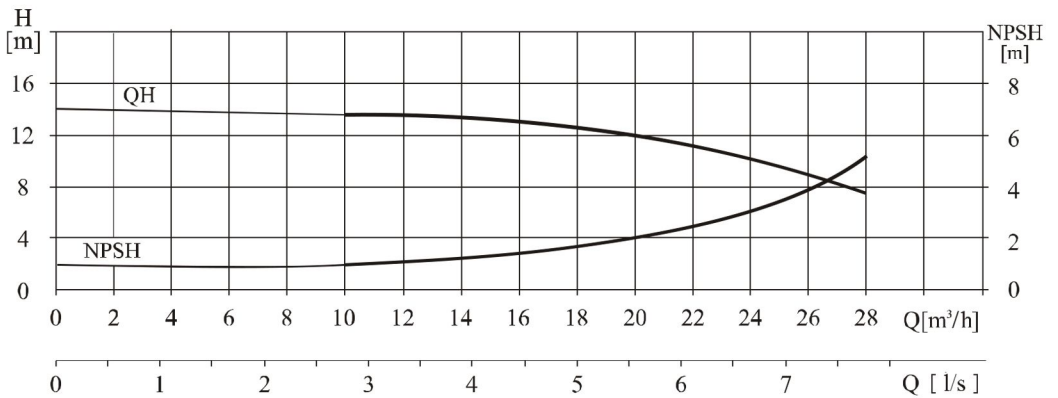
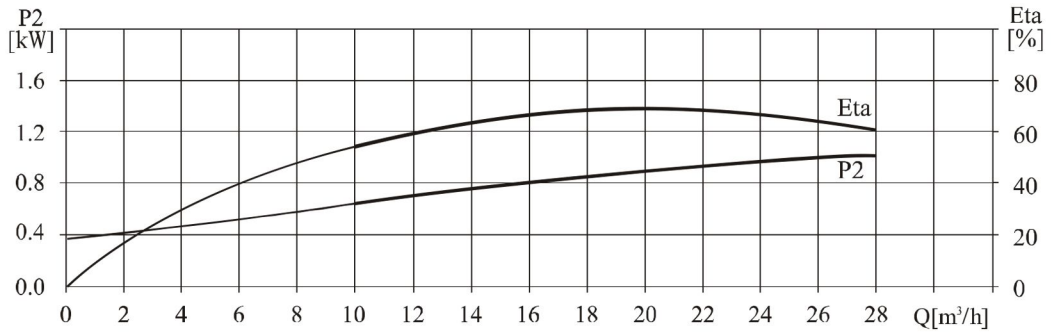
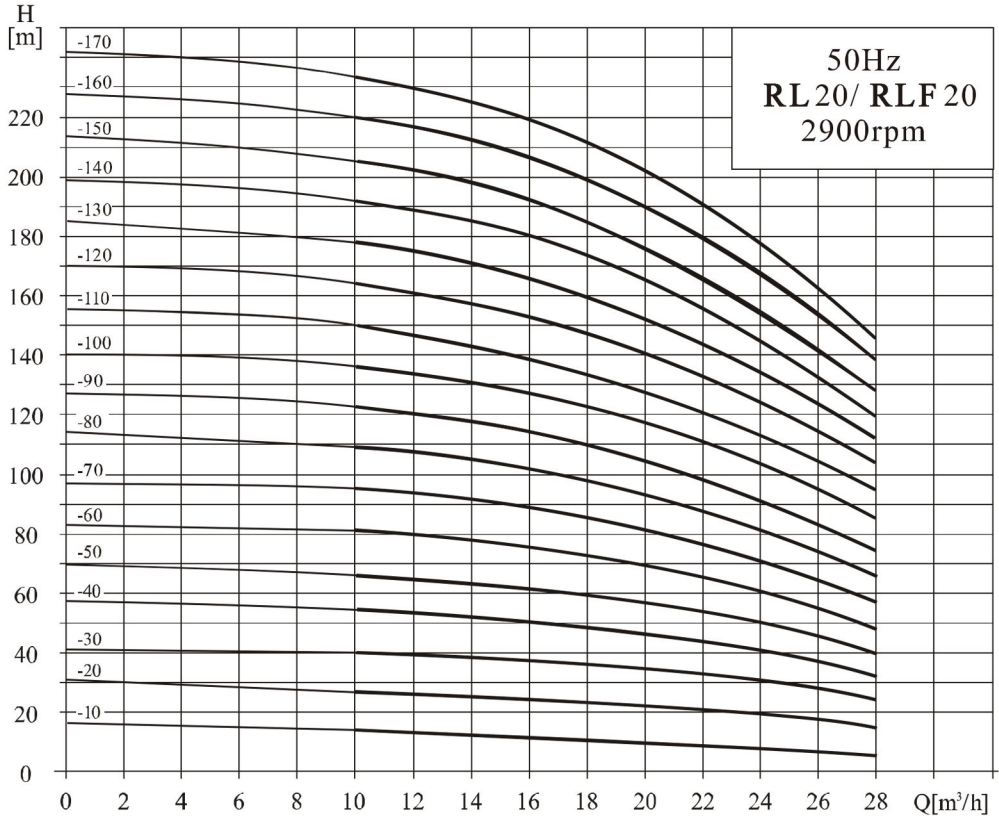



## 安装图

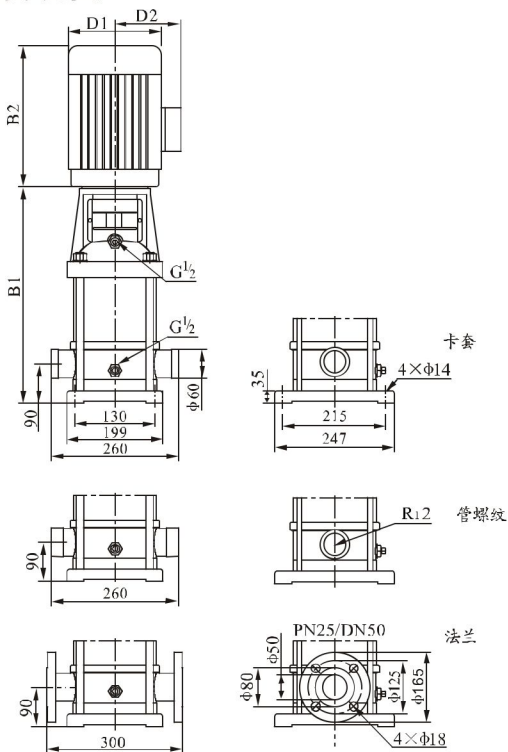

## 尺寸和重量

| 型号        | 尺寸(mm) |     |       |     |     | 重量(kg) |
|-----------|--------|-----|-------|-----|-----|--------|
|           | B1     | B2  | B1+B2 | D1  | D2  |        |
| RL 20-10  | 387    | 245 | 632   | 170 | 142 | 33     |
| RL 20-20  | 397    | 290 | 687   | 190 | 155 | 42     |
| RL 20-30  | 452    | 355 | 807   | 230 | 188 | 58     |
| RL 20-40  | 517    | 390 | 907   | 260 | 208 | 74     |
| RL 20-50  | 562    | 390 | 952   | 260 | 208 | 76     |
| RL 20-60  | 607    | 390 | 997   | 260 | 208 | 82     |
| RL 20-70  | 652    | 390 | 1042  | 260 | 208 | 84     |
| RL 20-80  | 785    | 500 | 1285  | 330 | 255 | 153    |
| RL 20-100 | 875    | 500 | 1375  | 330 | 255 | 157    |
| RL 20-120 | 965    | 500 | 1465  | 330 | 255 | 170    |
| RL 20-140 | 1055   | 500 | 1555  | 330 | 255 | 172    |
| RL 20-170 | 1190   | 550 | 1740  | 330 | 255 | 195    |

## 性能表

| 型号        | 配用电机<br>(kW) | Q<br>(m <sup>3</sup> /h) | H (m) |      |      |     |     |     |     |     |     |     |
|-----------|--------------|--------------------------|-------|------|------|-----|-----|-----|-----|-----|-----|-----|
|           |              |                          | 10    | 12   | 14   | 16  | 18  | 20  | 22  | 24  | 26  | 28  |
| RL 20-10  | 1.1          | H (m)                    | 13.5  | 13   | 12.5 | 12  | 11  | 10  | 9   | 8   | 7   | 6   |
| RL 20-20  | 2.2          |                          | 27    | 26.5 | 26   | 25  | 24  | 23  | 22  | 20  | 18  | 15  |
| RL 20-30  | 4.0          |                          | 40    | 39.5 | 39   | 38  | 37  | 35  | 33  | 30  | 27  | 24  |
| RL 20-40  | 5.5          |                          | 54    | 53   | 52   | 51  | 49  | 47  | 44  | 41  | 37  | 33  |
| RL 20-50  | 5.5          |                          | 67    | 66   | 64   | 62  | 60  | 58  | 55  | 50  | 45  | 40  |
| RL 20-60  | 7.5          |                          | 81    | 79   | 77   | 75  | 73  | 70  | 66  | 61  | 55  | 49  |
| RL 20-70  | 7.5          |                          | 95    | 93   | 91   | 89  | 86  | 82  | 77  | 71  | 65  | 58  |
| RL 20-80  | 11           |                          | 109   | 107  | 105  | 102 | 99  | 94  | 89  | 82  | 75  | 67  |
| RL 20-100 | 11           |                          | 136   | 134  | 131  | 128 | 124 | 118 | 111 | 103 | 95  | 85  |
| RL 20-120 | 15           |                          | 164   | 162  | 158  | 154 | 149 | 142 | 133 | 124 | 114 | 102 |
| RL 20-140 | 15           |                          | 192   | 189  | 185  | 180 | 174 | 166 | 156 | 145 | 133 | 119 |
| RL 20-170 | 18.5         |                          | 234   | 230  | 225  | 219 | 212 | 202 | 190 | 177 | 162 | 145 |

单相电机、隔爆电机外形尺寸有所变动，详情请咨询本公司。

## 性能曲线

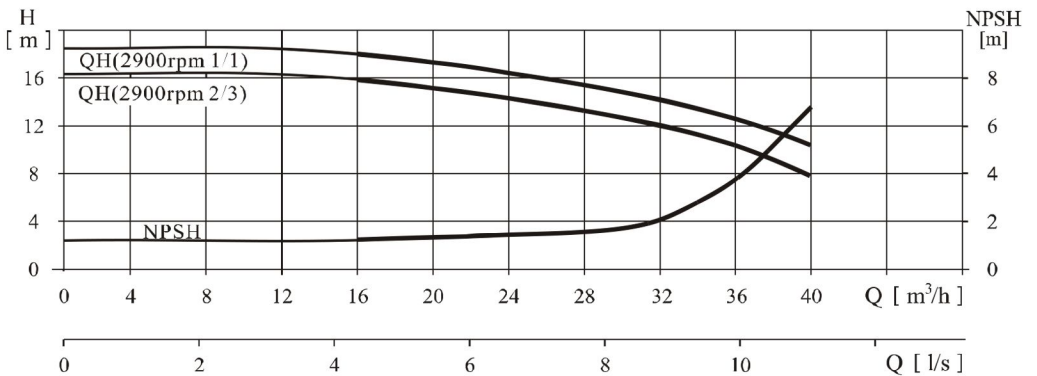
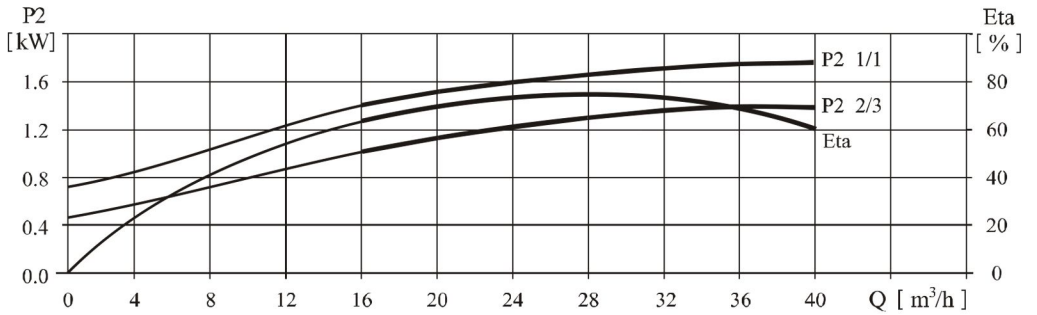
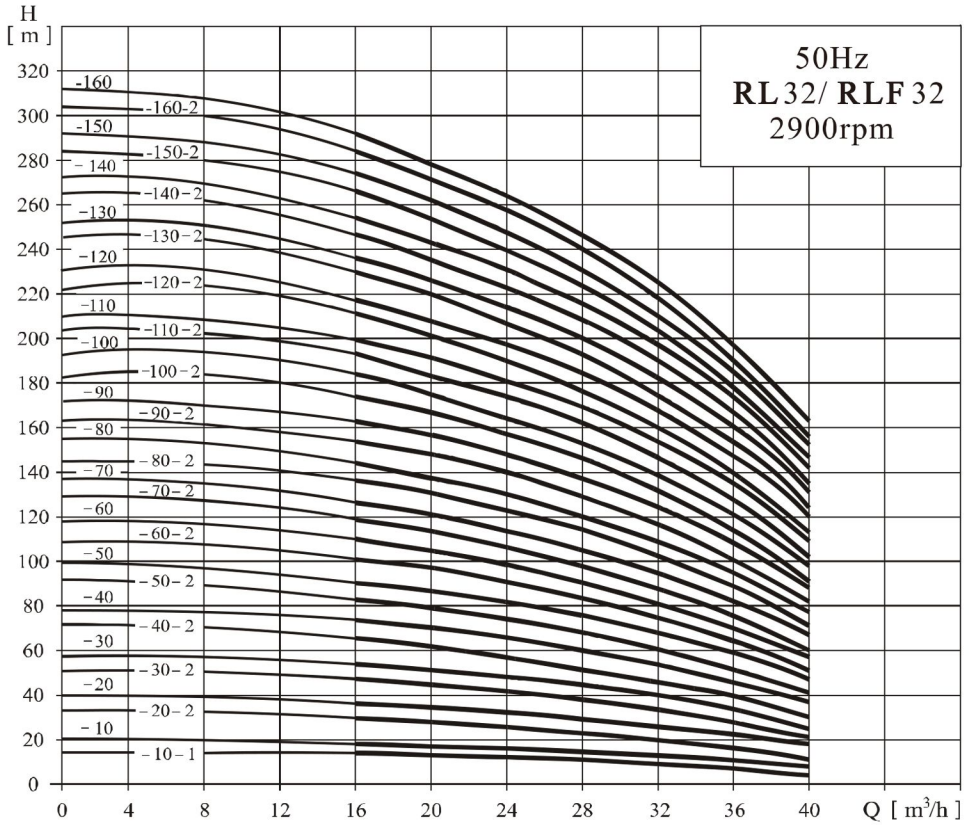

## 安装图

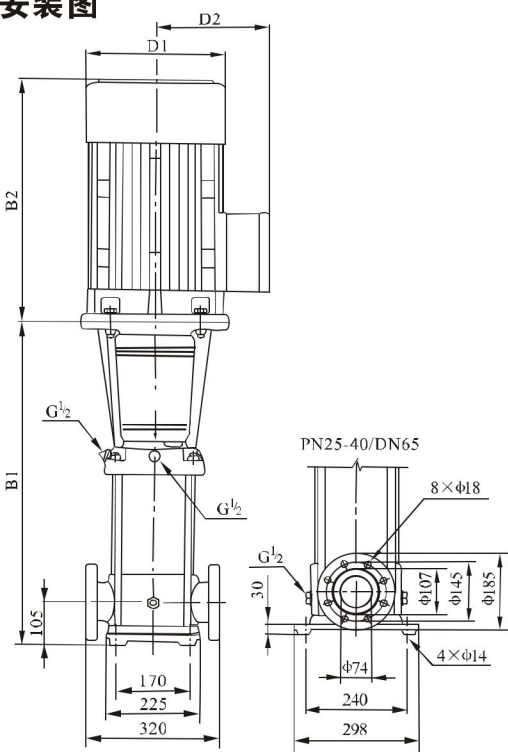

## 尺寸和重量

| 型号                     | 尺寸(mm) |         |         |         |         | 重量(kg) |
|------------------------|--------|---------|---------|---------|---------|--------|
|                        | B1     | B2      | B1+B2   | D1      | D2      |        |
| RL 32-10-1/ RL 32-10   | 505    | 290     | 795     | 190     | 155     | 64/68  |
| RL 32-20-2/ RL 32-20   | 575    | 345/355 | 920/930 | 197/230 | 165/180 | 77/85  |
| RL 32-30-2/ RL 32-30   | 645    | 390     | 1035    | 260     | 208     | 100    |
| RL 32-40-2/ RL 32-40   | 715    | 390     | 1105    | 260     | 208     | 109    |
| RL 32-50-2/ RL 32-50   | 890    | 500     | 1390    | 330     | 255     | 181    |
| RL 32-60-2/ RL 32-60   | 960    | 500     | 1460    | 330     | 255     | 185    |
| RL 32-70-2/ RL 32-70   | 1030   | 500     | 1530    | 330     | 255     | 199    |
| RL 32-80-2/ RL 32-80   | 1100   | 500     | 1600    | 330     | 255     | 203    |
| RL 32-90-2/ RL 32-90   | 1170   | 550     | 1720    | 330     | 255     | 222    |
| RL 32-100-2/ RL 32-100 | 1240   | 550     | 1790    | 330     | 255     | 227    |
| RL 32-110-2/ RL 32-110 | 1310   | 575     | 1885    | 360     | 285     | 272    |
| RL 32-120-2/ RL 32-120 | 1380   | 575     | 1955    | 360     | 285     | 276    |
| RL 32-130-2/ RL 32-130 | 1450   | 650     | 2100    | 400     | 310     | 337    |
| RL 32-140-2/ RL 32-140 | 1520   | 650     | 2170    | 400     | 310     | 341    |
| RL 32-150-2/ RL 32-150 | 1590   | 650     | 2240    | 400     | 310     | 345    |
| RL 32-160-2/ RL 32-160 | 1660   | 650     | 2310    | 400     | 310     | 350    |

## 性能表

| 型号         | 配用电机<br>(kW) | Q<br>(m <sup>3</sup> /h) | H (m) |     |     |     |     |    |    |
|------------|--------------|--------------------------|-------|-----|-----|-----|-----|----|----|
|            |              |                          | 16    | 20  | 24  | 28  | 32  | 36 | 40 |
| RL 32-10-1 | 1.5          | H<br>(m)                 | 14    | 13  | 12  | 11  | 9   | 7  | 4  |
| RL 32-10   | 2.2          |                          | 18    | 17  | 15  | 14  | 13  | 11 | 8  |
| RL 32-20-2 | 3.0          |                          | 29    | 28  | 26  | 23  | 20  | 16 | 11 |
| RL 32-20   | 4.0          |                          | 36    | 34  | 32  | 29  | 27  | 23 | 18 |
| RL 32-30-2 | 5.5          |                          | 47    | 44  | 41  | 38  | 33  | 28 | 21 |
| RL 32-30   | 5.5          |                          | 54    | 51  | 48  | 44  | 40  | 35 | 27 |
| RL 32-40-2 | 7.5          |                          | 65    | 62  | 58  | 53  | 46  | 40 | 30 |
| RL 32-40   | 7.5          |                          | 72    | 69  | 65  | 59  | 53  | 47 | 37 |
| RL 32-50-2 | 11           |                          | 83    | 79  | 74  | 68  | 60  | 52 | 41 |
| RL 32-50   | 11           |                          | 90    | 86  | 81  | 74  | 67  | 59 | 47 |
| RL 32-60-2 | 11           |                          | 101   | 97  | 90  | 83  | 74  | 65 | 51 |
| RL 32-60   | 11           |                          | 108   | 104 | 97  | 90  | 81  | 72 | 57 |
| RL 32-70-2 | 15           |                          | 119   | 114 | 107 | 98  | 88  | 78 | 60 |
| RL 32-70   | 15           |                          | 126   | 121 | 113 | 105 | 95  | 85 | 67 |
| RL 32-80-2 | 15           |                          | 136   | 131 | 123 | 114 | 102 | 90 | 71 |
| RL 32-80   | 15           |                          | 144   | 138 | 130 | 120 | 109 | 97 | 77 |

| 型号         | 配用电机<br>(kW) | Q<br>(m <sup>3</sup> /h) | H (m) |     |     |     |     |     |     |
|------------|--------------|--------------------------|-------|-----|-----|-----|-----|-----|-----|
|            |              |                          | 16    | 20  | 24  | 28  | 32  | 36  | 40  |
| RL32-90-2  | 18.5         | H<br>(m)                 | 154   | 148 | 140 | 129 | 117 | 102 | 82  |
| RL32-90    | 18.5         |                          | 162   | 156 | 147 | 136 | 124 | 109 | 88  |
| RL32-100-2 | 18.5         |                          | 175   | 166 | 157 | 146 | 131 | 115 | 91  |
| RL32-100   | 18.5         |                          | 182   | 173 | 164 | 152 | 138 | 122 | 98  |
| RL32-110-2 | 22           |                          | 193   | 184 | 173 | 164 | 146 | 128 | 102 |
| RL32-110   | 22           |                          | 200   | 191 | 180 | 168 | 153 | 135 | 109 |
| RL32-120-2 | 22           |                          | 211   | 201 | 189 | 178 | 160 | 140 | 113 |
| RL32-120   | 22           |                          | 218   | 208 | 196 | 184 | 167 | 147 | 120 |
| RL32-130-2 | 30           |                          | 230   | 218 | 206 | 193 | 174 | 153 | 124 |
| RL32-130   | 30           |                          | 237   | 225 | 213 | 200 | 181 | 160 | 131 |
| RL32-140-2 | 30           |                          | 247   | 235 | 222 | 210 | 189 | 165 | 135 |
| RL32-140   | 30           |                          | 255   | 242 | 229 | 216 | 196 | 172 | 142 |
| RL32-150-2 | 30           |                          | 266   | 253 | 239 | 224 | 203 | 178 | 145 |
| RL32-150   | 30           |                          | 274   | 260 | 246 | 231 | 210 | 185 | 152 |
| RL32-160-2 | 30           |                          | 284   | 270 | 255 | 240 | 218 | 190 | 156 |
| RL32-160   | 30           |                          | 292   | 277 | 262 | 246 | 225 | 197 | 163 |

单相电机、隔爆电机外形尺寸有所变动，详情请咨询本公司。

## 性能曲线

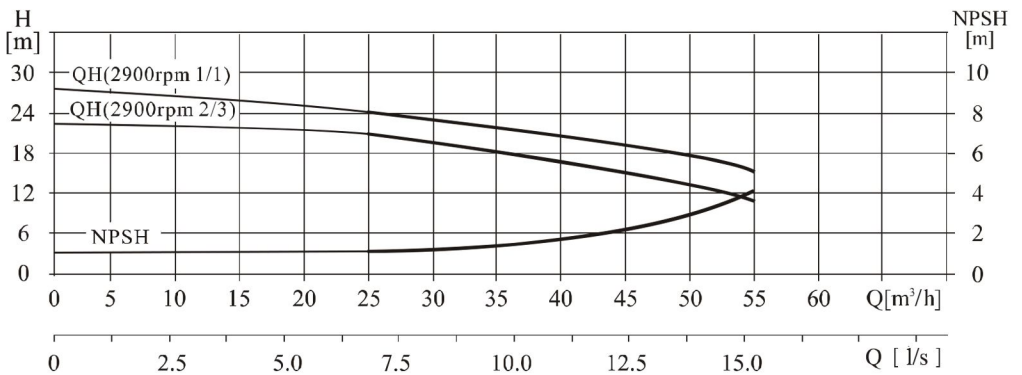
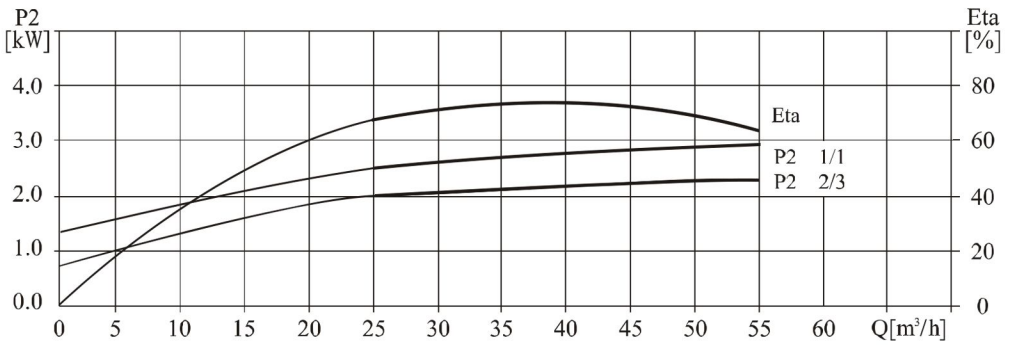
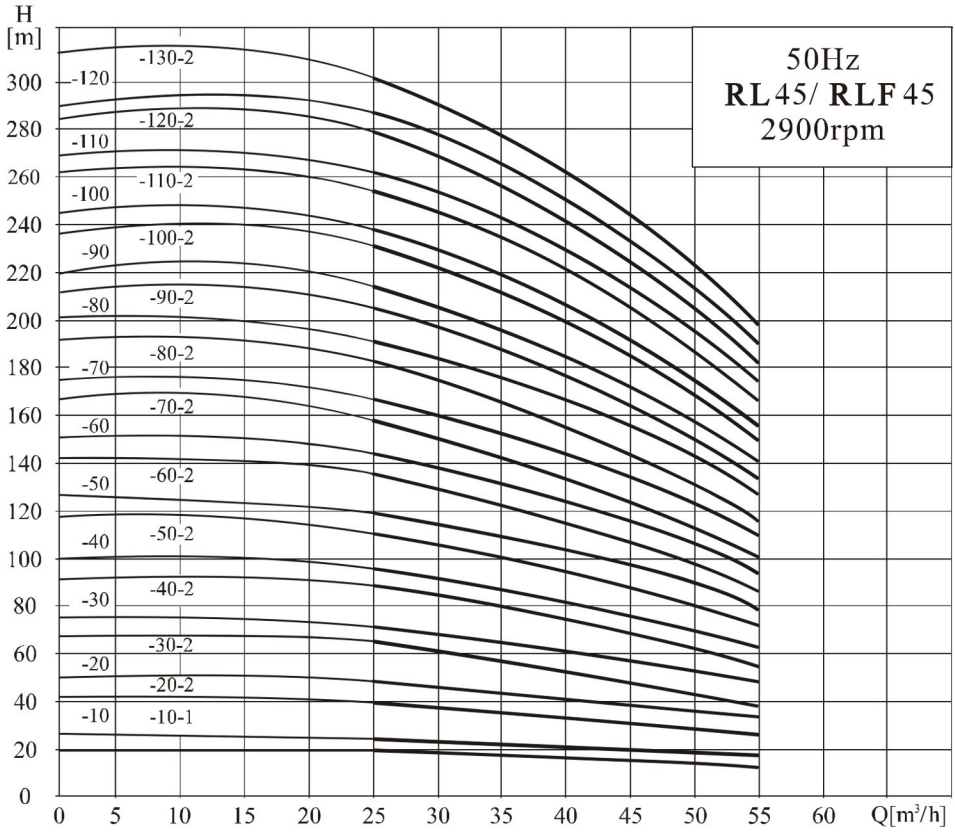

## 安装图

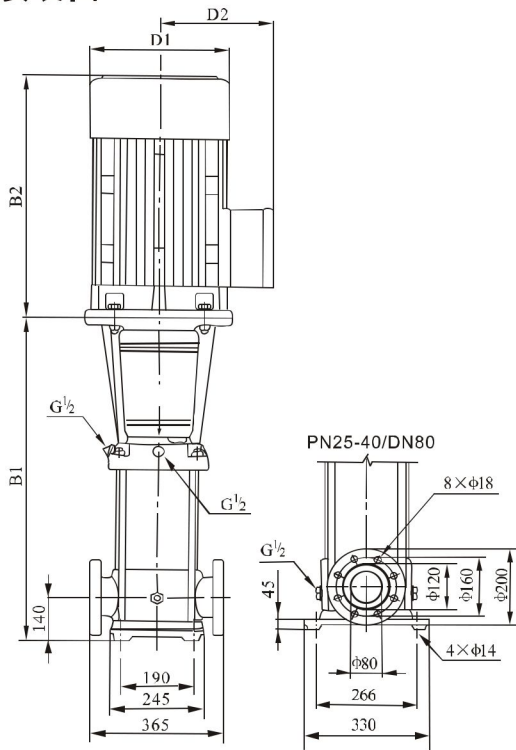

## 尺寸和重量

| 型号          | 尺寸(mm) |         |         |         |         | 重量(kg)  |
|-------------|--------|---------|---------|---------|---------|---------|
|             | B1     | B2      | B1+B2   | D1      | D2      |         |
| RL 45-10-1  | 561    | 345/355 | 906/916 | 197/230 | 165/188 | 83/90   |
| RL 45-10    |        |         |         |         |         |         |
| RL 45-20-2  | 641    | 390     | 1031    | 260     | 208     | 105/110 |
| RL 45-20    |        |         |         |         |         |         |
| RL 45-30-2  | 826    | 500     | 1326    | 330     | 255     | 183     |
| RL 45-30    |        |         |         |         |         |         |
| RL 45-40-2  | 906    | 500     | 1406    | 330     | 255     | 197     |
| RL 45-40    |        |         |         |         |         |         |
| RL 45-50-2  | 986    | 550     | 1536    | 330     | 255     | 221     |
| RL 45-50    |        |         |         |         |         |         |
| RL 45-60-2  | 1066   | 575     | 1641    | 360     | 285     | 261     |
| RL 45-60    |        |         |         |         |         |         |
| RL 45-70-2  | 1146   | 650     | 1796    | 400     | 310     | 320     |
| RL 45-70    |        |         |         |         |         |         |
| RL 45-80-2  | 1226   | 650     | 1876    | 400     | 310     | 324     |
| RL 45-80    |        |         |         |         |         |         |
| RL 45-90-2  | 1306   | 650     | 1956    | 400     | 310     | 328/352 |
| RL 45-90    |        |         |         |         |         |         |
| RL 45-100-2 | 1386   | 650     | 2036    | 400     | 310     | 355     |
| RL 45-100   |        |         |         |         |         |         |
| RL 45-110-2 | 1466   | 685     | 2151    | 450     | 345     | 426     |
| RL 45-110   |        |         |         |         |         |         |
| RL 45-120-2 | 1546   | 685     | 2231    | 450     | 345     | 432     |
| RL 45-120   |        |         |         |         |         |         |
| RL 45-130-2 | 1626   | 685     | 2311    | 450     | 345     | 438     |

## 性能表

| 型号          | 配用电机<br>(kW) | Q<br>(m <sup>3</sup> /h) | H<br>(m) |     |     |     |     |     |     |  |
|-------------|--------------|--------------------------|----------|-----|-----|-----|-----|-----|-----|--|
|             |              |                          | 25       | 30  | 35  | 40  | 45  | 50  | 55  |  |
| RL 45-10-1  | 3.0          | H<br>(m)                 | 20       | 19  | 18  | 17  | 15  | 13  | 11  |  |
| RL 45-10    | 4.0          |                          | 24       | 23  | 22  | 21  | 19  | 18  | 16  |  |
| RL 45-20-2  | 5.5          |                          | 40       | 38  | 36  | 33  | 30  | 27  | 23  |  |
| RL 45-20    | 7.5          |                          | 48       | 46  | 44  | 42  | 39  | 35  | 31  |  |
| RL 45-30-2  | 11           |                          | 63       | 61  | 58  | 54  | 50  | 44  | 38  |  |
| RL 45-30    | 11           |                          | 71       | 69  | 66  | 63  | 58  | 53  | 47  |  |
| RL 45-40-2  | 15           |                          | 87       | 84  | 80  | 75  | 69  | 62  | 54  |  |
| RL 45-40    | 15           |                          | 95       | 92  | 88  | 84  | 78  | 71  | 62  |  |
| RL 45-50-2  | 18.5         |                          | 111      | 107 | 102 | 96  | 88  | 80  | 69  |  |
| RL 45-50    | 18.5         |                          | 119      | 115 | 110 | 105 | 97  | 88  | 78  |  |
| RL 45-60-2  | 22           |                          | 135      | 130 | 124 | 117 | 108 | 97  | 85  |  |
| RL 45-60    | 22           |                          | 143      | 138 | 132 | 125 | 116 | 106 | 93  |  |
| RL 45-70-2  | 30           |                          | 158      | 152 | 146 | 138 | 127 | 115 | 100 |  |
| RL 45-70    | 30           |                          | 166      | 161 | 154 | 146 | 135 | 124 | 109 |  |
| RL 45-80-2  | 30           |                          | 182      | 175 | 168 | 159 | 146 | 133 | 116 |  |
| RL 45-80    | 30           |                          | 190      | 184 | 176 | 167 | 154 | 141 | 124 |  |
| RL 45-90-2  | 30           |                          | 205      | 198 | 190 | 180 | 166 | 150 | 132 |  |
| RL 45-90    | 37           |                          | 214      | 207 | 198 | 188 | 174 | 159 | 140 |  |
| RL 45-100-2 | 37           |                          | 230      | 221 | 212 | 200 | 185 | 168 | 147 |  |
| RL 45-100   | 37           |                          | 238      | 230 | 220 | 209 | 193 | 177 | 155 |  |
| RL 45-110-2 | 45           |                          | 255      | 246 | 236 | 223 | 206 | 188 | 165 |  |
| RL 45-110   | 45           |                          | 263      | 255 | 244 | 232 | 214 | 196 | 173 |  |
| RL 45-120-2 | 45           |                          | 280      | 270 | 259 | 245 | 226 | 206 | 181 |  |
| RL 45-120   | 45           |                          | 289      | 280 | 268 | 255 | 236 | 216 | 190 |  |
| RL 45-130-2 | 45           | 305                      | 294      | 282 | 267 | 247 | 225 | 198 |     |  |

隔爆电机外形尺寸有所变动，详情请咨询本公司。

## 性能曲线

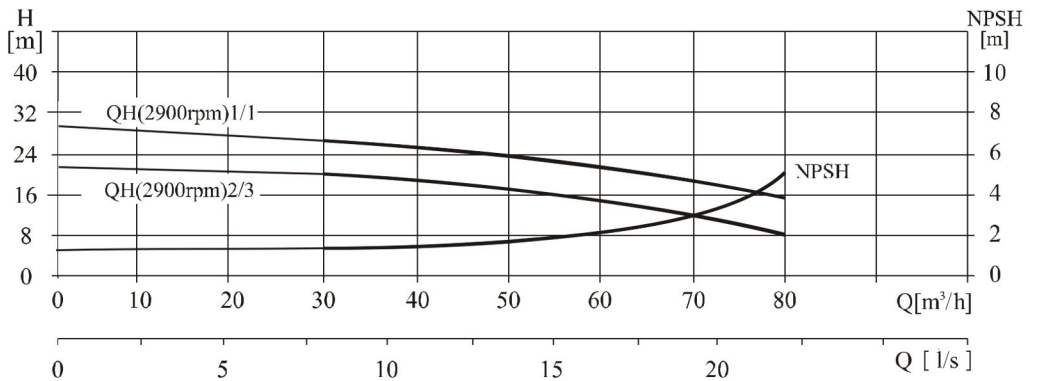
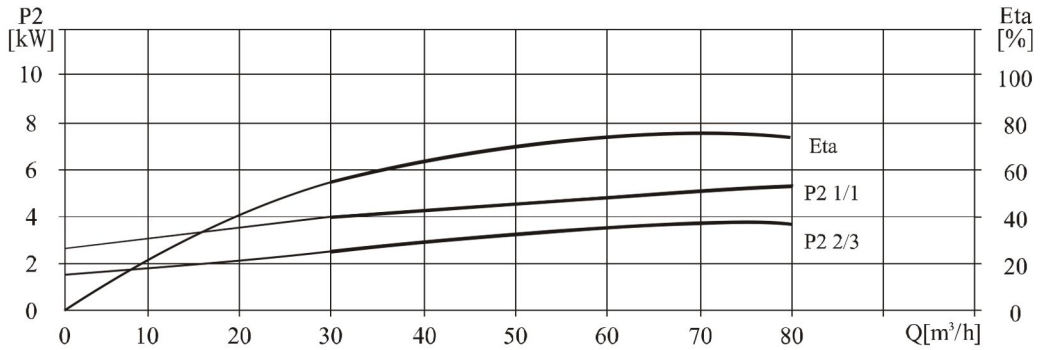
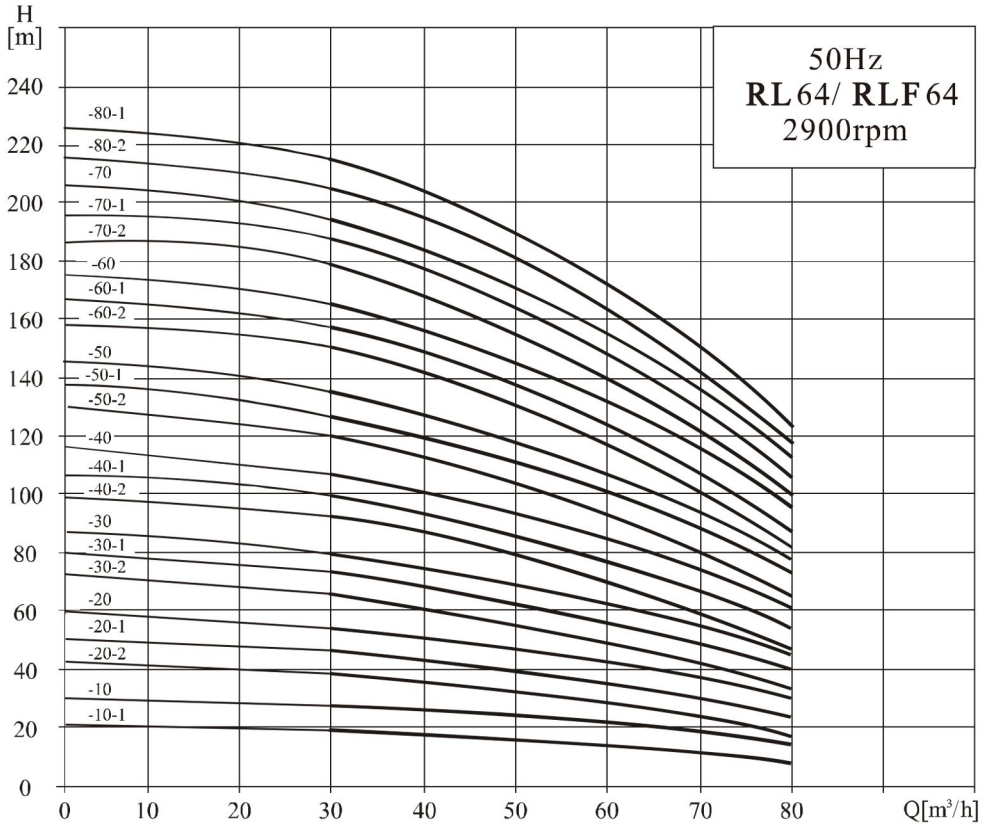

## 安装图

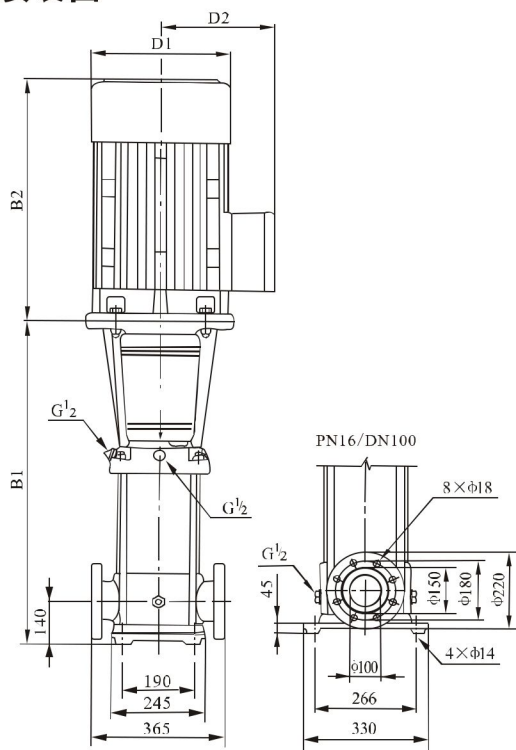

## 尺寸和重量

| 型号         | 尺寸(mm) |     |       |     |     | 重量(kg) |
|------------|--------|-----|-------|-----|-----|--------|
|            | B1     | B2  | B1+B2 | D1  | D2  |        |
| RL 64-10-1 | 561    | 355 | 916   | 230 | 188 | 93     |
| RL 64-10   | 561    | 390 | 951   | 260 | 208 | 105    |
| RL 64-20-2 | 644    | 390 | 1034  | 260 | 208 | 110    |
| RL 64-20-1 | 754    | 500 | 1254  | 330 | 255 | 182    |
| RL 64-20   | 754    | 500 | 1254  | 330 | 255 | 182    |
| RL 64-30-2 | 836    | 500 | 1336  | 330 | 255 | 196    |
| RL 64-30-1 | 836    | 500 | 1336  | 330 | 255 | 197    |
| RL 64-30   | 836    | 550 | 1386  | 330 | 255 | 221    |
| RL 64-40-2 | 919    | 550 | 1469  | 330 | 255 | 225    |
| RL 64-40-1 | 919    | 575 | 1494  | 360 | 285 | 258    |
| RL 64-40   | 919    | 575 | 1494  | 360 | 285 | 258    |
| RL 64-50-2 | 1001   | 650 | 1651  | 400 | 310 | 319    |
| RL 64-50-1 | 1001   | 650 | 1651  | 400 | 310 | 320    |
| RL 64-50   | 1001   | 650 | 1651  | 400 | 310 | 320    |
| RL 64-60-2 | 1084   | 650 | 1734  | 400 | 310 | 325    |
| RL 64-60-1 | 1084   | 650 | 1734  | 400 | 310 | 349    |
| RL 64-60   | 1084   | 650 | 1734  | 400 | 310 | 349    |
| RL 64-70-2 | 1166   | 650 | 1816  | 400 | 310 | 353    |
| RL 64-70-1 | 1166   | 650 | 1816  | 400 | 310 | 353    |
| RL 64-70   | 1166   | 685 | 1851  | 460 | 340 | 420    |
| RL 64-80-2 | 1248   | 685 | 1933  | 460 | 340 | 424    |
| RL 64-80-1 | 1248   | 685 | 1933  | 460 | 340 | 424    |

## 性能表

| 型号         | 配用电机<br>(kW) | Q<br>(m <sup>3</sup> /h) | H (m) |     |     |     |     |     |     |  |
|------------|--------------|--------------------------|-------|-----|-----|-----|-----|-----|-----|--|
|            |              |                          | 30    | 40  | 50  | 60  | 64  | 70  | 80  |  |
| RL 64-10-1 | 4.0          | H (m)                    | 19    | 18  | 16  | 14  | 13  | 11  | 8   |  |
| RL 64-10   | 5.5          |                          | 27    | 25  | 23  | 21  | 20  | 18  | 15  |  |
| RL 64-20-2 | 7.5          |                          | 39    | 36  | 33  | 29  | 27  | 23  | 17  |  |
| RL 64-20-1 | 11           |                          | 46    | 44  | 40  | 36  | 34  | 30  | 24  |  |
| RL 64-20   | 11           |                          | 53    | 51  | 47  | 43  | 41  | 37  | 30  |  |
| RL 64-30-2 | 15           |                          | 66    | 62  | 56  | 50  | 47  | 41  | 32  |  |
| RL 64-30-1 | 15           |                          | 73    | 69  | 63  | 57  | 54  | 48  | 39  |  |
| RL 64-30   | 18.5         |                          | 80    | 76  | 70  | 64  | 61  | 55  | 46  |  |
| RL 64-40-2 | 18.5         |                          | 92    | 87  | 80  | 71  | 67  | 60  | 47  |  |
| RL 64-40-1 | 22           |                          | 100   | 94  | 87  | 78  | 74  | 67  | 54  |  |
| RL 64-40   | 22           |                          | 107   | 101 | 94  | 85  | 81  | 74  | 61  |  |
| RL 64-50-2 | 30           |                          | 121   | 114 | 105 | 95  | 89  | 80  | 64  |  |
| RL 64-50-1 | 30           |                          | 128   | 121 | 112 | 102 | 96  | 87  | 71  |  |
| RL 64-50   | 30           |                          | 136   | 129 | 119 | 109 | 103 | 94  | 78  |  |
| RL 64-60-2 | 30           |                          | 150   | 142 | 131 | 118 | 111 | 101 | 81  |  |
| RL 64-60-1 | 37           |                          | 157   | 149 | 138 | 125 | 118 | 108 | 88  |  |
| RL 64-60   | 37           |                          | 164   | 156 | 145 | 132 | 125 | 115 | 95  |  |
| RL 64-70-2 | 37           |                          | 179   | 169 | 156 | 141 | 133 | 121 | 99  |  |
| RL 64-70-1 | 37           |                          | 186   | 176 | 163 | 148 | 141 | 128 | 106 |  |
| RL 64-70   | 45           |                          | 193   | 183 | 170 | 155 | 148 | 135 | 112 |  |
| RL 64-80-2 | 45           | 207                      | 196   | 182 | 164 | 156 | 142 | 116 |     |  |
| RL 64-80-1 | 45           | 215                      | 203   | 189 | 171 | 163 | 149 | 123 |     |  |

隔爆电机外形尺寸有所变动, 详情请咨询本公司; SDL64系列可安客户要求供应PN25-40/DN100标准法兰。

## 性能曲线

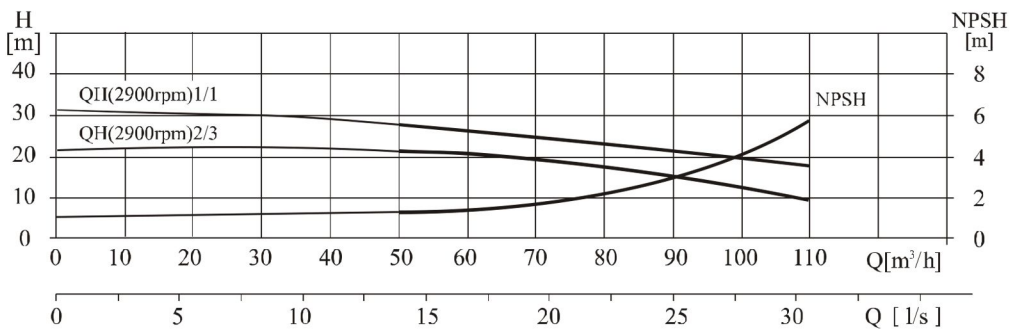
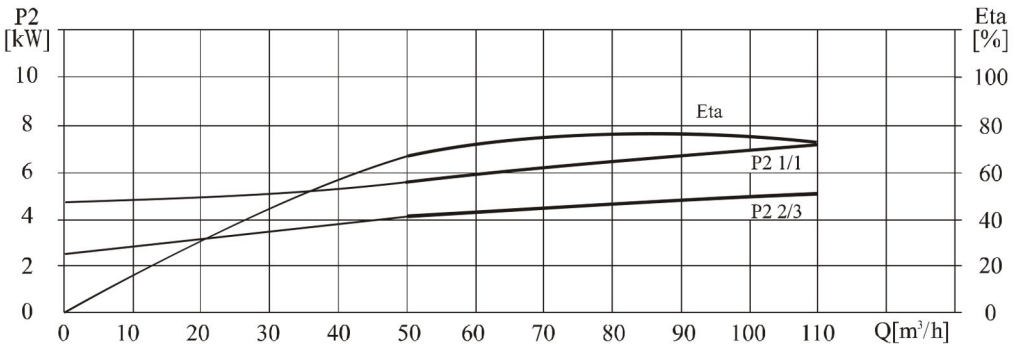
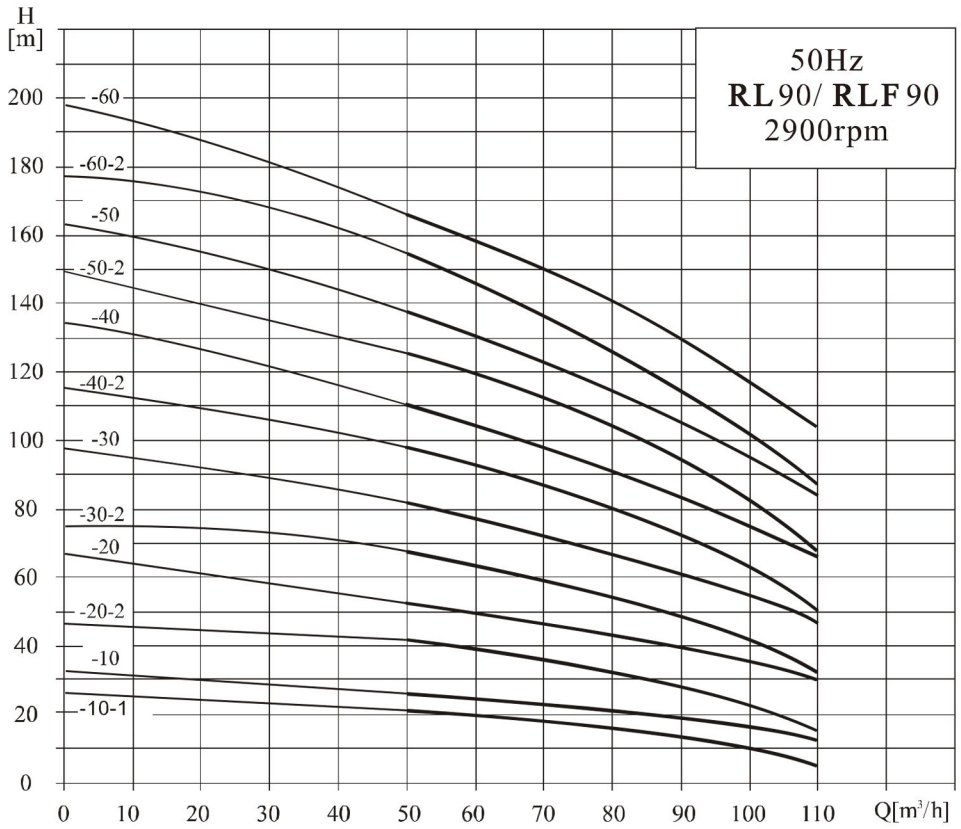



## 安装图

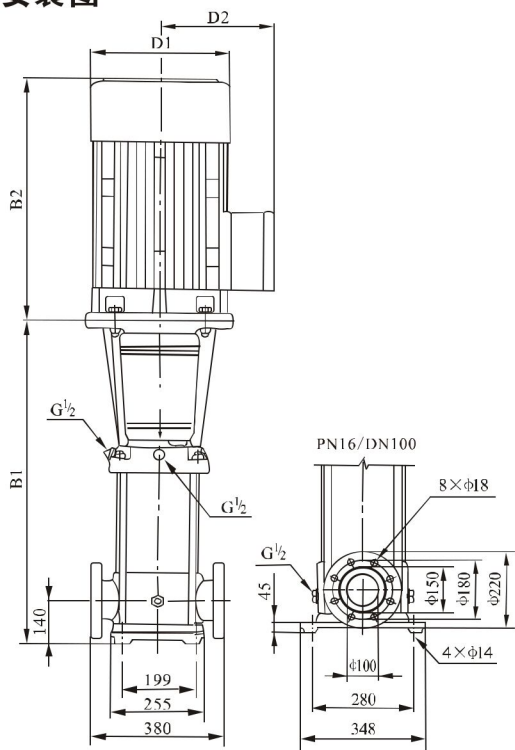

## 尺寸和重量

| 型号         | 尺寸(mm) |     |       |     |     | 重量(kg) |
|------------|--------|-----|-------|-----|-----|--------|
|            | B1     | B2  | B1+B2 | D1  | D2  |        |
| RL 90-10-1 | 571    | 390 | 961   | 260 | 208 | 105    |
| RL 90-10   | 571    | 390 | 961   | 260 | 208 | 110    |
| RL 90-20-2 | 773    | 500 | 1273  | 330 | 255 | 181    |
| RL 90-20   | 773    | 500 | 1273  | 330 | 255 | 192    |
| RL 90-30-2 | 865    | 550 | 1415  | 330 | 255 | 215    |
| RL 90-30   | 865    | 575 | 1440  | 360 | 285 | 252    |
| RL 90-40-2 | 957    | 650 | 1607  | 400 | 310 | 312    |
| RL 90-40   | 957    | 650 | 1607  | 400 | 310 | 312    |
| RL 90-50-2 | 1049   | 650 | 1699  | 400 | 310 | 336    |
| RL 90-50   | 1049   | 650 | 1699  | 400 | 310 | 336    |
| RL 90-60-2 | 1141   | 685 | 1826  | 460 | 340 | 407    |
| RL 90-60   | 1141   | 685 | 1826  | 460 | 340 | 407    |

## 性能表

| 型号         | 配用电机<br>(kW) | Q<br>(m <sup>3</sup> /h) | H<br>(m) |     |     |     |     |     |     |
|------------|--------------|--------------------------|----------|-----|-----|-----|-----|-----|-----|
|            |              |                          | 50       | 60  | 70  | 80  | 90  | 100 | 110 |
| RL 90-10-1 | 5.5          | H                        | 22       | 19  | 17  | 16  | 13  | 10  | 6   |
| RL 90-10   | 7.5          |                          | 25       | 24  | 22  | 21  | 19  | 16  | 12  |
| RL 90-20-2 | 11           |                          | 41       | 39  | 36  | 32  | 28  | 22  | 15  |
| RL 90-20   | 15           |                          | 53       | 50  | 47  | 44  | 40  | 36  | 30  |
| RL 90-30-2 | 18.5         |                          | 68       | 65  | 60  | 55  | 49  | 41  | 32  |
| RL 90-30   | 22           |                          | 81       | 77  | 72  | 67  | 62  | 55  | 48  |
| RL 90-40-2 | 30           |                          | 98       | 93  | 87  | 80  | 72  | 62  | 50  |
| RL 90-40   | 30           |                          | 110      | 105 | 100 | 92  | 84  | 76  | 66  |
| RL 90-50-2 | 37           |                          | 126      | 120 | 113 | 104 | 93  | 81  | 68  |
| RL 90-50   | 37           |                          | 139      | 131 | 124 | 115 | 106 | 94  | 83  |
| RL 90-60-2 | 45           |                          | 155      | 148 | 139 | 129 | 117 | 102 | 86  |
| RL 90-60   | 45           |                          | 168      | 160 | 150 | 141 | 130 | 117 | 103 |

隔爆电机外形尺寸有所变动, 详情请咨询本公司; SDL90系列可安客户要求供应PN25-40/DN100标准法兰。

## 性能曲线

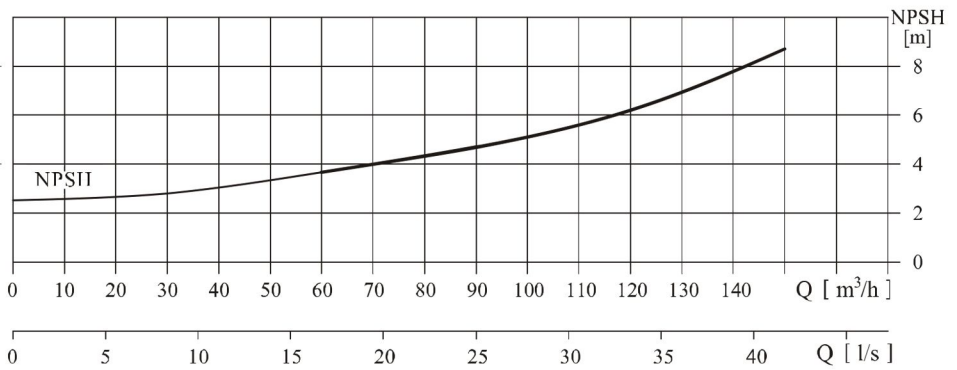
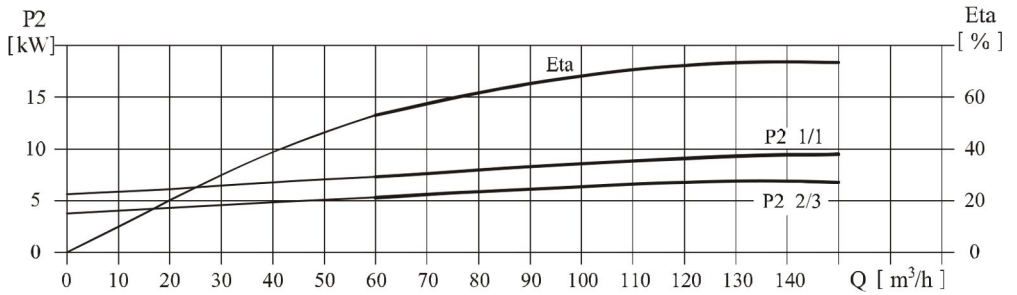
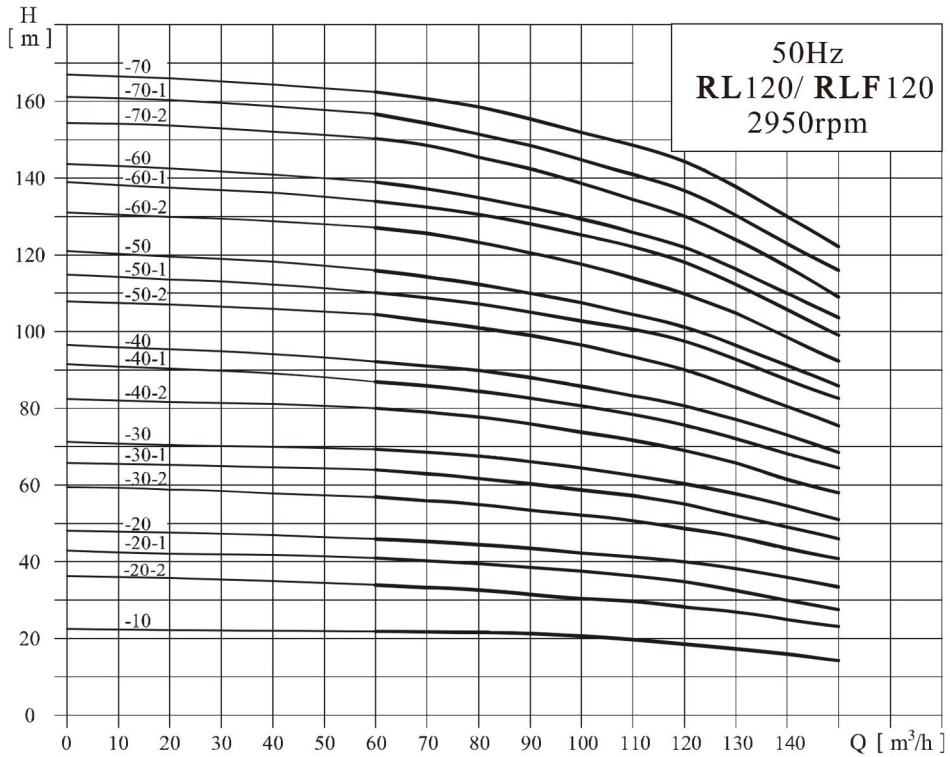

## 安装图

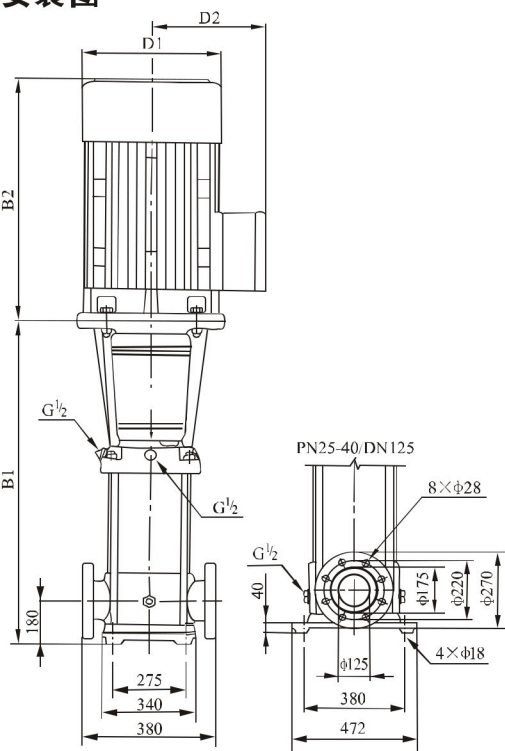

## 尺寸和重量

| 型号          | 尺寸(mm) |     |       |     |     | 重量(kg) |
|-------------|--------|-----|-------|-----|-----|--------|
|             | B1     | B2  | B1+B2 | D1  | D2  |        |
| RL 120-10   | 840    | 500 | 1340  | 330 | 255 | 230    |
| RL 120-20-2 | 1000   | 500 | 1500  | 330 | 255 | 245    |
| RL 120-20-1 | 1000   | 550 | 1550  | 330 | 255 | 250    |
| RL 120-20   | 1000   | 575 | 1575  | 360 | 285 | 285    |
| RL 120-30-2 | 1160   | 650 | 1810  | 400 | 310 | 359    |
| RL 120-30-1 | 1160   | 650 | 1810  | 400 | 310 | 360    |
| RL 120-30   | 1160   | 650 | 1810  | 400 | 310 | 360    |
| RL 120-40-2 | 1320   | 650 | 1970  | 400 | 310 | 400    |
| RL 120-40-1 | 1320   | 650 | 1970  | 400 | 310 | 400    |
| RL 120-40   | 1320   | 685 | 2005  | 460 | 340 | 460    |
| RL 120-50-2 | 1480   | 685 | 2165  | 460 | 340 | 470    |
| RL 120-50-1 | 1480   | 685 | 2165  | 460 | 340 | 470    |
| RL 120-50   | 1510   | 760 | 2270  | 540 | 370 | 575    |
| RL 120-60-2 | 1670   | 760 | 2430  | 540 | 370 | 585    |
| RL 120-60-1 | 1670   | 760 | 2430  | 540 | 370 | 585    |
| RL 120-60   | 1830   | 845 | 2515  | 580 | 410 | 705    |
| RL 120-70-2 | 1830   | 845 | 2675  | 580 | 410 | 715    |
| RL 120-70-1 | 1830   | 845 | 2675  | 580 | 410 | 715    |
| RL 120-70   | 1830   | 845 | 2675  | 580 | 410 | 715    |

## 性能表

| 型号          | 配用电机<br>(kW) | Q<br>(m <sup>3</sup> /h) | H (m) |       |       |       |       |       |       |       |       |       |
|-------------|--------------|--------------------------|-------|-------|-------|-------|-------|-------|-------|-------|-------|-------|
|             |              |                          | 60    | 70    | 80    | 90    | 100   | 110   | 120   | 130   | 140   | 150   |
| RL 120-10   | 11           | H (m)                    | 22    | 21.8  | 21.6  | 21    | 20.5  | 19.5  | 18.5  | 17    | 16    | 15    |
| RL 120-20-2 | 15           |                          | 34    | 33.6  | 33    | 31    | 30.2  | 30    | 28.5  | 27    | 25    | 24    |
| RL 120-20-1 | 18.5         |                          | 41    | 40    | 39.5  | 38.5  | 37    | 36.5  | 34.5  | 32.5  | 30    | 27.5  |
| RL 120-20   | 22           |                          | 46    | 45    | 44.5  | 43.5  | 42.4  | 41    | 40    | 38    | 36    | 33.5  |
| RL 120-30-2 | 30           |                          | 57    | 56    | 55    | 53.5  | 52    | 51    | 49    | 46.5  | 43.5  | 41    |
| RL 120-30-1 | 30           |                          | 64    | 63    | 62    | 60    | 58.5  | 57.5  | 55.5  | 52    | 49    | 46    |
| RL 120-30   | 30           |                          | 69.5  | 68.5  | 67.5  | 66    | 64.4  | 62.5  | 61    | 57.5  | 54.5  | 51    |
| RL 120-40-2 | 37           |                          | 80.5  | 79    | 78    | 76    | 73.5  | 72    | 69    | 66    | 61.5  | 58    |
| RL 120-40-1 | 37           |                          | 87    | 86    | 84.5  | 82    | 80    | 78    | 76    | 72    | 68    | 64.5  |
| RL 120-40   | 45           |                          | 92.5  | 91    | 90    | 88    | 85.5  | 83    | 81    | 77    | 73    | 68.5  |
| RL 120-50-2 | 45           |                          | 104.5 | 103   | 101   | 99    | 96    | 93    | 90    | 85.5  | 80.5  | 75.5  |
| RL 120-50-1 | 45           |                          | 110.5 | 109   | 107.5 | 105   | 102   | 100   | 97    | 92    | 86.5  | 83    |
| RL 120-50   | 55           |                          | 115.5 | 114   | 113   | 110   | 107.5 | 104.5 | 101.5 | 96    | 91    | 86    |
| RL 120-60-2 | 55           |                          | 128   | 125.5 | 123   | 121   | 117.3 | 113.5 | 110   | 104.5 | 98.5  | 92.5  |
| RL 120-60-1 | 55           |                          | 134   | 132   | 130.5 | 127   | 124   | 121   | 118   | 111   | 105   | 100   |
| RL 120-60   | 75           |                          | 139   | 137   | 135   | 132   | 128.8 | 126   | 123   | 116   | 110   | 104   |
| RL 120-70-2 | 75           |                          | 151   | 148   | 145.5 | 143   | 138.6 | 134   | 130   | 123.5 | 116.5 | 109   |
| RL 120-70-1 | 75           |                          | 156.5 | 154   | 152   | 148.5 | 144.5 | 141   | 137.5 | 130   | 123   | 116.5 |
| RL 120-70   | 75           |                          | 162.5 | 160.5 | 158.5 | 155   | 151   | 148   | 145   | 137   | 129   | 123   |

隔爆电机外形尺寸有所变动, 详情请咨询本公司。

## 性能曲线

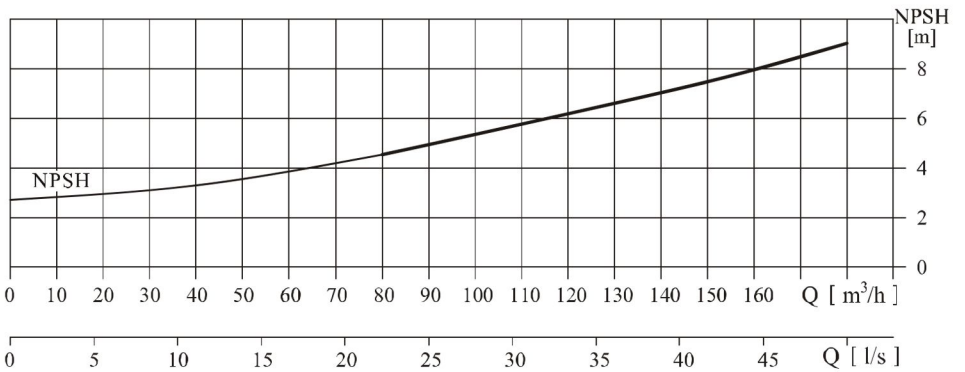
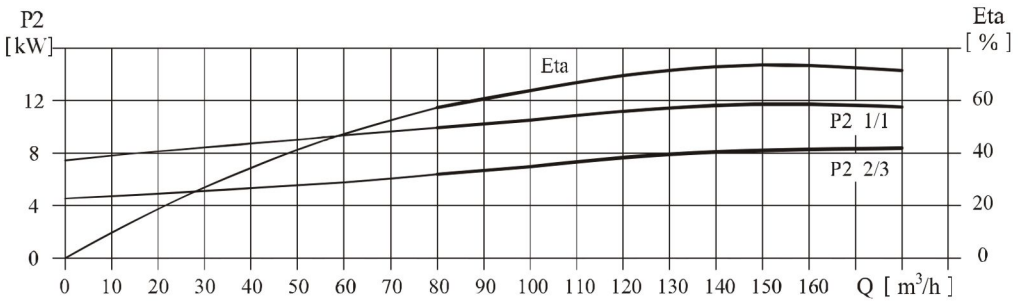
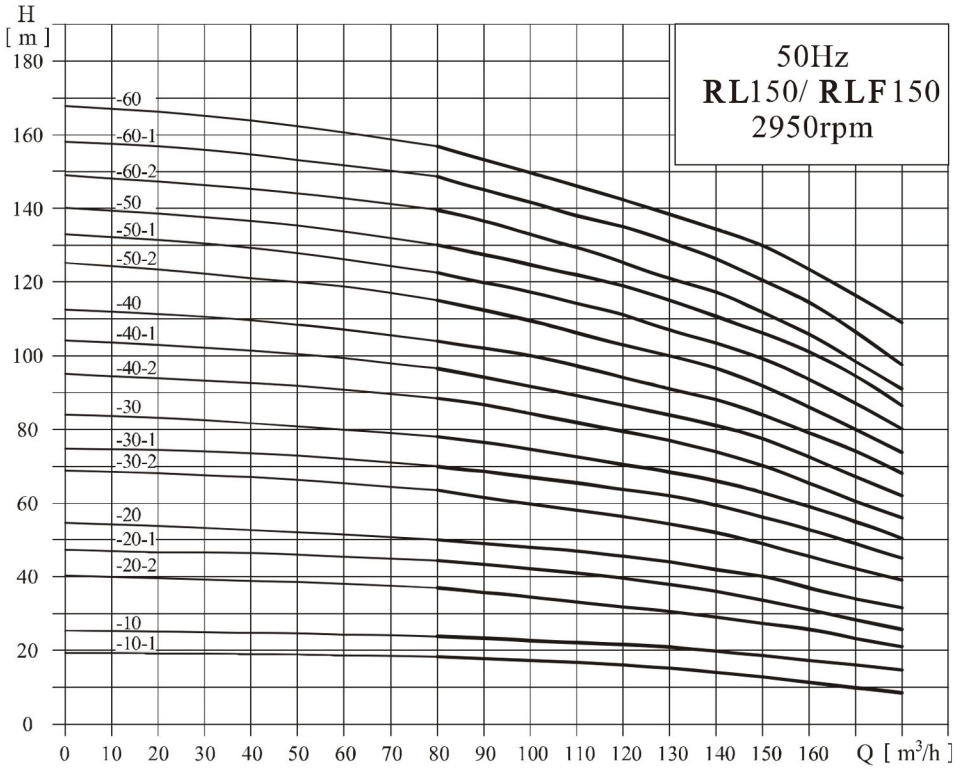

## 安装图

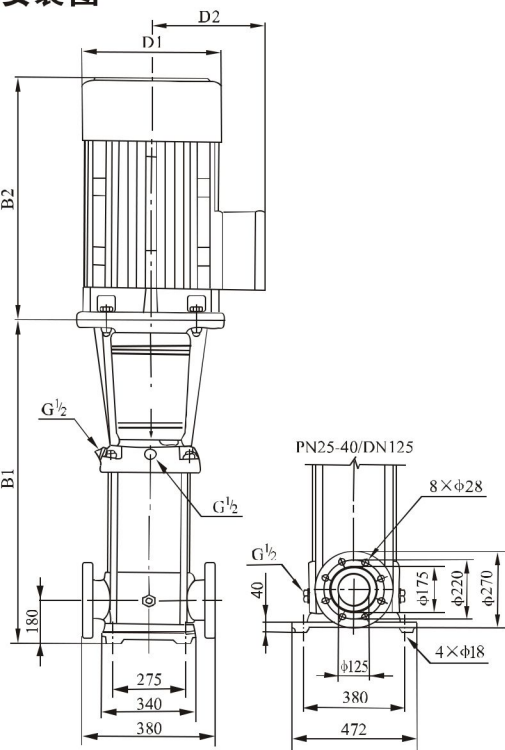

## 尺寸和重量

| 型号         | 尺寸(mm) |     |       |     |     | 重量(kg) |
|------------|--------|-----|-------|-----|-----|--------|
|            | B1     | B2  | B1+B2 | D1  | D2  |        |
| RL150-10-1 | 840    | 500 | 1340  | 330 | 255 | 230    |
| RL150-10   | 840    | 500 | 1340  | 330 | 255 | 235    |
| RL150-20-2 | 1000   | 550 | 1550  | 330 | 255 | 250    |
| RL150-20-1 | 1000   | 575 | 1575  | 360 | 285 | 295    |
| RL150-20   | 1000   | 650 | 1650  | 400 | 310 | 350    |
| RL150-30-2 | 1160   | 650 | 1810  | 400 | 310 | 360    |
| RL150-30-1 | 1160   | 650 | 1810  | 400 | 310 | 360    |
| RL150-30   | 1160   | 650 | 1810  | 400 | 310 | 385    |
| RL150-40-2 | 1320   | 685 | 2005  | 460 | 340 | 460    |
| RL150-40-1 | 1320   | 685 | 2005  | 460 | 340 | 460    |
| RL150-40   | 1350   | 760 | 2110  | 540 | 370 | 560    |
| RL150-50-2 | 1510   | 760 | 2270  | 540 | 370 | 570    |
| RL150-50-1 | 1510   | 845 | 2355  | 580 | 410 | 690    |
| RL150-50   | 1510   | 845 | 2355  | 580 | 410 | 690    |
| RL150-60-2 | 1670   | 845 | 2515  | 580 | 410 | 700    |
| RL150-60-1 | 1670   | 845 | 2515  | 580 | 410 | 700    |
| RL150-60   | 1670   | 845 | 2515  | 580 | 410 | 700    |

## 性能表

| 型号         | 配用电机<br>(kW) | Q<br>(m <sup>3</sup> /h) | H (m) |       |       |       |       |       |       |       |       |       |      |  |
|------------|--------------|--------------------------|-------|-------|-------|-------|-------|-------|-------|-------|-------|-------|------|--|
|            |              |                          | 80    | 90    | 100   | 110   | 120   | 130   | 140   | 150   | 160   | 170   | 180  |  |
| RL150-10-1 | 11           | H (m)                    | 18.3  | 17.8  | 17.3  | 17    | 16    | 15    | 14    | 12.5  | 11    | 10    | 8.5  |  |
| RL150-10   | 15           |                          | 24    | 23    | 22.5  | 22    | 21.5  | 20.5  | 20    | 18.5  | 17    | 16    | 15   |  |
| RL150-20-2 | 18.5         |                          | 37    | 35.5  | 34    | 33    | 32    | 31    | 29    | 27.5  | 26    | 23    | 21   |  |
| RL150-20-1 | 22           |                          | 44.3  | 43    | 42    | 40    | 39    | 38.5  | 37.5  | 35    | 33    | 30    | 27   |  |
| RL150-20   | 30           |                          | 50    | 49    | 48    | 47    | 45.5  | 44    | 42    | 40    | 37    | 34    | 32   |  |
| RL150-30-2 | 30           |                          | 63.5  | 61    | 59    | 57.5  | 56    | 54.5  | 53    | 49    | 45.5  | 42    | 39   |  |
| RL150-30-1 | 37           |                          | 70    | 68    | 67    | 65    | 63    | 62    | 60    | 56    | 53    | 49    | 45   |  |
| RL150-30   | 37           |                          | 78    | 76.5  | 75    | 73    | 70.5  | 68    | 66    | 63    | 59    | 55    | 50.5 |  |
| RL150-40-2 | 45           |                          | 89    | 87    | 84    | 81.5  | 79    | 77    | 74.5  | 70.5  | 65.5  | 60    | 56   |  |
| RL150-40-1 | 45           |                          | 96.5  | 94    | 91.5  | 89    | 86.5  | 84    | 81.5  | 77    | 72.5  | 67    | 62   |  |
| RL150-40   | 55           |                          | 104   | 102   | 100   | 97    | 95    | 91    | 88    | 84    | 79.5  | 74    | 68   |  |
| RL150-50-2 | 55           |                          | 115.5 | 112   | 109   | 106   | 102.5 | 100   | 97    | 92    | 86    | 79    | 73.5 |  |
| RL150-50-1 | 75           |                          | 122.5 | 119.5 | 117   | 113.5 | 111.5 | 107.5 | 104.5 | 99    | 93.5  | 87    | 80   |  |
| RL150-50   | 75           |                          | 130   | 127.5 | 125   | 121   | 119   | 115   | 111.5 | 106.5 | 101   | 94.5  | 86.5 |  |
| RL150-60-2 | 75           |                          | 140   | 137   | 133   | 130   | 126   | 121   | 118   | 112   | 106   | 98    | 91   |  |
| RL150-60-1 | 75           |                          | 148.5 | 145   | 141.7 | 137.5 | 135   | 131   | 127   | 120.5 | 114.5 | 106.5 | 97.5 |  |
| RL150-60   | 75           |                          | 157   | 153   | 149   | 145   | 142   | 139.5 | 137   | 130   | 123.5 | 116   | 109  |  |

隔爆电机外形尺寸有所变动，详情请咨询本公司。

## 性能曲线

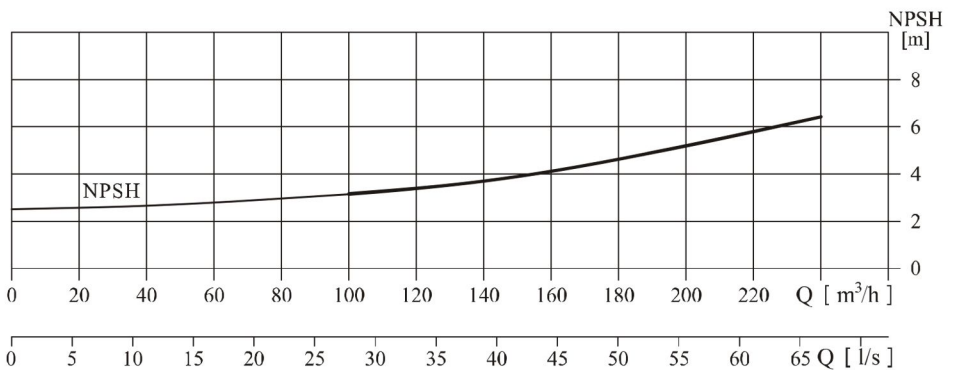
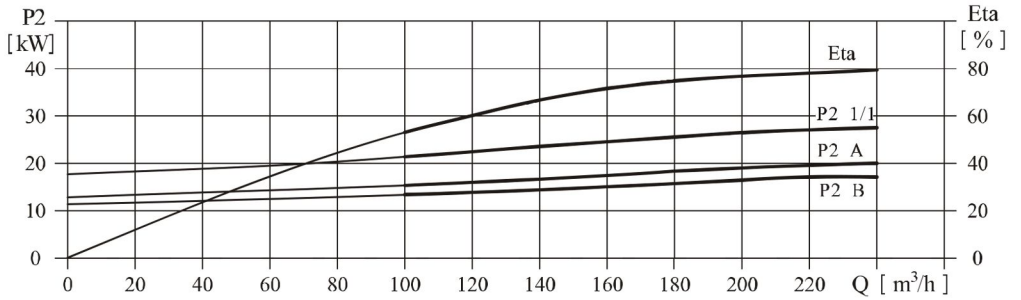
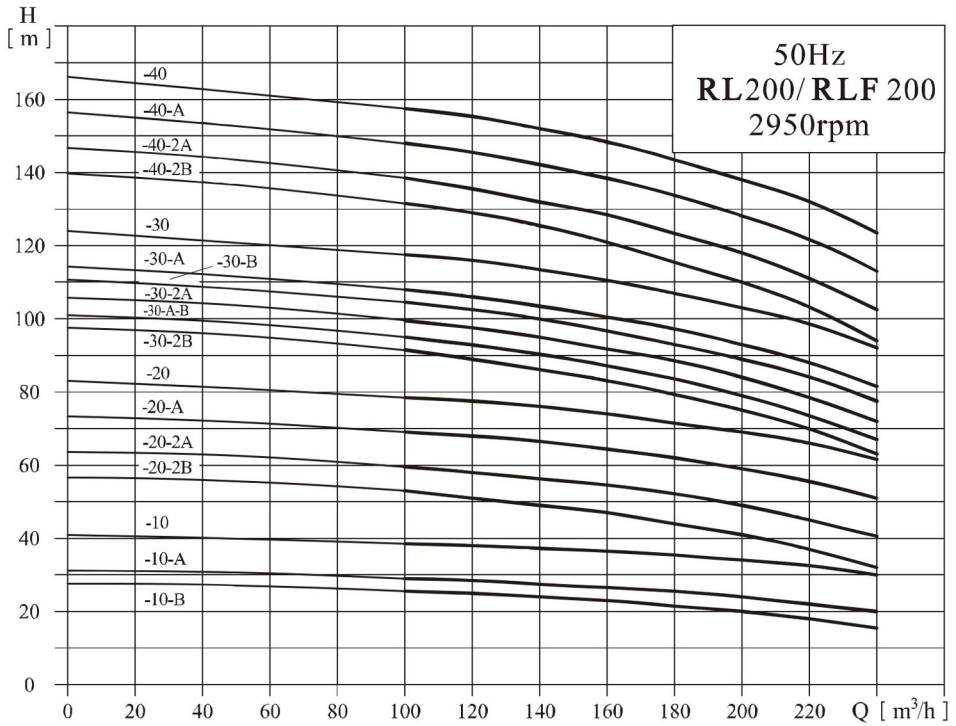

## 安装图

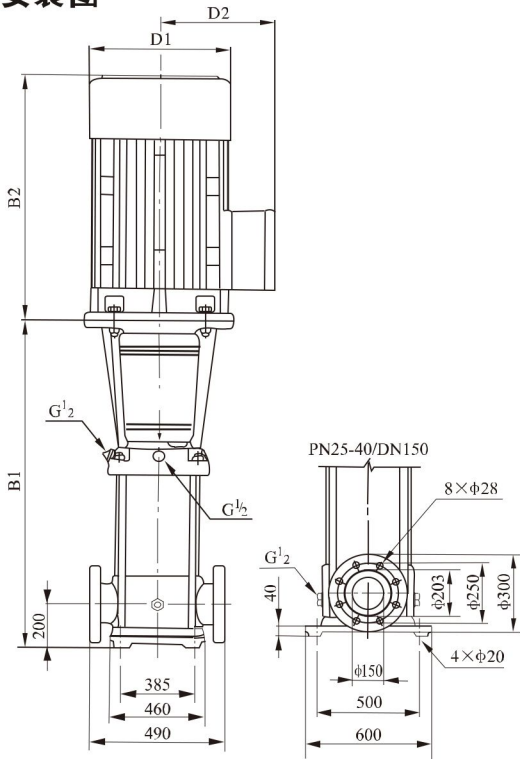

## 尺寸和重量

| 型号           | 尺寸(mm) |      |       |     |     | 重量(kg) |
|--------------|--------|------|-------|-----|-----|--------|
|              | B1     | B2   | B1+B2 | D1  | D2  |        |
| RL200-10-B   | 907    | 550  | 1457  | 330 | 255 | 311    |
| RL200-10-A   | 907    | 575  | 1482  | 360 | 285 | 347    |
| RL200-10     | 907    | 650  | 1557  | 400 | 310 | 403    |
| RL200-20-2B  | 1101   | 650  | 1751  | 400 | 310 | 447    |
| RL200-20-2A  | 1101   | 685  | 1786  | 460 | 340 | 504    |
| RL200-20-A   | 1131   | 760  | 1891  | 540 | 370 | 595    |
| RL200-20     | 1131   | 760  | 1891  | 540 | 370 | 595    |
| RL200-30-2B  | 1325   | 845  | 2170  | 580 | 410 | 748    |
| RL200-30-A-B | 1325   | 845  | 2170  | 580 | 410 | 748    |
| RL200-30-2A  | 1325   | 845  | 2170  | 580 | 410 | 748    |
| RL200-30-B   | 1325   | 845  | 2170  | 580 | 410 | 748    |
| RL200-30-A   | 1325   | 845  | 2170  | 580 | 410 | 748    |
| RL200-30     | 1325   | 895  | 2220  | 580 | 410 | 817    |
| RL200-40-2B  | 1519   | 895  | 2414  | 580 | 410 | 830    |
| RL200-40-2A  | 1519   | 1140 | 2659  | 645 | 550 | 1180   |
| RL200-40-A   | 1519   | 1140 | 2659  | 645 | 550 | 1180   |
| RL200-40     | 1519   | 1140 | 2659  | 645 | 550 | 1180   |

## 性能表

| 型号           | 配用电机<br>(kW) | Q<br>(m <sup>3</sup> h) | H (m) |       |       |       |       |     |       |       |
|--------------|--------------|-------------------------|-------|-------|-------|-------|-------|-----|-------|-------|
|              |              |                         | 100   | 120   | 140   | 160   | 180   | 200 | 220   | 240   |
| RL200-10-B   | 18.5         | H (m)                   | 25.5  | 25    | 24    | 23    | 21.5  | 20  | 18    | 15.5  |
| RL200-10-A   | 22           |                         | 29    | 28.5  | 27.5  | 26.5  | 25.5  | 24  | 22    | 20    |
| RL200-10     | 30           |                         | 38.5  | 38    | 37.5  | 36.5  | 35    | 34  | 32.5  | 30    |
| RL200-20-2B  | 37           |                         | 53    | 51    | 49    | 47    | 44    | 41  | 37    | 32    |
| RL200-20-2A  | 45           |                         | 59.5  | 58    | 56    | 54    | 52.5  | 49  | 44.5  | 40.5  |
| RL200-20-A   | 55           |                         | 69    | 68    | 66    | 64    | 62    | 59  | 55.5  | 51    |
| RL200-20     | 55           |                         | 78.5  | 77.5  | 76    | 74    | 71.5  | 69  | 66    | 61.5  |
| RL200-30-2B  | 75           |                         | 91.5  | 89    | 86.5  | 83.5  | 79    | 75  | 70    | 63    |
| RL200-30-A-B | 75           |                         | 95    | 93    | 90    | 87    | 83.5  | 79  | 73.5  | 67    |
| RL200-30-2A  | 75           |                         | 99.5  | 97.5  | 94.5  | 91.5  | 89    | 84  | 78.5  | 72    |
| RL200-30-B   | 75           |                         | 104.5 | 102.5 | 100   | 97    | 93    | 89  | 84.5  | 77.5  |
| RL200-30-A   | 75           |                         | 108   | 106   | 103.5 | 100.5 | 97.5  | 93  | 88    | 81.5  |
| RL200-30     | 90           |                         | 117.5 | 116   | 113.5 | 110.5 | 107   | 103 | 99    | 92    |
| RL200-40-2B  | 90           |                         | 131.5 | 129   | 125.5 | 121   | 115.5 | 110 | 103.5 | 94    |
| RL200-40-2A  | 110          |                         | 138.5 | 136   | 132   | 128   | 124   | 118 | 111   | 102.5 |
| RL200-40-A   | 110          |                         | 148   | 145.5 | 142.5 | 138   | 134   | 128 | 122   | 113   |
| RL200-40     | 110          |                         | 157.5 | 155.5 | 152.5 | 148   | 143.5 | 138 | 132.5 | 123.5 |

隔爆电机外形尺寸有所变动，详情请咨询本公司。

## RLF + RLH高压型泵

泵的高压力在很多应用中是至关重要的，特别是水处理，过滤和净化。为提供最佳的解决方案，任原设计的RLF+RLH泵可承受很高的压力。

### 当需要高压力时

RLF+RLH高压型泵提供独特的很紧凑的高转速泵，其可提供极高的压力，对需要大流量的场合可采用多台串联。这种方案使您可采用标准泵作为高压泵。这类泵可输送不同的介质，从饮用水到腐蚀性的工业液体，而且可在大的温度范围下运行。

### RLF+RLH高压型泵有何特别

通常多级泵可产生高压力，液体从泵的底部吸入，泵的最高压力点位于泵的上部，对压力最敏感的部件—机械密封也位于泵的上部。对标准泵而言，轴封会决定泵的承压极限。

### 吸入端上置方案

对RLF+RLH高压型泵在其内部采用吸入端上置方案。这样使泵的最高压力点位于泵下面坚固的基座处，远离易损的轴封，降低轴封处的压力还可带来减小筒体密封处的好处。



### 技术参数

最大压力:48bar

最大液体温度:105°C

最大环境温度:40°C

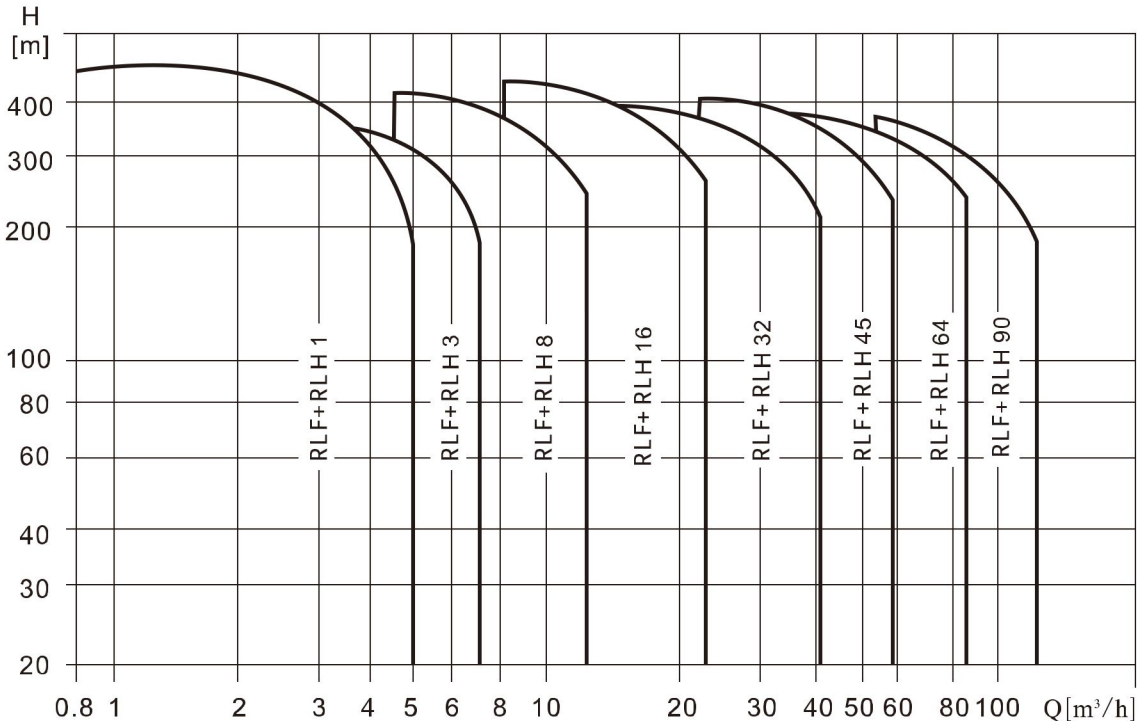



RenYuan<sup>®</sup>  
任元

# 有任原的地方 就有水



**任原泵业(杭州)有限公司**

RENYUAN PUMPS HANG ZHOU CO.,LTD

办公地址(Add): 中国浙江杭州余杭区南苑街道  
理想银泰城10幢1单元3801室

电话(Tel): 0571-85028785

传真(Fax): 0571-86598195

网址: [Http://WWW.renyuan pumps.xin](http://WWW.renyuan pumps.xin)

160404

数据仅供参考: 如有修改, 恕不通知。

版权所有, 盗版必究!